



# **Housing** Executive

**NIHE  
STANDARD DETAILS**

**March 2017 - Amendment 1 (April 2017)**

**Director of Landlord Services  
The Housing Executive  
2 Adelaide Street  
Belfast BT2 8PB**

## **ACKNOWLEDGEMENTS**

Grateful acknowledgement is made to the Building Project Information Committee for the use of the Co-ordinated Project Information (CPI) Logo.

The Housing Executive's Standard Specification is based on and adapted from the National Building Specification and grateful acknowledgement of this fact is made to National Building Specification Ltd.

## **COPYRIGHT**

**© NIHE 2017**

NIHE Staff, Consultants and Contractors may copy or reproduce any part or parts of the NIHE Standard Documentation for Construction Contracts, but only for use solely in connection with NIHE construction contracts or schemes and no others.

Copyright in respect of all other uses of the Standard Documentation for Construction Contracts is strictly reserved to the NIHE.

For the avoidance of doubt, the Standard Documentation for Construction Contracts is primarily designed for use only in construction contracts or schemes to which the NIHE is a party or which are being provided for and on behalf of NIHE by its Consultants or Contractors. NIHE does not permit or authorise the usage of any part or parts of its Standard Documentation for Construction Contracts in any non NIHE contract or scheme and it does not accept any liability whatsoever (excepting personal injuries or death) for any loss or damage howsoever caused or sustained by any person who uses its Standard Documentation for Construction Contracts without its written permission or consent.

### Associated Standard Details Index

		10	11	12	13	14	15	16
1	<b>Substructure &amp; Ground Floors</b>	Foundations	Ground Floors	Domestic Drainage				
2	<b>Walls &amp; First Floors</b>		Thresholds, Reveals, Cills & Heads	First Floors		Anchor Straps		
3	<b>Chimneys &amp; Flues</b>			Flues & Stacks				
4	<b>Roof Structure</b>	Ridge Details	Flashings	Eaves Details				
5	<b>Openings</b>	Windows	Doors		Ventilators			
6	<b>Internal Elements</b>		Stairs	Hotpress, Wardrobe Bath Seats	Meter Cupboards			
7	<b>Fittings</b>	Kitchen Units & Worktops		Shower Enclosure				
8	<b>External &amp; Public Works</b>	Fencing & Gates	Ramps & Furniture	Landscape	Road, Footpaths Shared Surfaces	Storm & Foul Drainage		
9	<b>Services</b>	Mechanical						Electrical
10	<b>APD Toolkit</b>	Level 1 AmbulantUser	Level 2 Independent Wheelchair User	Level 3 Assisted Wheelchair User				

\* This NIHE produced detail has been examined by The Building Control N.I. Standards Panel and has been considered reasonable in its interpretation of the relevant requirements of the Building Regulation NI 2012. There is no legal obligation for any Building Control department to adopt this recommendation & it is subject to revision in the event of changes to the legislation or other mitigating circumstances.

NB: See Building Control Technical Booklet N 2012  
 - Drainage: Item 3.9 Special Protection - Settlement;  
 and Diagram 3.7 - Pipe runs near building.

Where X (distance between foundation and trench) is less than 1m, fill the trench with concrete to the level of the underside of the foundation.

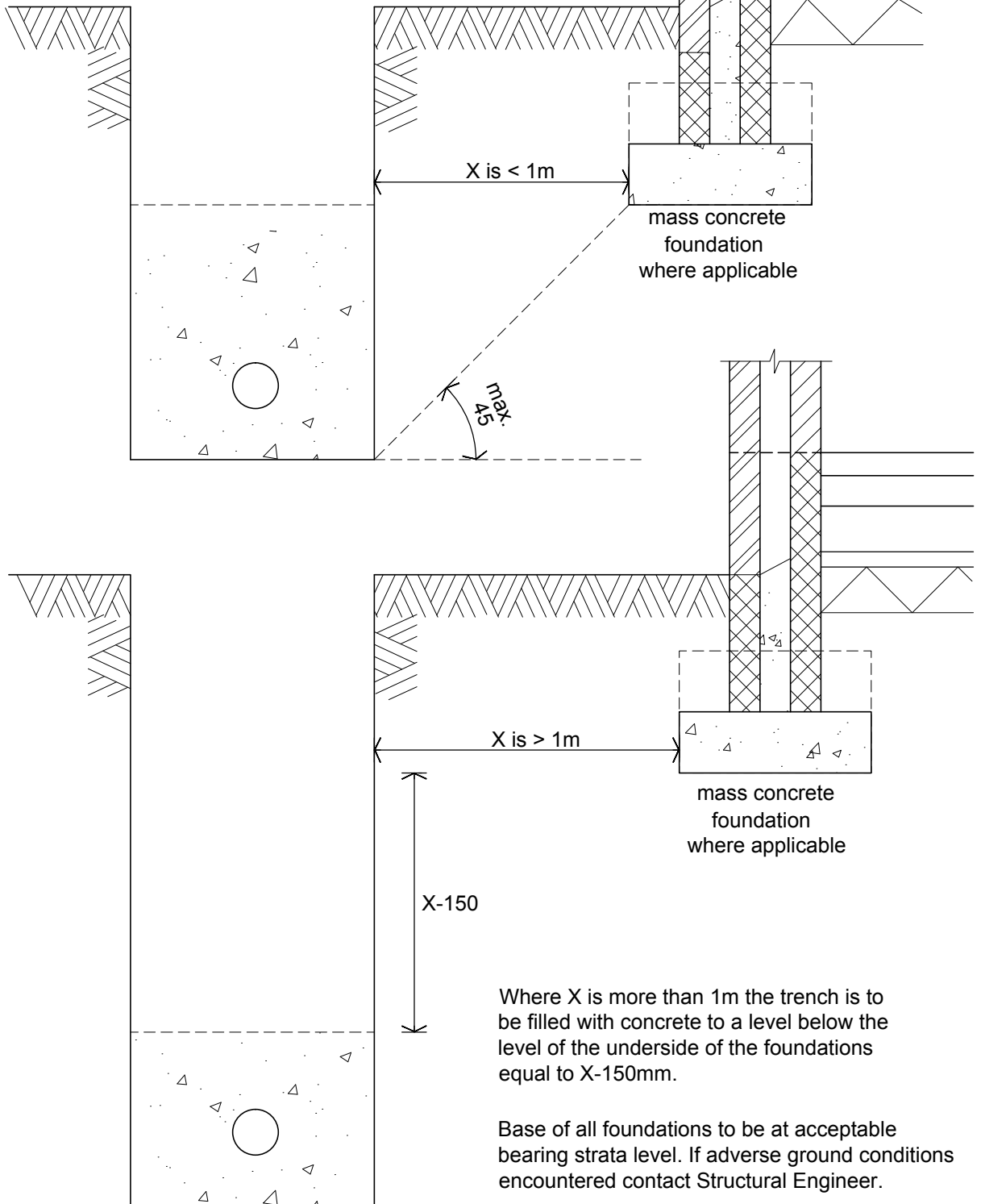

SPECIFICATION REFERENCE: R12/380

© NIHE 2017  
 DRAWINGS NOT TO BE SCALED DUE TO PRINTING DISTORTION



TITLE  
 POSITION OF EXCAVATION IN RELATION TO FOUNDATIONS

DRAWN BY LM/CB	SCALE 1:20	DATE Jan 91
DRAWING NO.	A(01.10)01	
REV NO. & DATE	(2) 08/12	
REV NOTE: Updated to Building Regs 2012		



\* This NIHE produced detail has been examined by The Building Control N.I. Standards Panel and has been considered reasonable in its interpretation of the relevant requirements of the Building Regulation NI 2012. There is no legal obligation for any Building Control department to adopt this recommendation & it is subject to revision in the event of changes to the legislation or other mitigating circumstances.

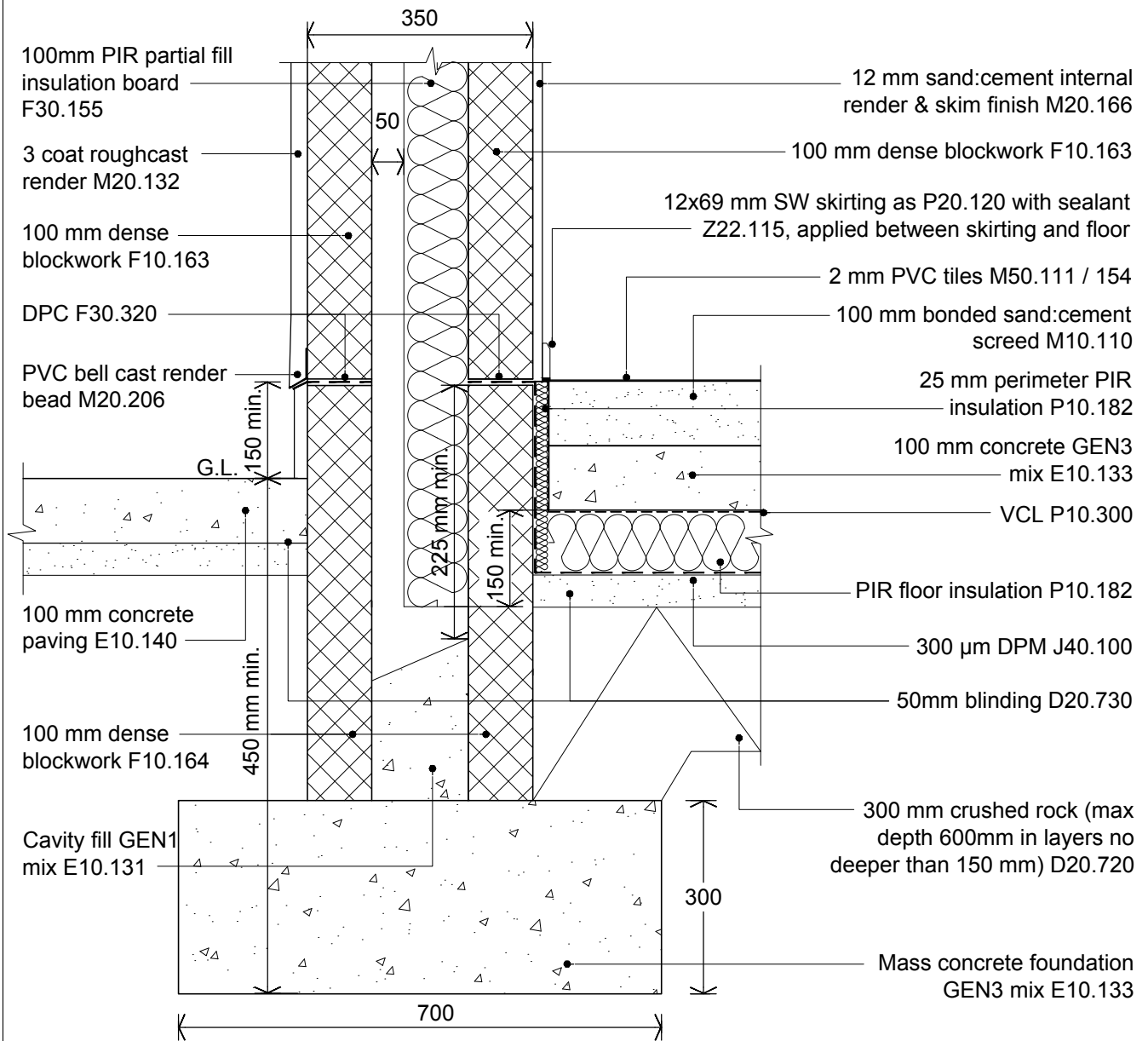

**Notes:**

- Stainless steel wall ties as F30.214 fixed and staggered at 900mm horizontal & 450mm vertically.
- Floor to have a U-value not greater than 0.22 W/m<sup>2</sup>K and walls not greater than 0.28 W/m<sup>2</sup>K.
- Where a facing brick outer leaf is preferred apply clause F10.151 (general brickwork clause to be completed by the Designer).
- Width and depth of foundations to be determined on site to suit ground conditions and to Building Control approval.

© NIHE 2017 DRAWINGS NOT TO BE SCALED DUE TO PRINTING DISTORTION



<b>TITLE</b>  <b>SOLID INSULATED GROUND FLOOR</b> Insulation below ground bearing slab	<b>DRAWN BY</b> P&S	<b>SCALE</b> 1:10	<b>DATE</b> Jan 91
	<b>DRAWING NO.</b>	A(01.11)01	
	<b>REV NO. &amp; DATE</b>	(9) 10/14	
	<b>REV NOTE:</b> Updated for Building Control		

\* This NIHE produced detail has been examined by The Building Control N.I. Standards Panel and has been considered reasonable in its interpretation of the relevant requirements of the Building Regulation NI 2012. There is no legal obligation for any Building Control department to adopt this recommendation & it is subject to revision in the event of changes to the legislation or other mitigating circumstances.

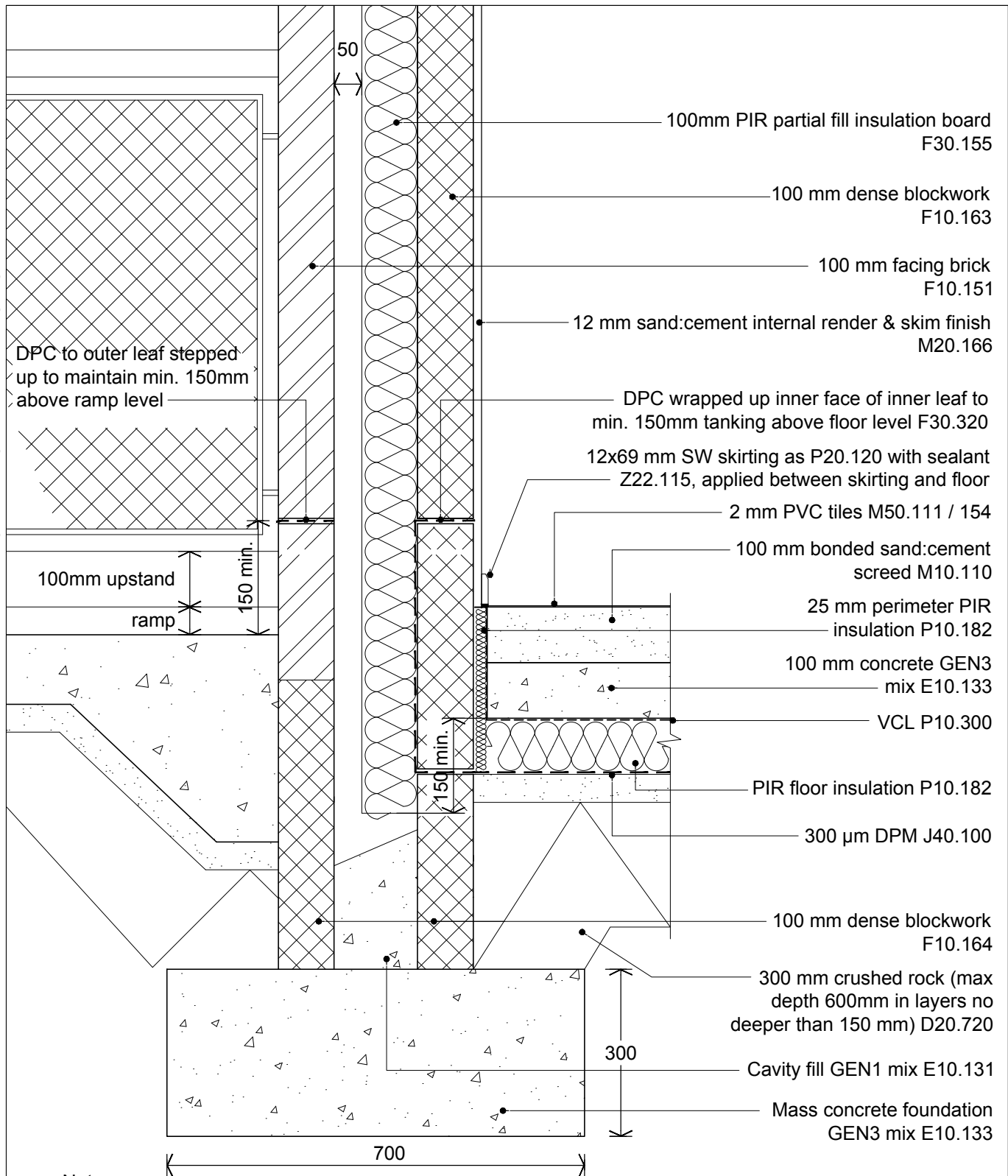

**Notes:**

- Stainless steel wall ties as F30.214 fixed and staggered at 900mm horizontal & 450mm vertically.
- Floor to have a U-value not greater than 0.22 W/m<sup>2</sup>K and walls not greater than 0.28 W/m<sup>2</sup>K.
- Where a facing brick outer leaf is preferred apply clause F10.151 (general brickwork clause to be completed by the Designer).
- Width and depth of foundations to be determined on site to suit ground conditions and to Building Control approval.
- See A(02.11)19 for level access detail.



TITLE  
**SOLID INSULATED  
 GROUND FLOOR**  
 Tanking to New Wall  
 Adjacent to Ramp

DRAWN BY <b>P&amp;S</b>	SCALE <b>1:10</b>	DATE <b>Nov 16</b>
DRAWING NO.	<b>A(01.11)02</b>	
REV NO. & DATE		
REV NOTE:		



\* This NIHE produced detail has been examined by The Building Control N.I. Standards Panel and has been considered reasonable in its interpretation of the relevant requirements of the Building Regulation NI 2012. There is no legal obligation for any Building Control department to adopt this recommendation & it is subject to revision in the event of changes to the legislation or other mitigating circumstances.

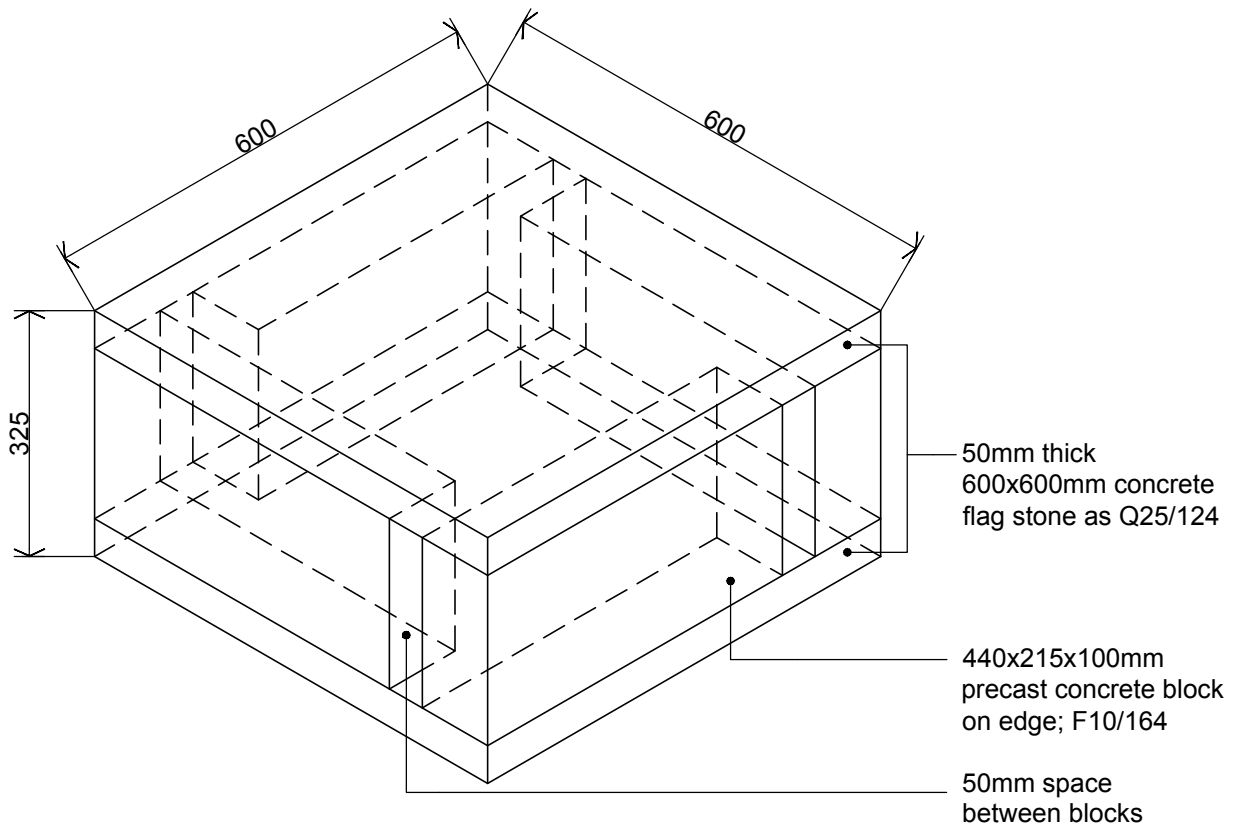

### ISOMETRIC VIEW OF SUMP

See Specification Clause U18/160

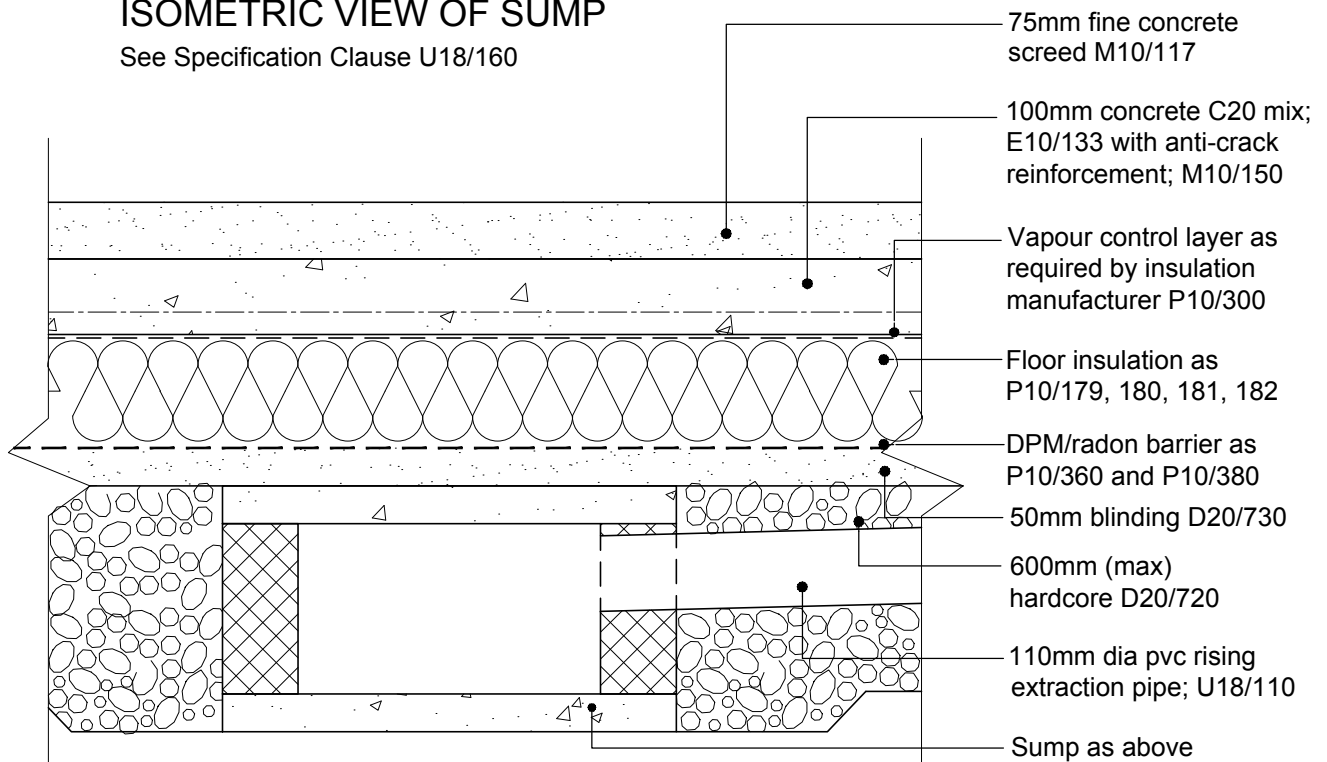

### SECTION THROUGH SUMP

- NB:
- See Building Regulations Technical Booklet C, October 2012.
  - For location of affected zones see *Radon in Dwellings in Northern Ireland: 2009 Review and Atlas*.
  - 300µm (1200 gauge) polyethylene DPM/radon barrier to be used in Zone 1 as P10/360 and 500µm (2000 gauge) in Zone 2 as P10/380.

SPECIFICATION REFERENCE: U18/160

**Housing Executive**

*BCNI Standards Panel Agreed \**

TITLE	RADON PROTECTION SUMP		
-------	-----------------------	--	--

DRAWN BY	TJB/CB	SCALE	1:10	DATE	Oct 95
DRAWING NO.	A(01.11)07				
REV NO. & DATE	(3) 09/12				
REV NOTE:	Updated to Bldg Regs Oct 2012				

© NIHE 2017 DRAWINGS NOT TO BE SCALED DUE TO PRINTING DISTORTION

\* This NIHE produced detail has been examined by The Building Control N.I. Standards Panel and has been considered reasonable in its interpretation of the relevant requirements of the Building Regulation NI 2012. There is no legal obligation for any Building Control department to adopt this recommendation & it is subject to revision in the event of changes to the legislation or other mitigating circumstances.

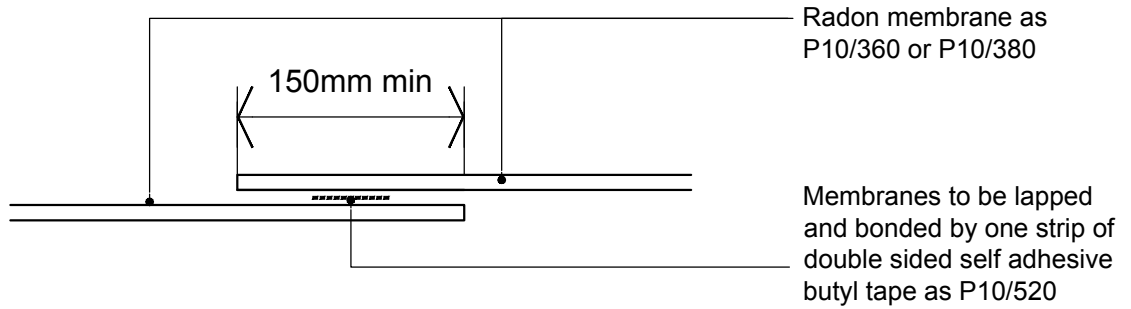

## MEMBRANE JOINTING

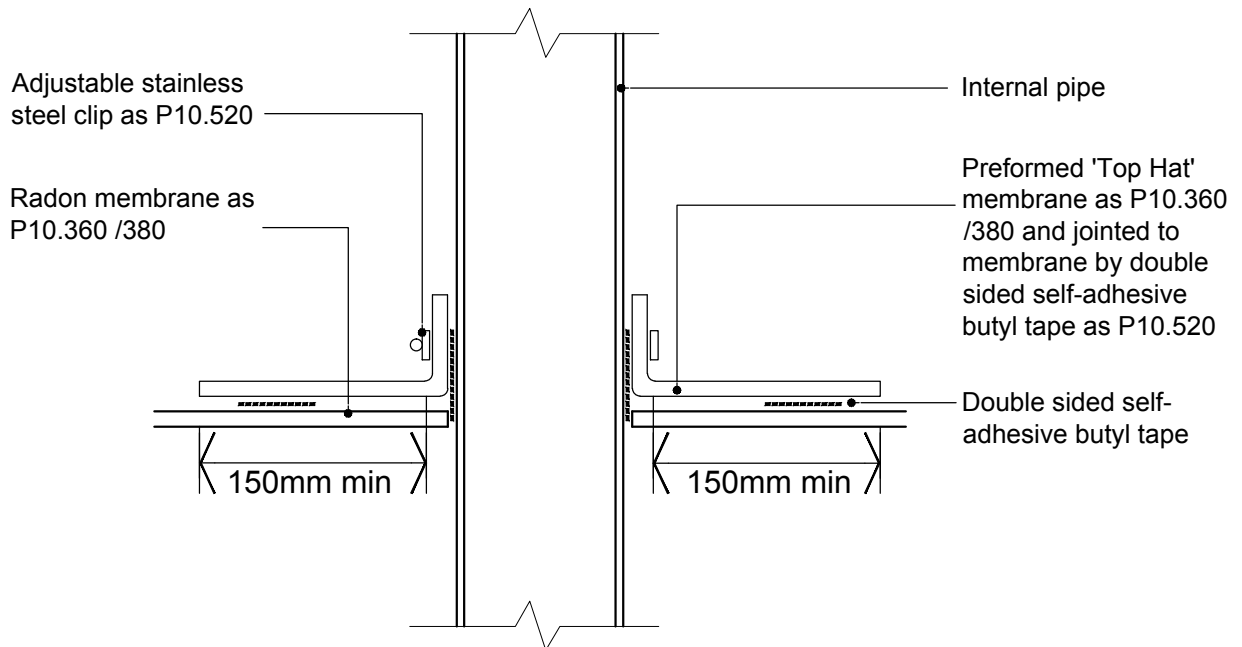

## SEALS AROUND SERVICE PIPES

### NOTES:

- See Building Regulations Technical Booklet C, October 2012.
- For location of affected zones see *Radon in Dwellings in Northern Ireland: 2009 Review and Atlas*.
- 300µm (1200 gauge) polyethylene DPM/radon barrier to be used in Zone 1 as P10.360 and 500µm (2000 gauge) in Zone 2 as P10/380.
- Installation as P10.520.

**Housing**  
Executive

**BCNI Standards**  
**Panel Agreed \***

TITLE

**RADON PROTECTION**

**MEMBRANE JOINTING  
AND SEALS AROUND  
SERVICE PIPES**

DRAWN BY  
**TJB/CB**

SCALE  
**1:5**

DATE  
**Oct 95**

DRAWING NO.

**A(01.11)08**

REV NO. & DATE

**(3) 01/13**

REV NOTE:

**Updated to revised spec**





\* This NIHE produced detail has been examined by The Building Control N.I. Standards Panel and has been considered reasonable in its interpretation of the relevant requirements of the Building Regulation NI 2012. There is no legal obligation for any Building Control department to adopt this recommendation & it is subject to revision in the event of changes to the legislation or other mitigating circumstances.

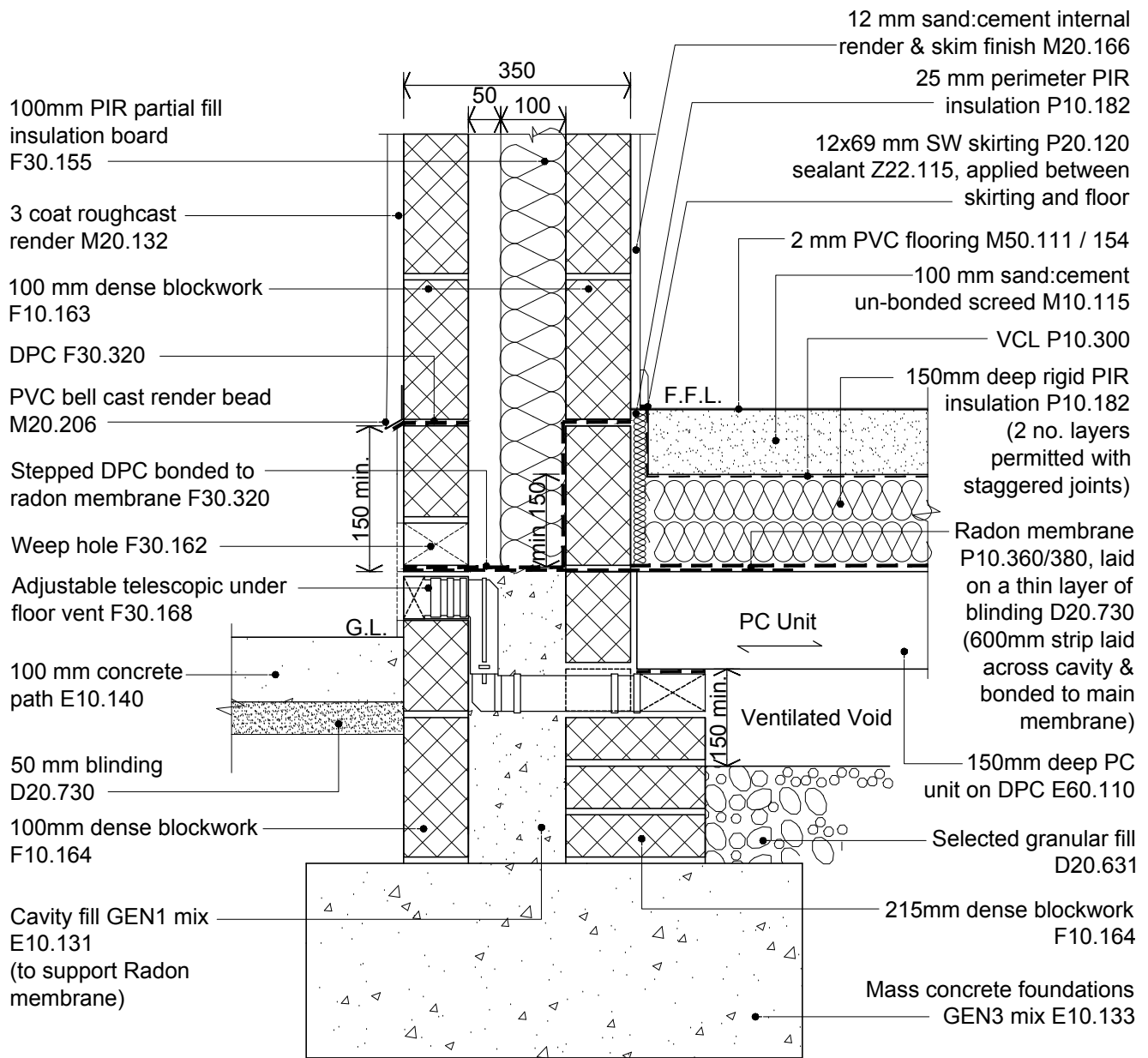

**NOTES:**

- See Radon in Dwellings in Northern Ireland: 2009 Review and Atlas for location of affected areas.
- 300µm (1200 gauge) polyethylene Radon barrier to be used in Zone 1 as P10.360 and 500µm (2000 gauge) in Zone 2 as P10.380.
- Refer to A(01.11)10 for Radon Protection at Internal & Party Wall Junctions.
- Radon membrane to be laid as P10.520 & detail A(01.11)08, & in accordance with manufacturer's instructions.
- PC concrete units to Structural Engineer's specification, laid in accordance with manufacturer's instructions on a continuous DPC, with minimum 100 mm bearing.
- Maintain a 150mm ventilated gap to the underside of PC units. If ventilation cannot be achieved, slab manufacturer to give consent to full fill under units, and to confirm that thickness of cover to reinforcement is in accordance with exposure class XC3, BS8500.
- Air bricks should be built into opposite walls to provide either 1500mm<sup>2</sup>/m or 500mm<sup>2</sup>/m<sup>2</sup> of floor space (whichever is greater).
- Stainless steel wall ties as F30.214 fixed and staggered at 900mm horizontal & 450mm vertically.
- Floor to have a U-value not greater than 0.22 W/m<sup>2</sup>K and walls not greater than 0.28 W/m<sup>2</sup>K.
- Width and depth of foundations to be determined on site to suit ground conditions and to Building Control approval.
- For a facing brick outer leaf apply clause F10.151 (general brickwork clause to be completed by the Designer).

**Housing Executive**

*BCNI Standards Panel Agreed \**

TITLE

**RADON PROTECTION  
EXTERNAL WALL  
150mm PC concrete  
suspended floor - vented**

DRAWN BY <b>P&amp;S</b>	SCALE <b>1:10</b>	DATE <b>Oct 95</b>
DRAWING NO.	<b>A(01.11)09</b>	
REV NO. & DATE	<b>(5) 11/16</b>	
REV NOTE: <b>Updated for Building Control</b>		



\* This NIHE produced detail has been examined by The Building Control N.I. Standards Panel and has been considered reasonable in its interpretation of the relevant requirements of the Building Regulation NI 2012. There is no legal obligation for any Building Control department to adopt this recommendation & it is subject to revision in the event of changes to the legislation or other mitigating circumstances.

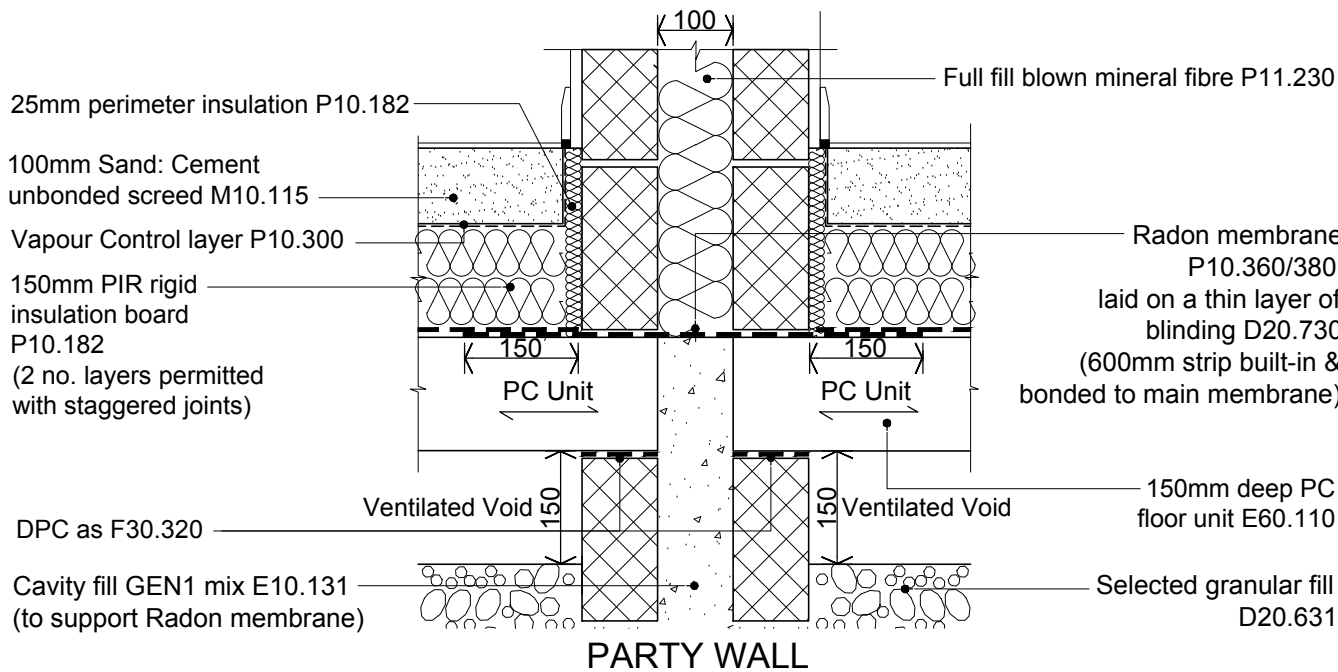

**PARTY WALL**

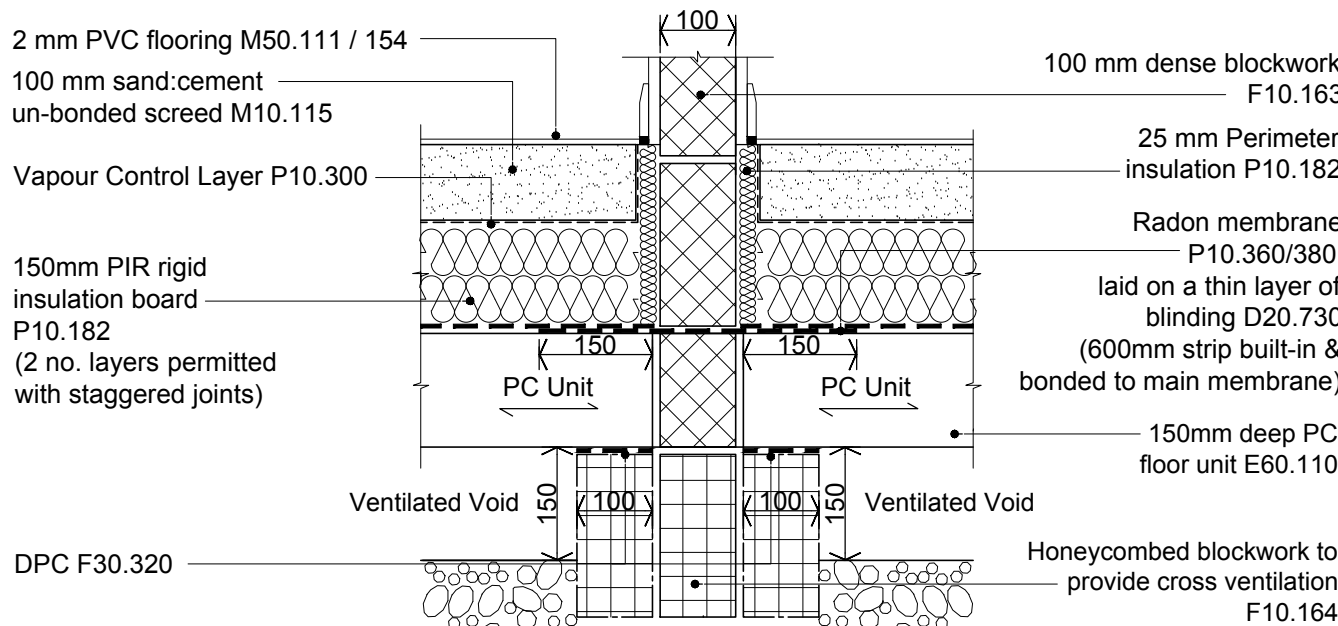

**100mm INTERNAL WALL**

**NOTES:**

- See Radon in Dwellings in Northern Ireland: 2009 Review and Atlas for location of affected areas.
- 300µm (1200 gauge) polyethylene Radon barrier to be used in Zone 1 as P10.360 and 500µm (2000 gauge) in Zone 2 as P10.380.
- Refer to A(01.11)09 for Radon protection at External wall.
- Radon membrane to be laid as P10.520 & detail A(01.11)08, & in accordance with manufacturer's instructions.
- PC concrete units to Structural Engineer's specification, laid in accordance with manufacturer's instructions on a continuous DPC, with minimum 100 mm bearing.
- Maintain a 150mm ventilated gap to the underside of PC units. If ventilation cannot be achieved, slab manufacturer to give consent to full fill under units, and to confirm that thickness of cover to reinforcement is in accordance with exposure class XC3, BS8500.
- Air bricks should be built in to opposite walls to provide either 1500mm<sup>2</sup>/m or 500mm<sup>2</sup>/m<sup>2</sup> of floor space (whichever is greater).
- Stainless steel wall ties as F30.214 fixed and staggered at 900mm horizontal & 450mm vertically.
- Floor to have a U-value not greater than 0.22 W/m<sup>2</sup>K.
- Width and depth of foundations to be determined on site to suit ground conditions and to Building Control approval.

TITLE	RADON PROTECTION PARTY & INTERNAL WALLS 150mm PC concrete suspended floor - vented		
-------	---	--	--

DRAWN BY	P&S	SCALE	1:10	DATE	Oct 95
DRAWING NO.	A(01.11)10				
REV NO. & DATE	(4) 11/16				
REV NOTE:	Updated for Building Control				



© NIHE 2017  
DRAWINGS NOT TO BE SCALED DUE TO PRINTING DISTORTION

\* This NIHE produced detail has been examined by The Building Control N.I. Standards Panel and has been considered reasonable in its interpretation of the relevant requirements of the Building Regulation NI 2012. There is no legal obligation for any Building Control department to adopt this recommendation & it is subject to revision in the event of changes to the legislation or other mitigating circumstances.

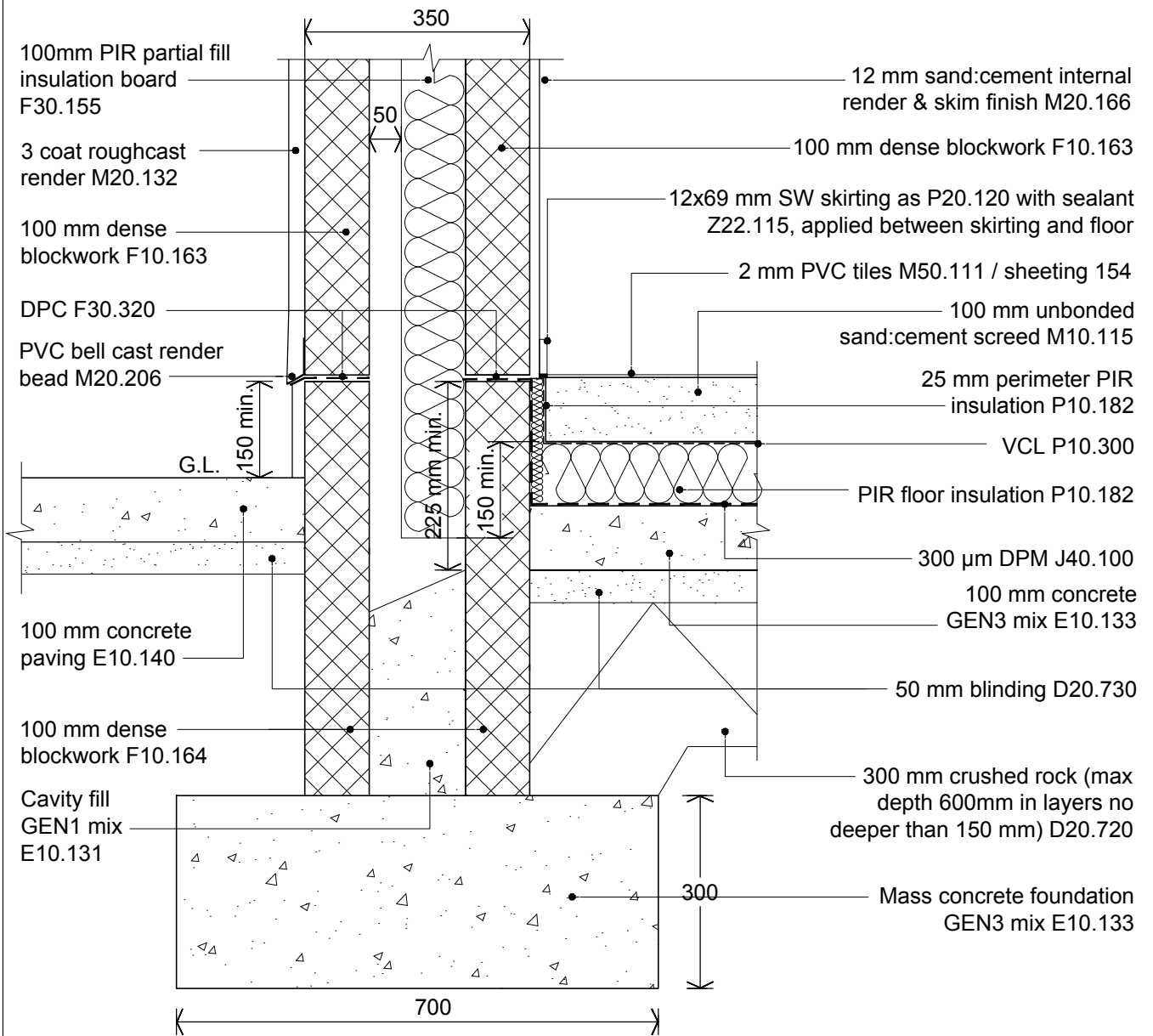

Notes:

- Stainless steel wall ties as F30.214 fixed and staggered at 900mm horizontal & 450mm vertically.
- Floor to have a U-value not greater than 0.22 W/m<sup>2</sup>K and walls not greater than 0.28 W/m<sup>2</sup>K.
- Where a facing brick outer leaf is preferred apply clause F10.151 (general brickwork clause to be completed by the Designer).
- Width and depth of foundations to be determined on site, to suit ground conditions and to Building Control approval.
- Ensure wall insulation is installed at least 150mm below the top of the floor insulation.

**Housing Executive**

*BCNI Standards Panel Agreed \**

TITLE

**SOLID INSULATED GROUND FLOOR  
Insulation Above  
Ground Bearing Slab**

DRAWN BY <b>P&amp;S</b>	SCALE <b>1:10</b>	DATE <b>Mar '15</b>
DRAWING NO.	<b>A(01.11)11</b>	
REV NO. & DATE		
REV NOTE:		



© NIHE 2017  
DRAWINGS NOT TO BE SCALED DUE TO PRINTING DISTORTION

\* This NIHE produced detail has been examined by The Building Control N.I. Standards Panel and has been considered reasonable in its interpretation of the relevant requirements of the Building Regulation NI 2012. There is no legal obligation for any Building Control department to adopt this recommendation & it is subject to revision in the event of changes to the legislation or other mitigating circumstances.

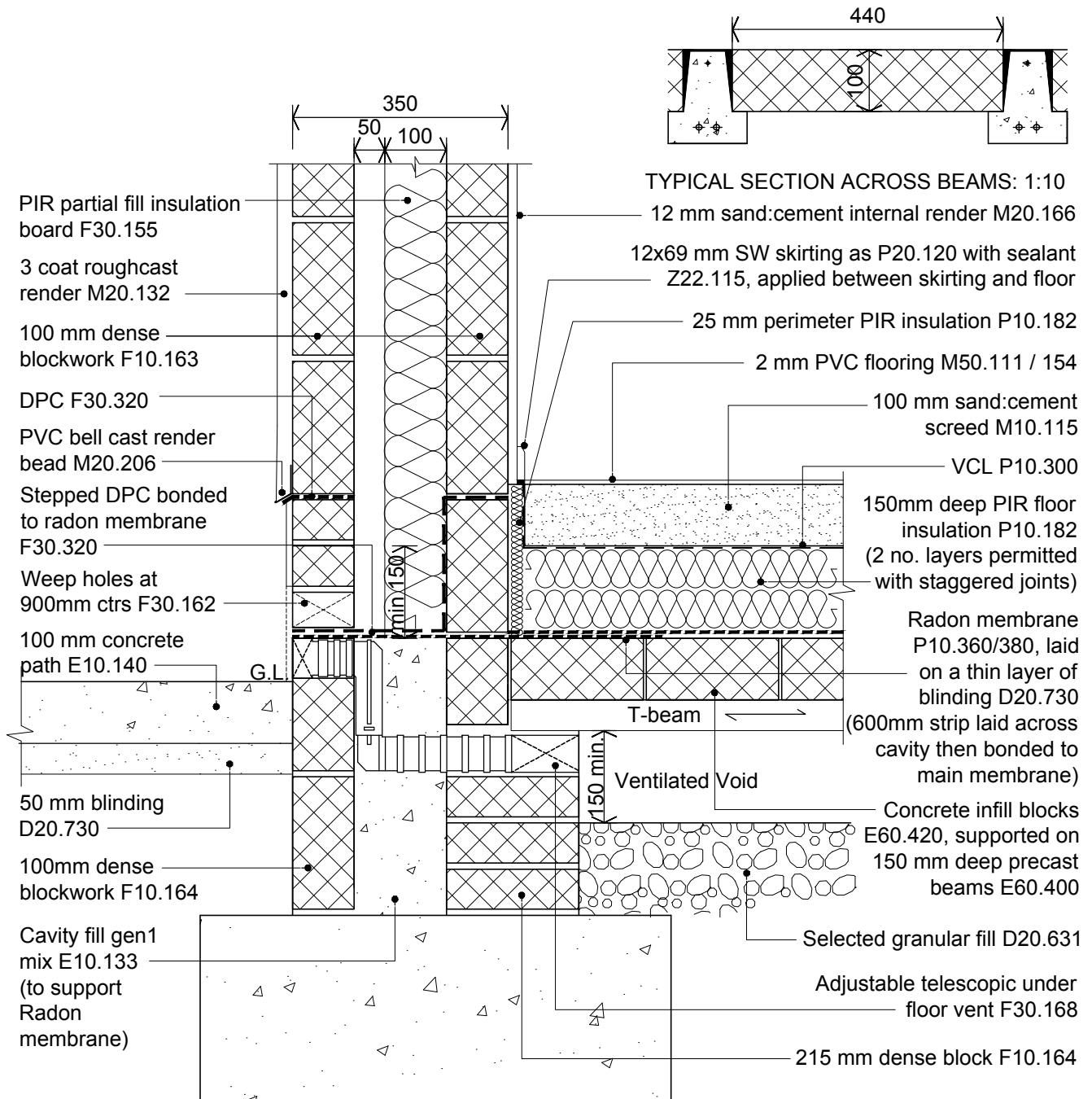

**NOTES:**

- See Radon in Dwellings in Northern Ireland: 2009 Review and Atlas for location of affected areas.
- 300µm (1200 gauge) polyethylene Radon barrier to be used in Zone 1 as P10.360 and 500µm (2000 gauge) in Zone 2 as P10.380.
- Radon membrane to be laid as P10.520 & detail A(01.11)08, & in accordance with manufacturer's instructions.
- Beam & Block construction to be designed & installed according to manufacturer's recommendations, with minimum 100 mm bearing on a continuous DPC.
- Maintain a 150mm ventilated gap to the underside of beam & block construction. If ventilation cannot be achieved, slab manufacturer to give consent to full fill under units, and to confirm that thickness of cover to reinforcement is in accordance with exposure class XC3, BS8500.
- Air bricks should be built into opposite walls to provide either 1500mm<sup>2</sup>/m or 500mm<sup>2</sup>/m<sup>2</sup> of floor space (whichever is greater).
- Stainless steel wall ties as F30.214 fixed and staggered at 900mm horizontal & 450mm vertically.
- Floor to have a U-value not greater than 0.22 W/m<sup>2</sup>K and walls not greater than 0.28 W/m<sup>2</sup>K.
- Width and depth of foundations to be determined on site to suit ground conditions and to Building Control approval.
- For a facing brick outer leaf apply clause F10.151 (general brickwork clause to be completed by the Designer).

**Housing Executive**

*BCNI Standards Panel Agreed \**

TITLE

**RADON PROTECTION  
EXTERNAL WALL  
beam & block suspended  
floor - vented**

DRAWN BY <b>P&amp;S</b>	SCALE <b>1:10</b>	DATE <b>Nov 16</b>
DRAWING NO.	<b>A(01.11)13</b>	
REV NO. & DATE		
REV NOTE:		



\* This NIHE produced detail has been examined by The Building Control N.I. Standards Panel and has been considered reasonable in its interpretation of the relevant requirements of the Building Regulation NI 2012. There is no legal obligation for any Building Control department to adopt this recommendation & it is subject to revision in the event of changes to the legislation or other mitigating circumstances.

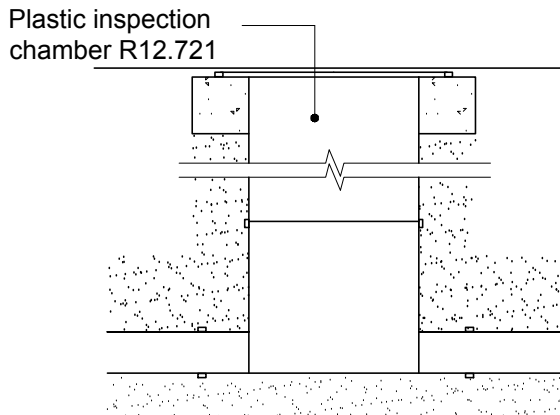

For bedding detail see A(01.12)05

1m max depth. of the invert to the inspection chamber

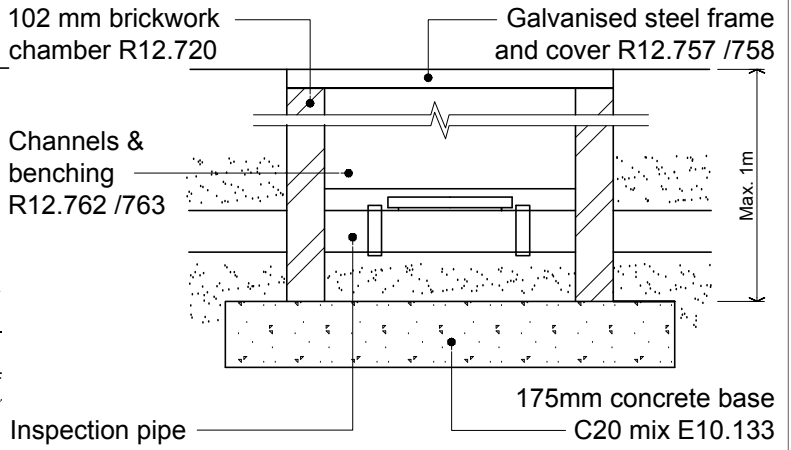

**PLASTIC INSPECTION CHAMBER (SECTION) BRICK INSPECTION CHAMBER (SECTION)**

**Notes:**

Drains passing through walls or foundations to have at least 50mm opening around the pipe.  
 Openings to be masked on both sides with rigid sheet material and sealed to prevent entry of gas (see Technical Booklet N diagram 3.6)

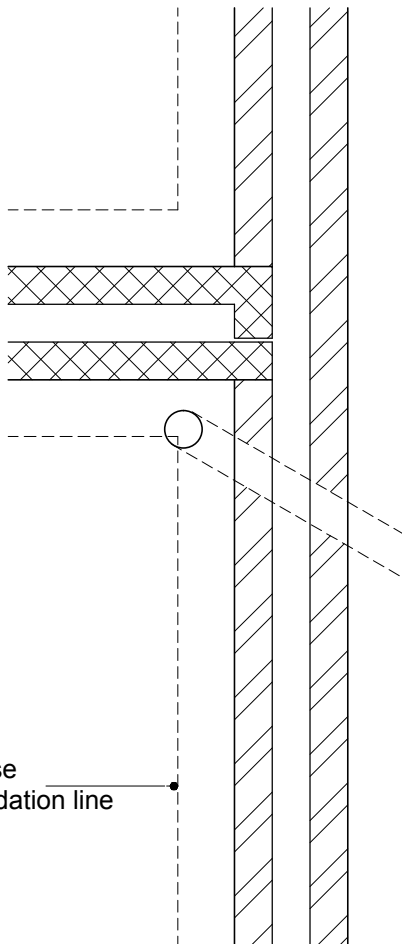

**PLAN OF BRICK INSPECTION CHAMBER**

Proprietary galvanised steel frame and cover bedded and seated in concrete surround R12.757 (for soft-standing) R12.758 (for hard-standing)

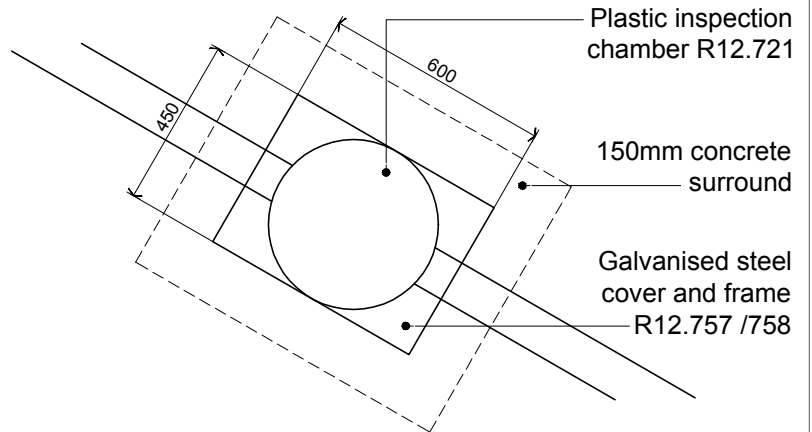

**PLAN OF PLASTIC INSPECTION CHAMBER**

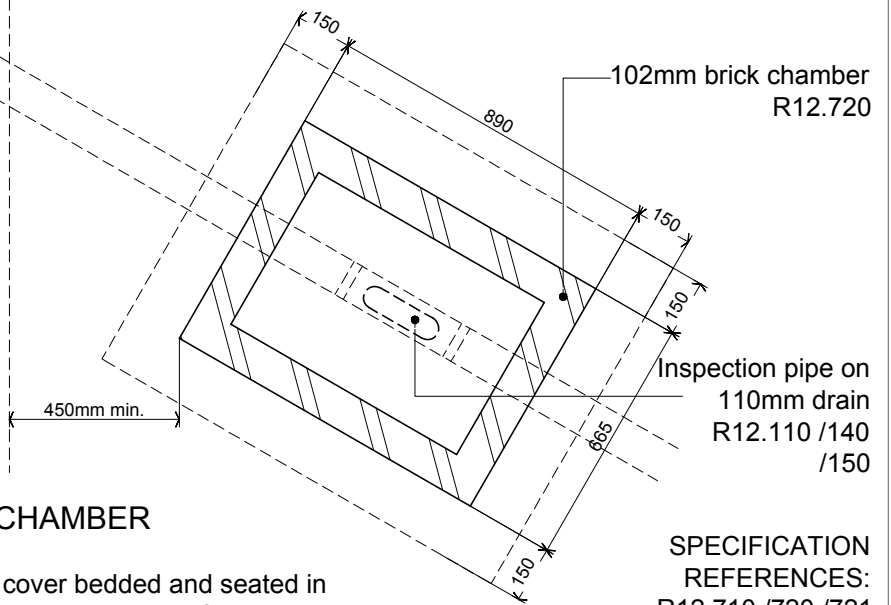

**SPECIFICATION REFERENCES:**  
 R12.710 /720 /721

TITLE	DRAWN BY	SCALE	DATE
DOMESTIC DRAINAGE (FOUL)	P&S	1:20	Mar 91
Inspection chamber types, detail plans and sections	DRAWING NO.	A(01.12)03	
	REV NO. & DATE	(5) 04/15	
	REV NOTE:	Updated for Building Control	

\* This NIHE produced detail has been examined by The Building Control N.I. Standards Panel and has been considered reasonable in its interpretation of the relevant requirements of the Building Regulation NI 2012. There is no legal obligation for any Building Control department to adopt this recommendation & it is subject to revision in the event of changes to the legislation or other mitigating circumstances.

**Housing Executive**  
BCNI Standards Panel Agreed\*

TITLE  
**EXTERNAL DOORS**  
Level Access to Existing Thresholds

SPECIFICATION REFERENCES: R12/617

DRAWN BY <b>P&amp;S</b>	SCALE 1:5	DATE Feb 91
DRAWING NO. A(02.11)03	REV NO. & DATE (5) 11/14	
REV NOTE: Updated to revised spec		

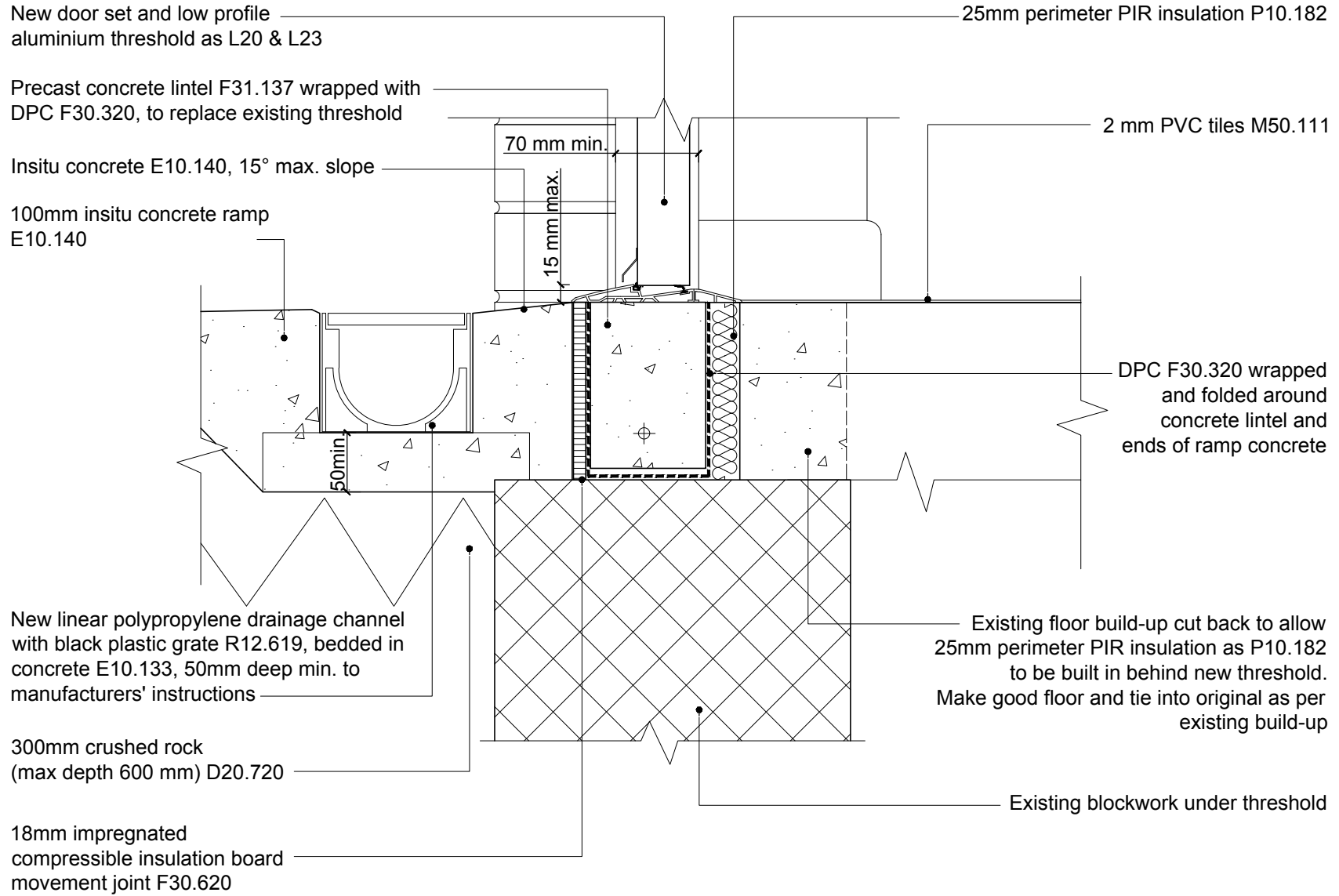

\* This NIHE produced detail has been examined by The Building Control N.I. Standards Panel and has been considered reasonable in its interpretation of the relevant requirements of the Building Regulation NI 2012. There is no legal obligation for any Building Control department to adopt this recommendation & it is subject to revision in the event of changes to the legislation or other mitigating circumstances.

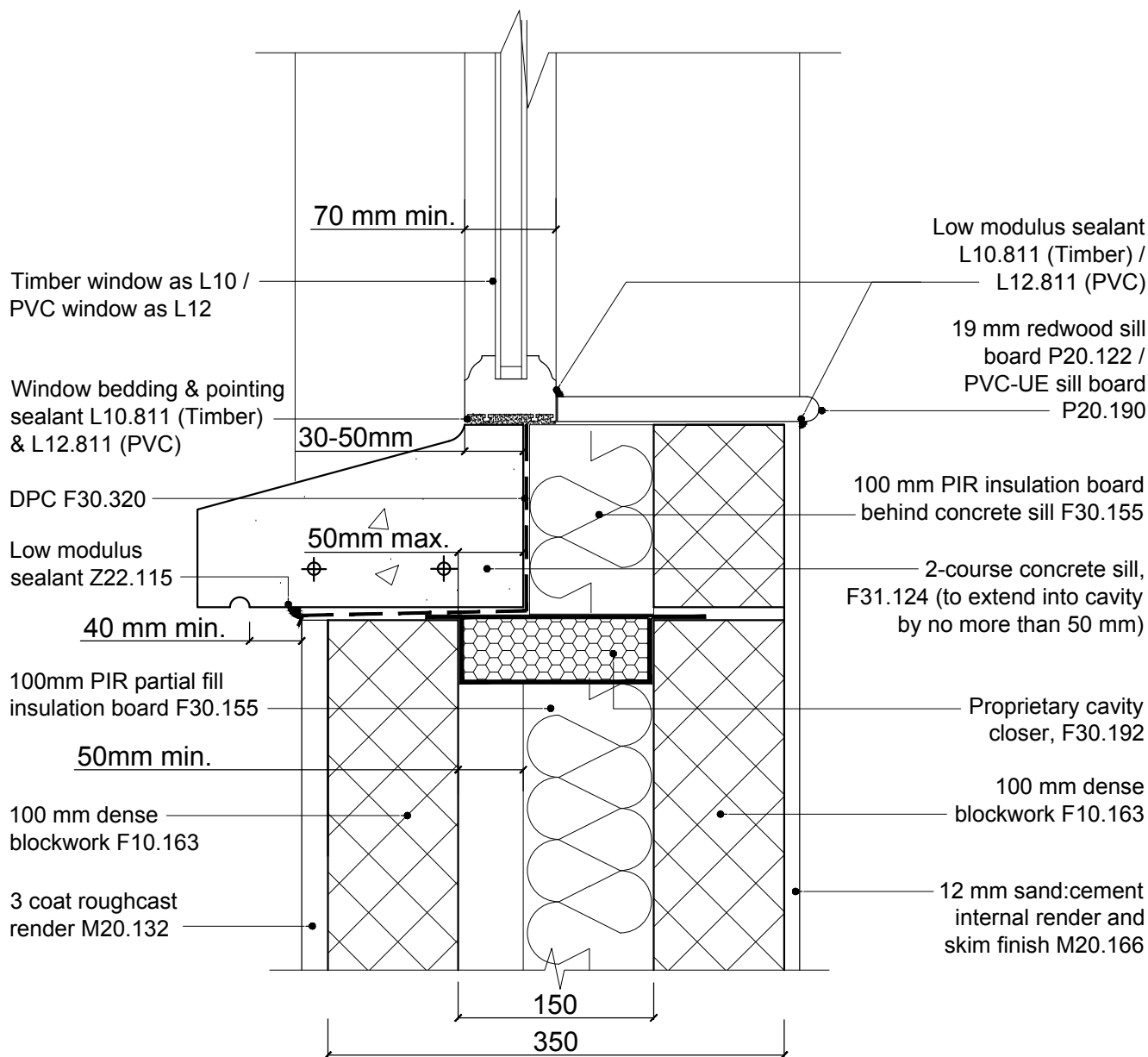

Notes:

- Proprietary cavity closer to provide 30 minutes fire resistance and thermal conductivity no greater than 0.038W/mK, F30.192.
- Stainless steel wall ties as F30.214 fixed and staggered at 900mm horizontal & 450mm vertically.
- Walls to have a U-value not greater than 0.28 W/m<sup>2</sup>K.
- Windows fitted as per NIHE Codes of Practice L10 (Timber) & L12 (PVC).
- Where a facing brick outer leaf is preferred apply clause F10.151 (general brickwork clause to be completed by the Designer) and clause F31.123 for concrete stooled sills.
- For 1-course concrete sills apply clauses F31.128 (blockwork) and F31.127 (brickwork).

**Housing Executive**

**BCNI Standards Panel Agreed \***

TITLE

STANDARD PRECAST CONCRETE SILL DETAIL  
350 mm brick or rendered cavity wall

DRAWN BY

P&S

SCALE

1:5

DATE

Dec 90

DRAWING NO.

A(02.11)08

REV NO. & DATE

(6) 10/14

REV NOTE:

Updated for Building Control



\* This NIHE produced detail has been examined by The Building Control N.I. Standards Panel and has been considered reasonable in its interpretation of the relevant requirements of the Building Regulation NI 2012. There is no legal obligation for any Building Control department to adopt this recommendation & it is subject to revision in the event of changes to the legislation or other mitigating circumstances.

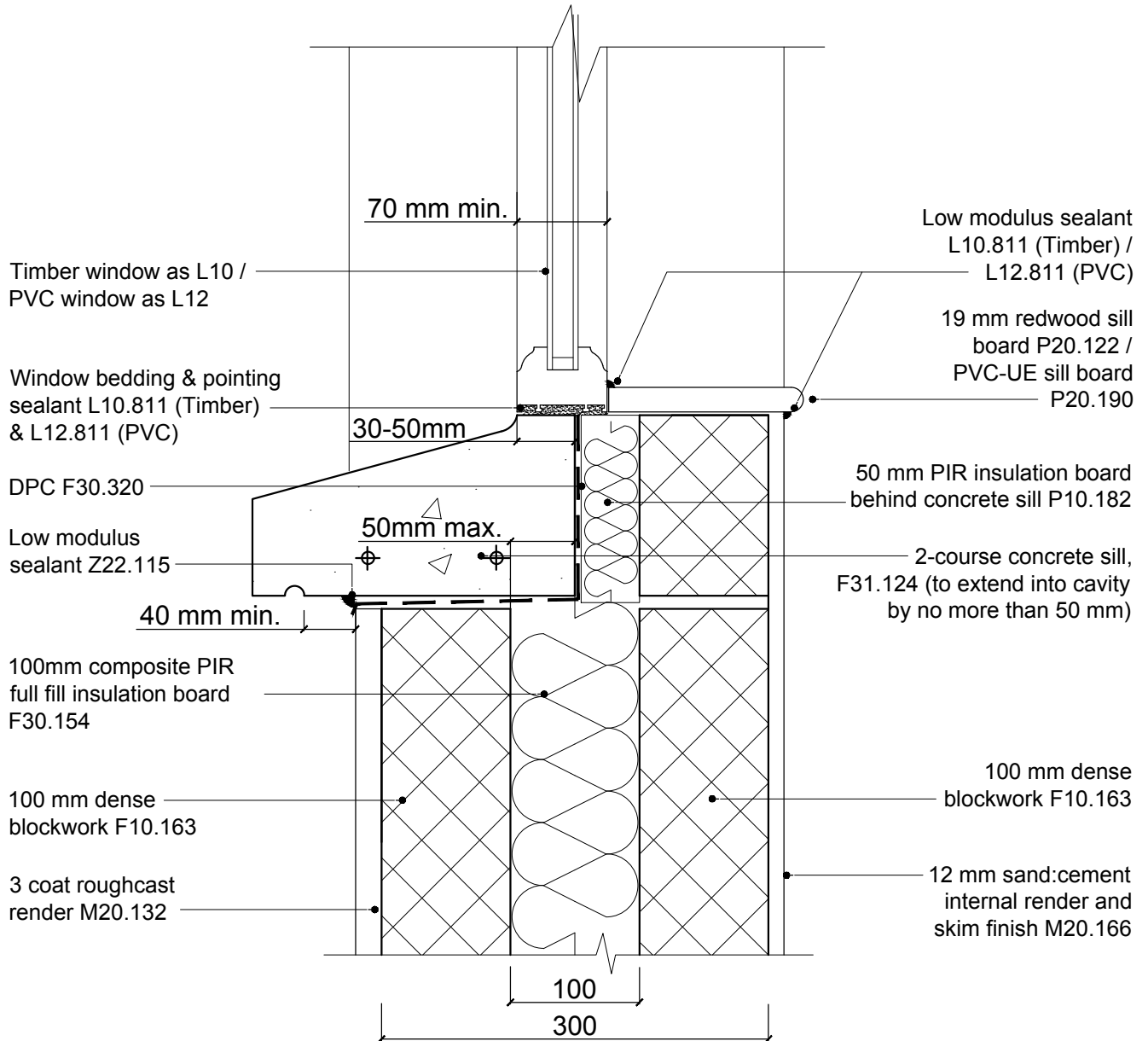

**Notes:**

- Stainless steel wall ties as F30.210 fixed and staggered at 900mm horizontal & 450mm vertically.
- A protective board should be used during construction of cavity wall to catch mortar droppings. Any mortar droppings that do fall within the cavity should be cleaned off.
- Walls to have a U-value not greater than 0.28 W/m<sup>2</sup>K.
- Windows fitted as per NIHE Codes of Practice L10 (Timber) & L12 (PVC).
- Where a facing brick outer leaf is preferred apply clause F10.151 (general brickwork clause to be completed by the Designer) and clause F31.123 for concrete stooled sills.
- For 1-course concrete sills apply clauses F31.128 (blockwork) and F31.127 (brickwork).
- Consideration should be given to the exposure of the site where brickwork outer leaf is proposed. (See insulation manufacturer's recommendations & consult Building Control).

**Housing Executive**

**BCNI Standards Panel Agreed \***

TITLE

ALTERNATIVE PRECAST CONCRETE SILL DETAIL  
300 mm brick or rendered cavity wall

DRAWN BY

P&S

SCALE

1:5

DATE

Dec 14

DRAWING NO.

A(02.11)09

REV NO. & DATE

REV NOTE:





\* This NIHE produced detail has been examined by The Building Control N.I. Standards Panel and has been considered reasonable in its interpretation of the relevant requirements of the Building Regulation NI 2012. There is no legal obligation for any Building Control department to adopt this recommendation & it is subject to revision in the event of changes to the legislation or other mitigating circumstances.

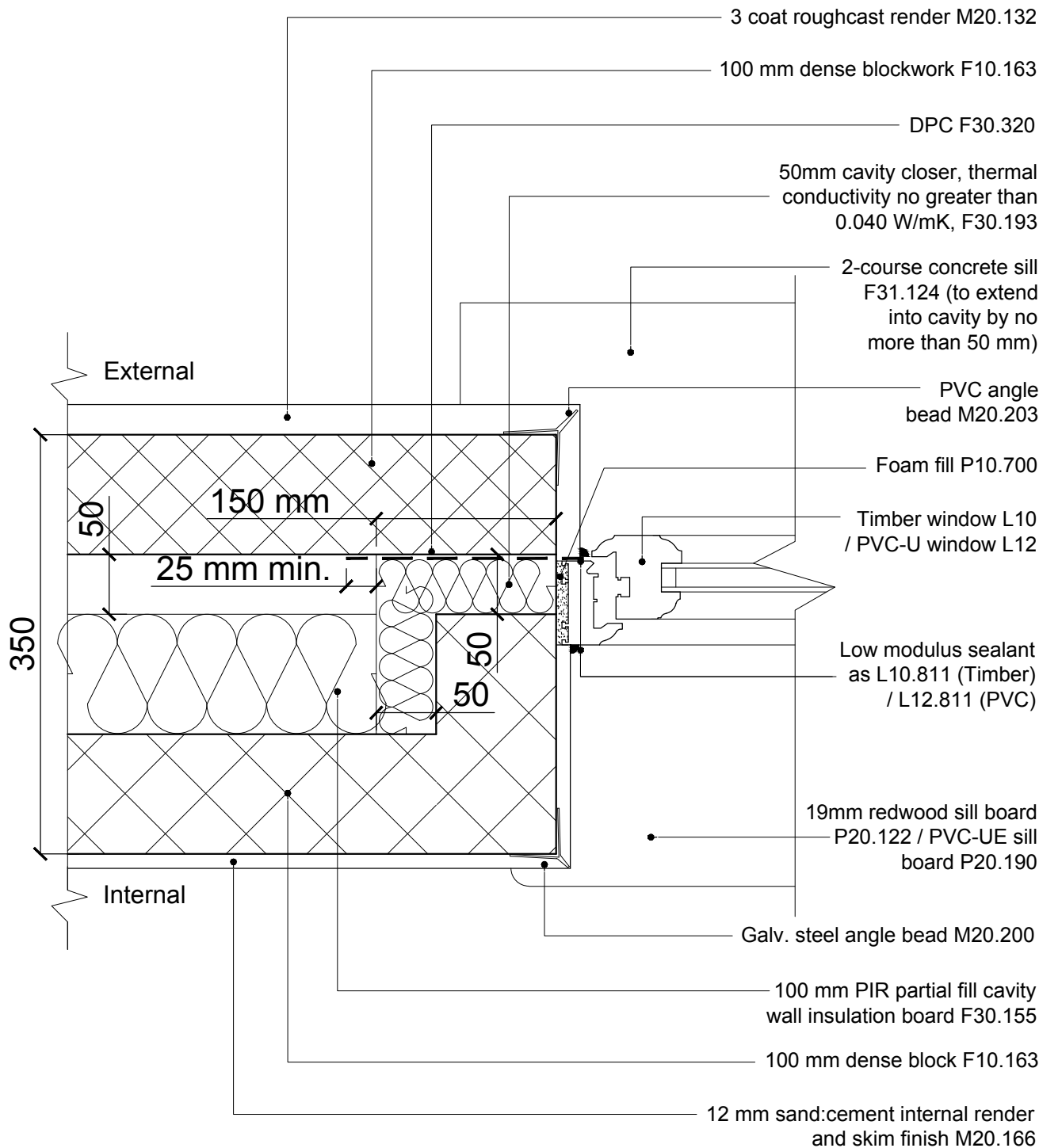

**Notes:**

- Cavity closer to provide 30 minutes fire resistance and thermal conductivity no greater than 0.040 W/mK, F30.193.
- Stainless steel wall ties as F30.214 fixed and staggered at 900mm horizontal & 450mm vertically.
- Walls to have a U-value not greater than 0.28 W/m<sup>2</sup>K.
- Windows fitted as per NIHE Codes of Practice L10 (Timber) & L12 (PVC).
- Where a facing brick outer leaf is preferred apply clause F10.151 (general brickwork clause to be completed by the Designer) and clause F31.123 for concrete stooled sills.
- For 1-course concrete sills apply clauses F31.128 (blockwork) and F31.127 (brickwork).

**Housing Executive**

**BCNI Standards Panel Agreed \***

TITLE

**INSULATED JAMB DETAIL FOR EXTERNAL OPENINGS**  
350 mm brick or rendered cavity wall

DRAWN BY  
**P&S**

SCALE  
**1:5**

DATE  
**Feb 91**

DRAWING NO.

**A(02.11)14**

REV NO. & DATE

**(7) 10/14**

REV NOTE:

**Updated for Building Control**



\* This NIHE produced detail has been examined by The Building Control N.I. Standards Panel and has been considered reasonable in its interpretation of the relevant requirements of the Building Regulation NI 2012. There is no legal obligation for any Building Control department to adopt this recommendation & it is subject to revision in the event of changes to the legislation or other mitigating circumstances.

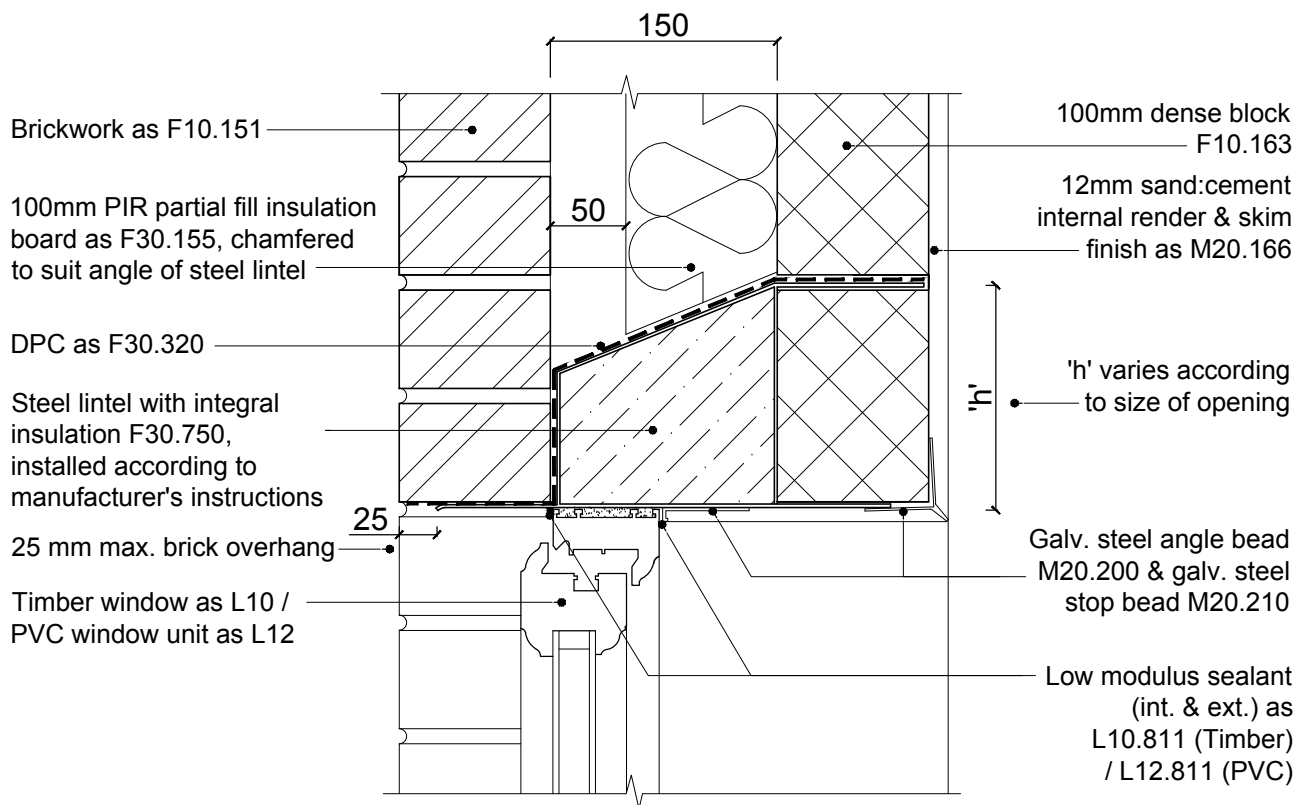

Notes:

- Stainless steel wall ties as F30.214 fixed and staggered at 900mm horizontal & 450mm vertically.
- Walls to have a U-value not greater than 0.28W/m<sup>2</sup>K.
- Windows fitted as per NIHE Code of Practice L10 (Timber) & L12 (PVC).
- Brickwork clause F10.151 is a general clause that must be completed by the Designer.
- Insulation to be chamfered to suit angle of steel lintel.

**Housing**  
Executive

**BCNI Standards**  
**Panel Agreed \***

TITLE

STANDARD STEEL  
LINTEL DETAIL B

DRAWN BY  
P&S

SCALE  
1:5

DATE  
Sept 00

DRAWING NO.

A(02.11)18

REV NO. & DATE

(3) 12/14

REV NOTE:

Updated for Building Control



\* This NIHE produced detail has been examined by The Building Control N.I. Standards Panel and has been considered reasonable in its interpretation of the relevant requirements of the Building Regulation NI 2012. There is no legal obligation for any Building Control department to adopt this recommendation & it is subject to revision in the event of changes to the legislation or other mitigating circumstances.

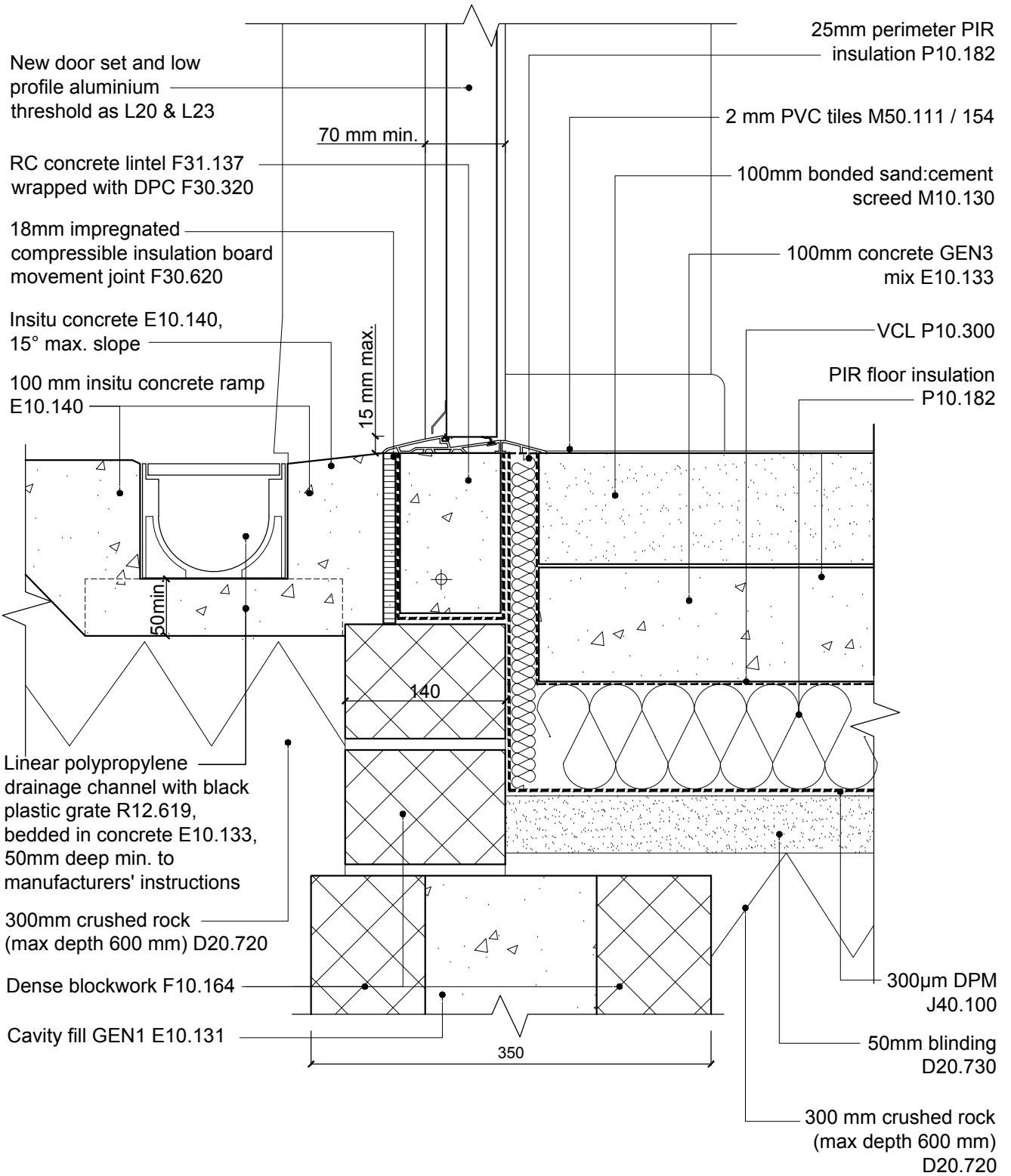

Note:  
 • Floor to have a U-value not greater than 0.22 W/m<sup>2</sup>K.

© NIHE 2017  
 DRAWINGS NOT TO BE SCALED DUE TO PRINTING DISTORTION

**Housing Executive**

BCNI Standards  
Panel Agreed \*

TITLE  
**NEW LEVEL ACCESS  
 EXTERNAL DOOR  
 THRESHOLD**

DRAWN BY <b>P&amp;S</b>	SCALE <b>1:5</b>	DATE <b>April 02</b>
DRAWING NO.	<b>A(02.11)19</b>	
REV NO. & DATE	<b>(3) 11/14</b>	
REV NOTE: <b>Updated to revised spec</b>		

\* This NIHE produced detail has been examined by The Building Control N.I. Standards Panel and has been considered reasonable in its interpretation of the relevant requirements of the Building Regulation NI 2012. There is no legal obligation for any Building Control department to adopt this recommendation & it is subject to revision in the event of changes to the legislation or other mitigating circumstances.

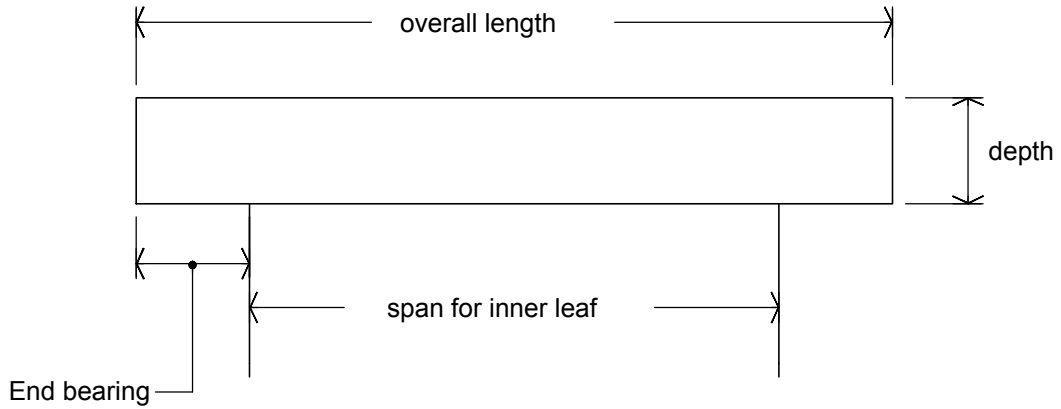

**INTERNAL ELEVATION**

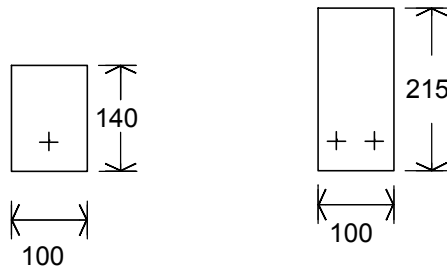

**SECTION DETAILS**

Span	Overall Length	End Bearing	Depth	Number of Courses	Size and Number of Reinforcement Bars
225	450	102	65	1	1no. T10mm
612	900	144	140	2	1no. T10mm
725	1025	150	140	2	1no. T10mm
837	1125	144	140	2	1no. T12mm
950	1250	150	140	2	1no. T12mm
1512	1800	144	215	3	1no. T16mm
1625	2000	188	215	3	2no. T12mm
1850	2250	200	215	3	2no. T12mm
2200	2600	200	215	3	2no. T16mm
2415	2800	193	215	3	2no. T16mm

**NOTES:**

- (1) Concrete mix to be as E10.135.
- (2) Lintels spanning 600-2100mm inclusive wide openings are designed to carry a timber floor loading up to spans of 4.5m, and lintels spanning over 2400mm openings are for 4m spans.
- (3) Special designs are required for lintels supporting floors greater than spans noted.
- (4) Also suitable for supporting outside leaf with no floor.
- (5) Cover to be: 40mm bottom, 20mm top and side.
- (6) 450 lintel for use over slow bend.
- (7) Lintels supporting concrete floors should be proprietary steel lintels as F30.750, designed by manufacturer.

SPECIFICATION REF: F31/137



<b>TITLE</b> <b>CONCRETOR SCHEDULE</b>  standard precast concrete lintels supporting timber floors	<b>DRAWN BY</b> P&S	<b>SCALE</b> 1:10	<b>DATE</b> July 90
	<b>DRAWING NO.</b> S(02.11)01		
	<b>REV NO. &amp; DATE</b> (5) 11/14		
	<b>REV NOTE:</b> Updated for Building Control		



© NIHE 2017 DRAWINGS NOT TO BE SCALED DUE TO PRINTING DISTORTION

\* This NIHE produced detail has been examined by The Building Control N.I. Standards Panel and has been considered reasonable in its interpretation of the relevant requirements of the Building Regulation NI 2012. There is no legal obligation for any Building Control department to adopt this recommendation & it is subject to revision in the event of changes to the legislation or other mitigating circumstances.

## NOTCHES

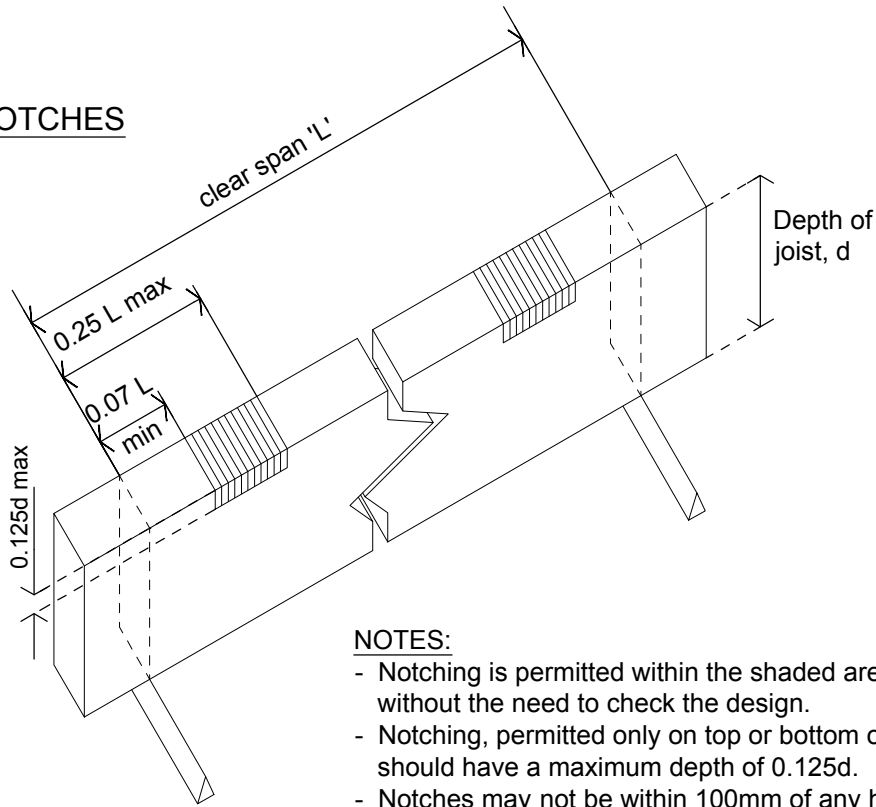

### NOTES:

- Notching is permitted within the shaded area without the need to check the design.
- Notching, permitted only on top or bottom of joist but not both, should have a maximum depth of 0.125d.
- Notches may not be within 100mm of any hole in the same joist.
- Alternatively a notch of 0.15d max. depth can occur in a joist not greater than 250mm deep between 0.1 L min. & 0.2 L max from the support.
- See Technical Booklet D dia. 4B.1(a) & (b).

## HOLES

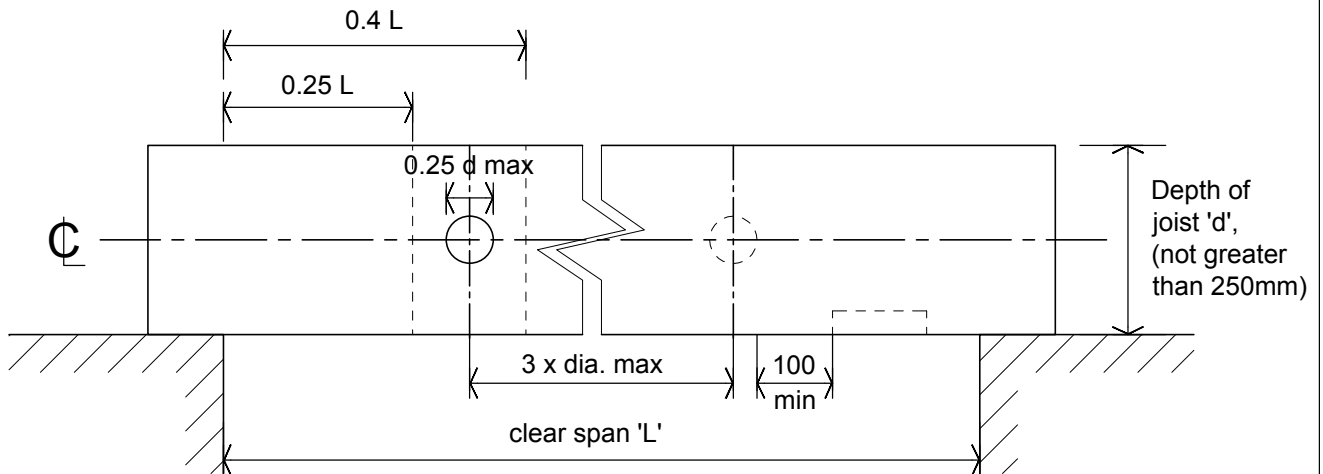

### NOTES:

- Holes are permitted between 0.25 L and 0.4 L from a support without the need to check the design.
- Holes should be on the centre line of the joist with a maximum diameter of 0.25d.
- Holes may not be within 3 x dia. of another hole or 100mm of a notch in the same joist.
- See Technical Booklet D dia. 4B.1(c)

SPECIFICATION REFERENCES: P31.230



TITLE	DRAWN BY P&S			SCALE NTS	DATE Apr 91
NOTCHING AND DRILLING OF JOISTS	DRAWING NO.		A(02.12)01		
	REV NO. & DATE		(4) 01/15		
REV NOTE: Updated for Building Control					

TITLE	DRAWN BY P&S			SCALE NTS	DATE Apr 91
NOTCHING AND DRILLING OF JOISTS	DRAWING NO.		A(02.12)01		
	REV NO. & DATE		(4) 01/15		
REV NOTE: Updated for Building Control					

\* This NIHE produced detail has been examined by The Building Control N.I. Standards Panel and has been considered reasonable in its interpretation of the relevant requirements of the Building Regulation NI 2012. There is no legal obligation for any Building Control department to adopt this recommendation & it is subject to revision in the event of changes to the legislation or other mitigating circumstances.

SPECIFICATION REFERENCES: K11/110, 200

- 12x69 skirting P20/120
- 5mm gap filled with flexible sealant Z22/115
- 9mm thick 75x45 self-adhesive polystyrene foam isolation pad
- Acoustic cradled particleboard floating floor as K11/200
- Proprietary adjustable cradle system with isolation pads as K11/200

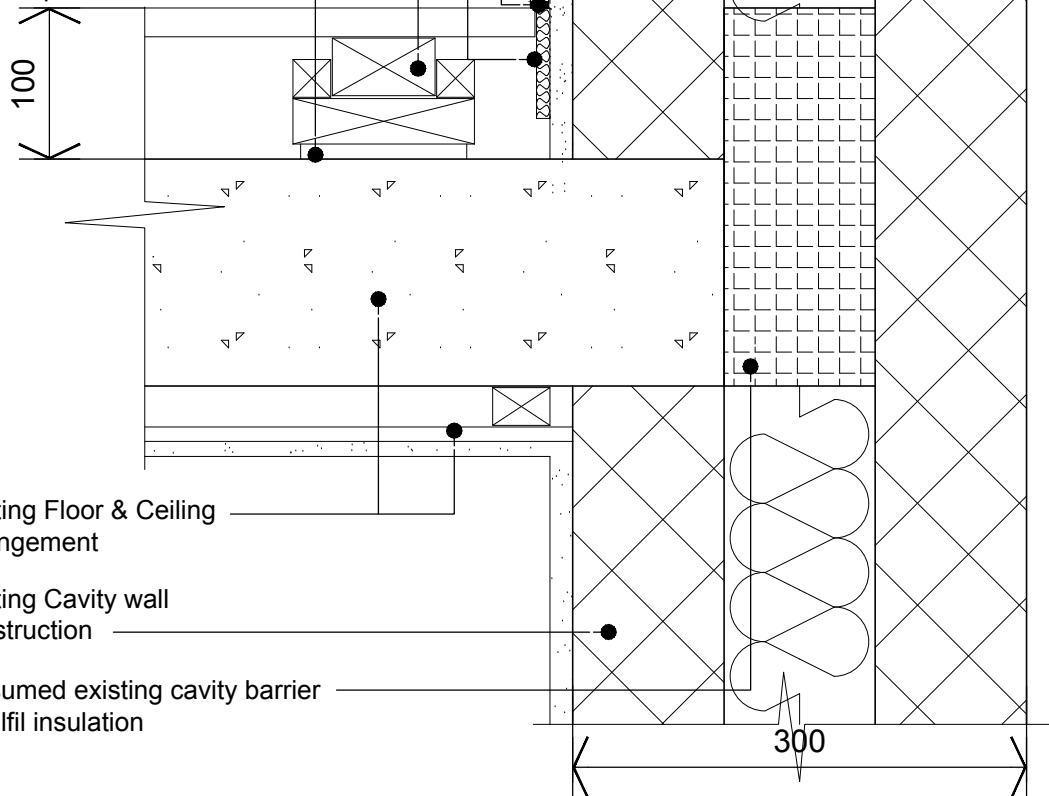

**NOTES:**

- Spacing of cradles should comply with BS EN1991-1-7:2006+A1:2014 for domestic floor loadings: 0.4kN.m<sup>2</sup> dead load & 1.5kN.m<sup>2</sup> distributed load.
- Additional supports may be required under heavy appliances, eg. baths.
- Ensure manufacturer of floating floor system has a laboratory sound test report that demonstrates compliance with performance criteria.
- Renovation works to existing residential units should cause no new or greater contravention to the Regulations.
- New Build projects and Material Change of Use projects must comply with Building Regulations TB-G.
- Where floor & ceiling heights are restrictive, consider laying a resilient overlay on concrete floor as P10.330.

© NIHE 2017

DRAWINGS NOT TO BE SCALED DUE TO PRINTING DISTORTION

TITLE  
**SOUND INSULATED  
 FLOATING FLOOR TO  
 EXISTING FLATS  
 (IRREGULAR SURFACES)**

DRAWN BY <b>P&amp;S</b>	SCALE <b>1:5</b>	DATE <b>Apr 91</b>
DRAWING NO.	<b>A(02.12)03</b>	
REV NO. & DATE	<b>(6) 07/16</b>	
REV NOTE: <b>Updated for Building Control</b>		



\* This NIHE produced detail has been examined by The Building Control N.I. Standards Panel and has been considered reasonable in its interpretation of the relevant requirements of the Building Regulation NI 2012. There is no legal obligation for any Building Control department to adopt this recommendation & it is subject to revision in the event of changes to the legislation or other mitigating circumstances.

SPECIFICATION REFERENCES: K11/120, 210

15x38mm timber ground G20/210

12x69 Skirting P20/120

5mm gap filled with flexible sealant Z22/115

9mm thick 75x44 self-adhesive polystyrene foam isolation pad or flexible sealant as Z22.115

Acoustic battened particleboard floating floor K11/210

Proprietary flanged acoustic floor clips as K11/210

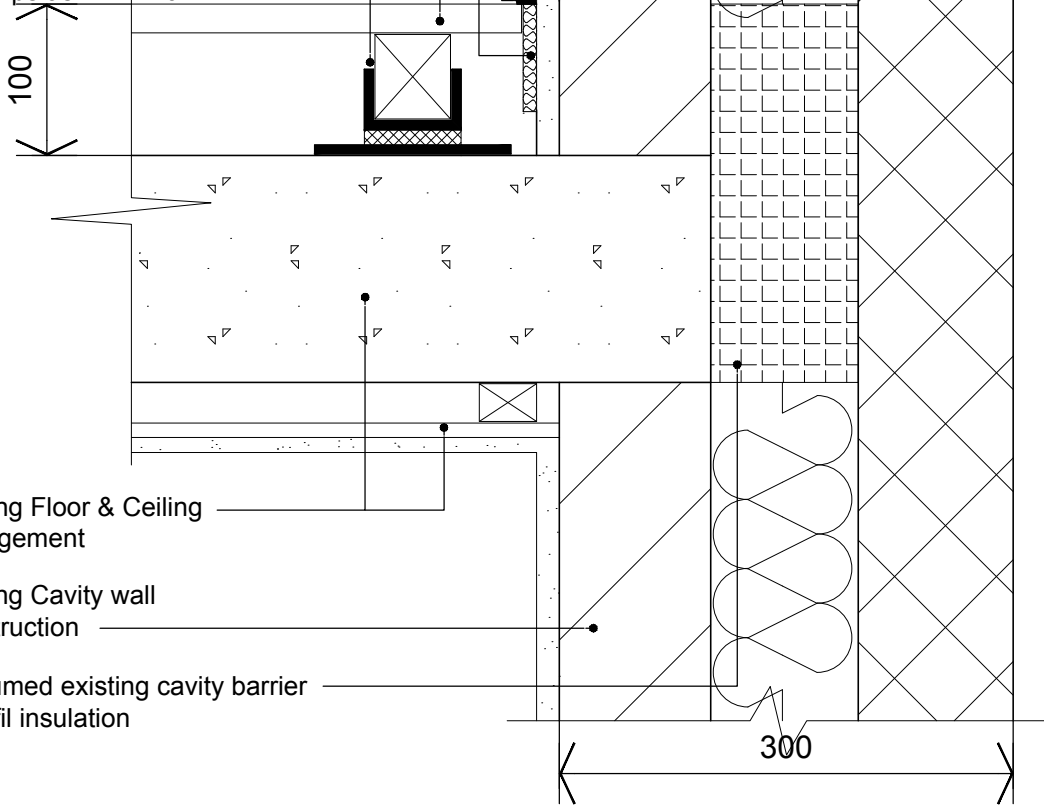

Existing Floor & Ceiling Arrangement

Existing Cavity wall Construction

Presumed existing cavity barrier or fulfil insulation

**NOTES:**

- Spacing of cradles should comply with BS EN1991-1-7:2006+A1:2014 for domestic floor loadings: 0.4kN.m<sup>2</sup> dead load & 1.5kN.m<sup>2</sup> distributed load.
- Additional supports may be required under heavy appliances, eg. baths.
- Ensure manufacturer of floating floor system has a laboratory sound test report that demonstrates compliance with performance criteria.
- Renovation works to existing residential units should cause no new or greater contravention to the Regulations.
- New Build projects and Material Change of Use projects must comply with Building Regulations TB-G.
- Where floor & ceiling heights are restrictive, consider laying a resilient overlay on concrete floor as P10.330.

© NIHE 2017

DRAWINGS NOT TO BE SCALED DUE TO PRINTING DISTORTION

TITLE	DRAWN BY	SCALE	DATE
SOUND INSULATED FLOATING FLOOR TO EXISTING FLATS (REGULAR SURFACES)	P&S	1:5	Apr 91
	DRAWING NO.	A(02.12)04	
	REV NO. & DATE	(6) 07/16	
	REV NOTE:	Revised notes	

REV NOTE:	Revised notes	
-----------	---------------	--

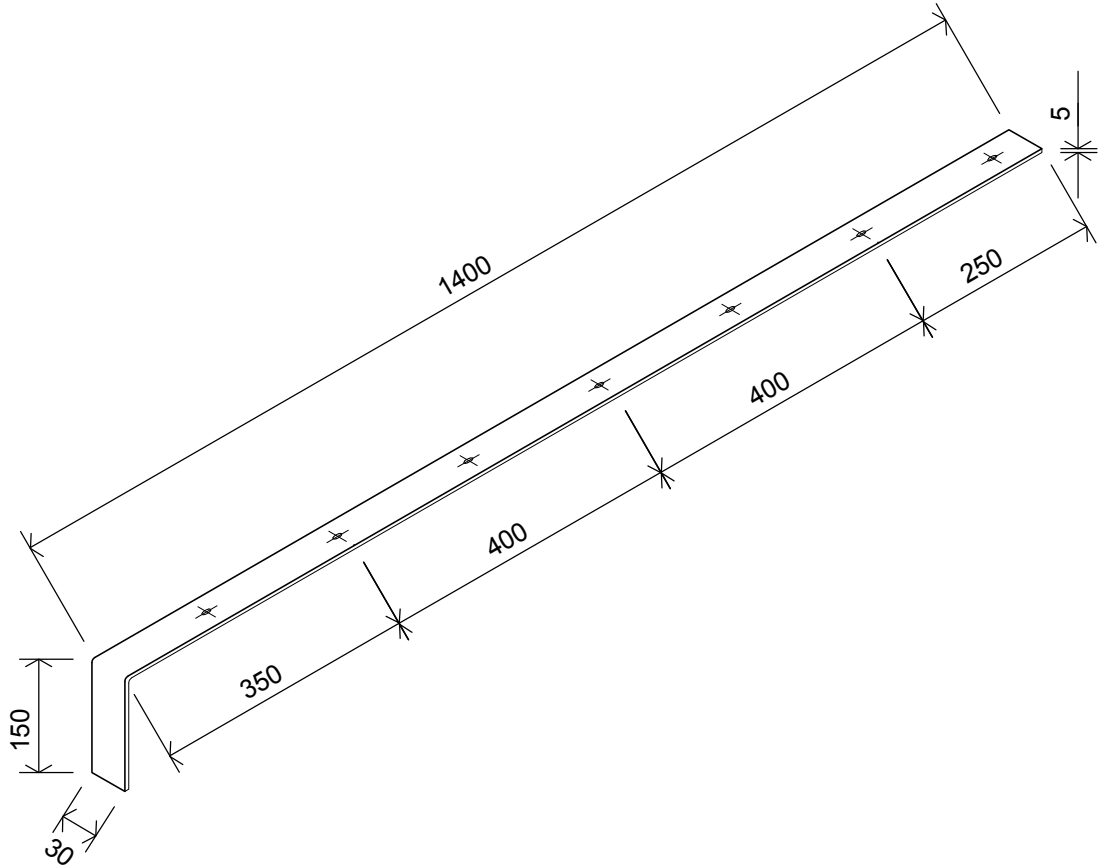

ISOMETRIC SKETCH OF  
LATERAL RESTRAINT  
STRAP G20/830

© NIHE 2017  
DRAWINGS NOT TO BE SCALED DUE TO PRINTING DISTORTION



TITLE  LATERAL RESTRAINT STRAP	DRAWN BY TJB	SCALE N.T.S.	DATE Apr 91
	DRAWING NO.	C(02.14)01	
	REV NO. & DATE	(1) 3/92	
	REV NOTE:		





\* This NIHE produced detail has been examined by The Building Control N.I. Standards Panel and has been considered reasonable in its interpretation of the relevant requirements of the Building Regulation NI 2012. There is no legal obligation for any Building Control department to adopt this recommendation & it is subject to revision in the event of changes to the legislation or other mitigating circumstances.

Lead tray to be dressed up face of liner and under lead cover flashing, cover flashing to be turned over top of liner H71/455

Bedded and haunched Waterproof Mortar F30/937

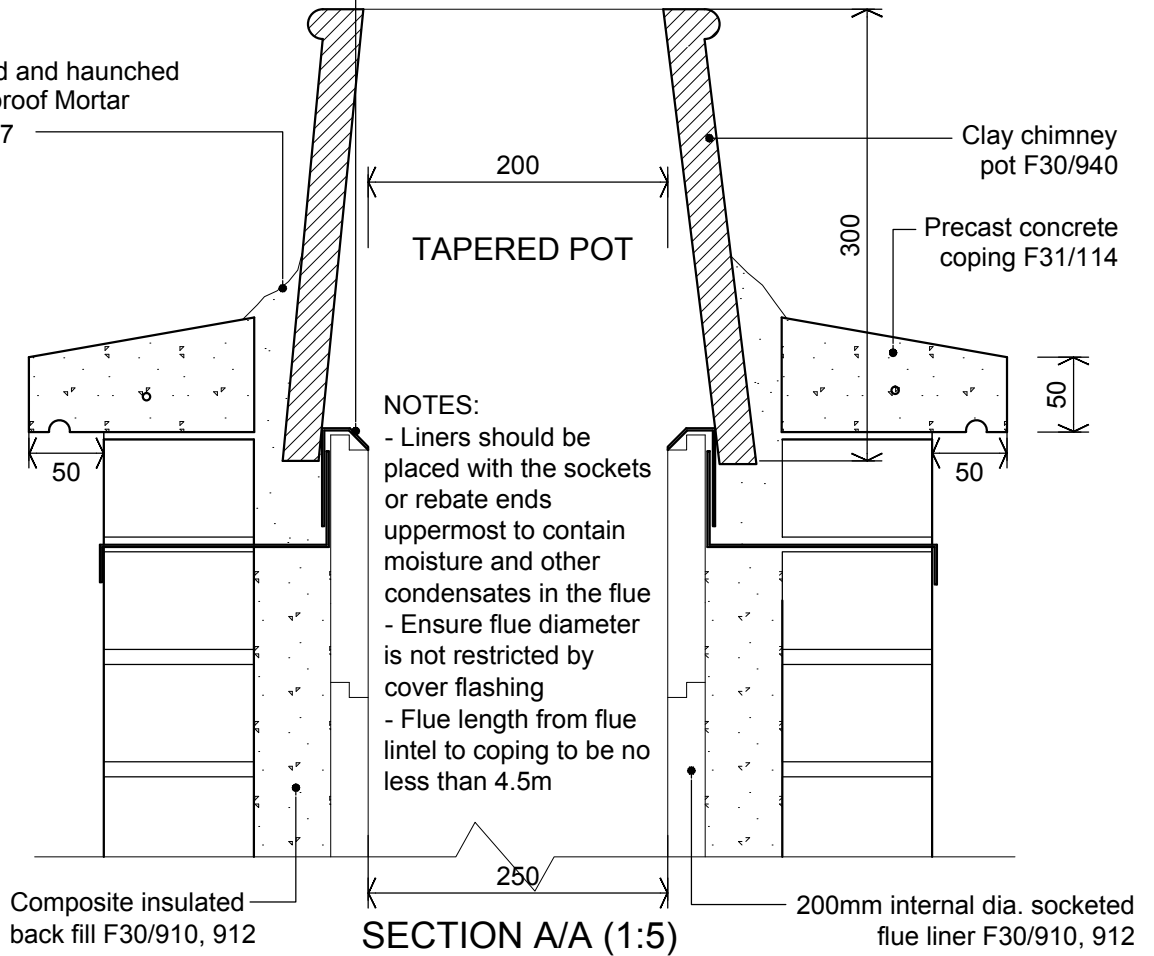

NOTES:

- Liners should be placed with the sockets or rebate ends uppermost to contain moisture and other condensates in the flue
- Ensure flue diameter is not restricted by cover flashing
- Flue length from flue lintel to coping to be no less than 4.5m

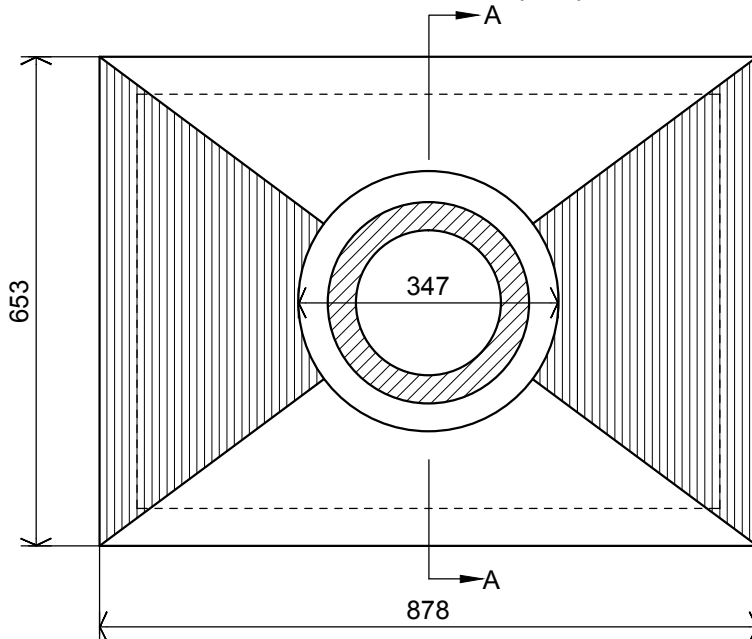

SEE DETAIL A(04.11)01 FOR CHIMNEY / ROOF JUNCTION

SPECIFICATION REFERENCE: F31/114

**Housing Executive**

**BCNI Standards Panel Agreed \***

TITLE

BRICK FLUE COPING DETAIL (TAPERED POT) PLAN AND SECTION

DRAWN BY

P&S

SCALE

1:10/1:5

DATE

Apr 91

DRAWING NO.

A(03.12)03

REV NO. & DATE

(7) 07/16

REV NOTE:

Reference to A(04.11)01



\* This NIHE produced detail has been examined by The Building Control N.I. Standards Panel and has been considered reasonable in its interpretation of the relevant requirements of the Building Regulation NI 2012. There is no legal obligation for any Building Control department to adopt this recommendation & it is subject to revision in the event of changes to the legislation or other mitigating circumstances.

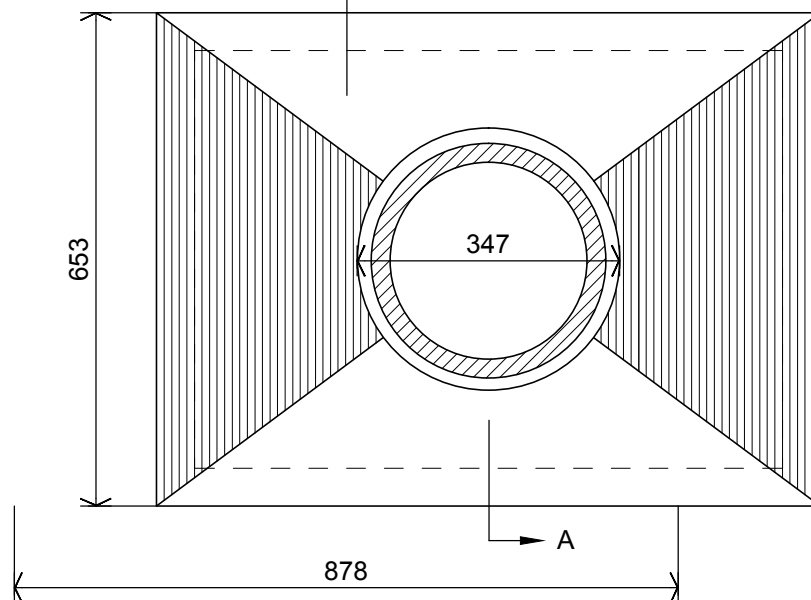
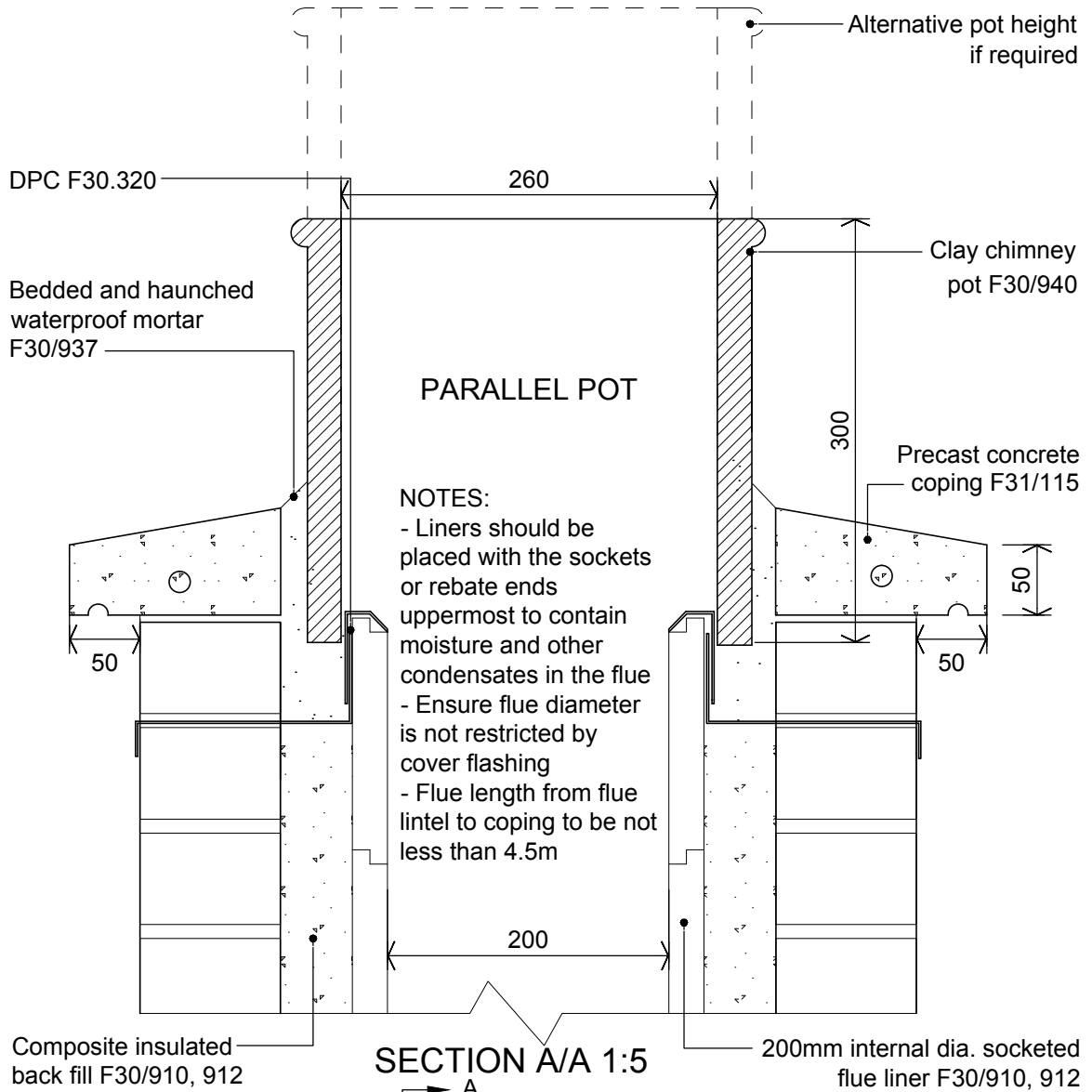

SEE DETAIL A(04.11)01 FOR CHIMNEY / ROOF JUNCTION

SPECIFICATION REFERENCE: F31/115



TITLE	BRICK FLUE COPING DETAIL (PARALLEL POT) PLAN AND SECTION	
-------	--	--

DRAWN BY	SCALE	DATE
P&S	1:10/1:5	Apr 91
DRAWING NO.	A(03.12)04	
REV NO. & DATE	(7) 07/16	
REV NOTE:	Reference to A(04.11)01	



\* This NIHE produced detail has been examined by The Building Control N.I. Standards Panel and has been considered reasonable in its interpretation of the relevant requirements of the Building Regulation NI 2012. There is no legal obligation for any Building Control department to adopt this recommendation & it is subject to revision in the event of changes to the legislation or other mitigating circumstances.

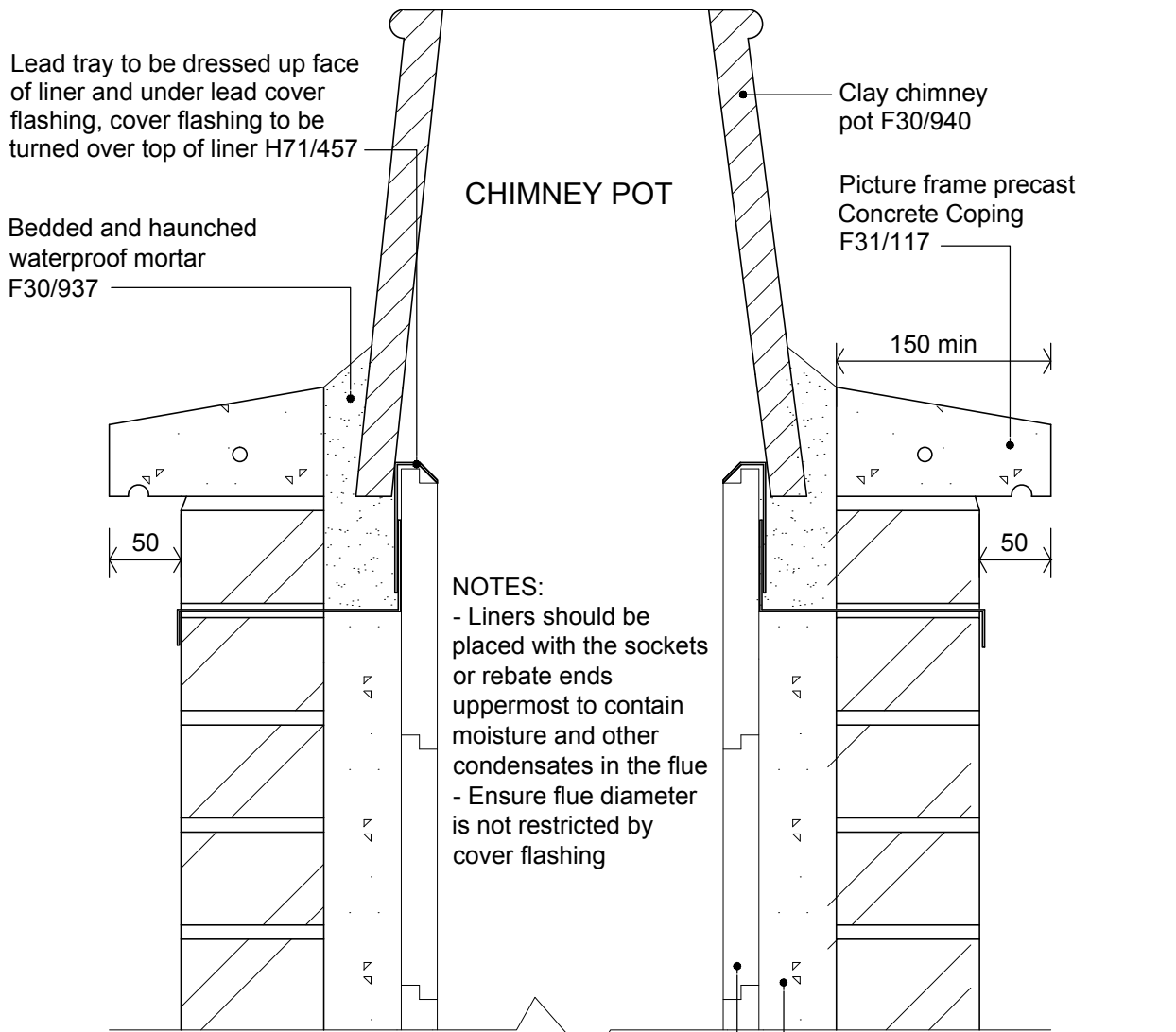

**NOTES:**  
 - Liners should be placed with the sockets or rebate ends uppermost to contain moisture and other condensates in the flue  
 - Ensure flue diameter is not restricted by cover flashing

**SECTION THROUGH CHIMNEY STACK (1:5)**

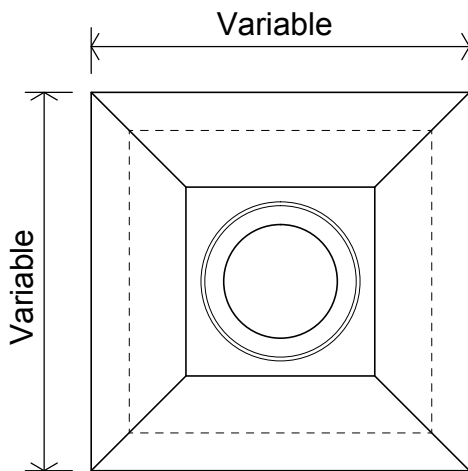

**PLAN OF CHIMNEY STACK (1:10)**

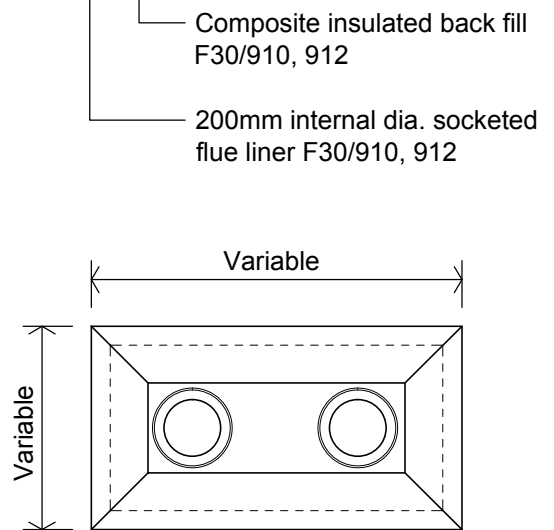

**PLAN OF DOUBLE FLUE STACK (1:20)**

SEE DETAIL A(04.11)01 FOR CHIMNEY / ROOF JUNCTION

SPECIFICATION REFERENCE: F31/117



**TITLE**  
 BRICK FLUE single & double  
 PICTURE FRAME  
 STACK COPING  
 PLANS AND SECTION

<b>DRAWN BY</b> P&S	<b>SCALE</b> 1:5, 10, 20	<b>DATE</b> Apr 91
<b>DRAWING NO.</b>	A(03.12)05	
<b>REV NO. &amp; DATE</b>	(6) 07/16	
<b>REV NOTE:</b> Reference to A(04.11)01		



© NIHE 2017 DRAWINGS NOT TO BE SCALED DUE TO PRINTING DISTORTION

\* This NIHE produced detail has been examined by The Building Control N.I. Standards Panel and has been considered reasonable in its interpretation of the relevant requirements of the Building Regulation NI 2012. There is no legal obligation for any Building Control department to adopt this recommendation & it is subject to revision in the event of changes to the legislation or other mitigating circumstances.

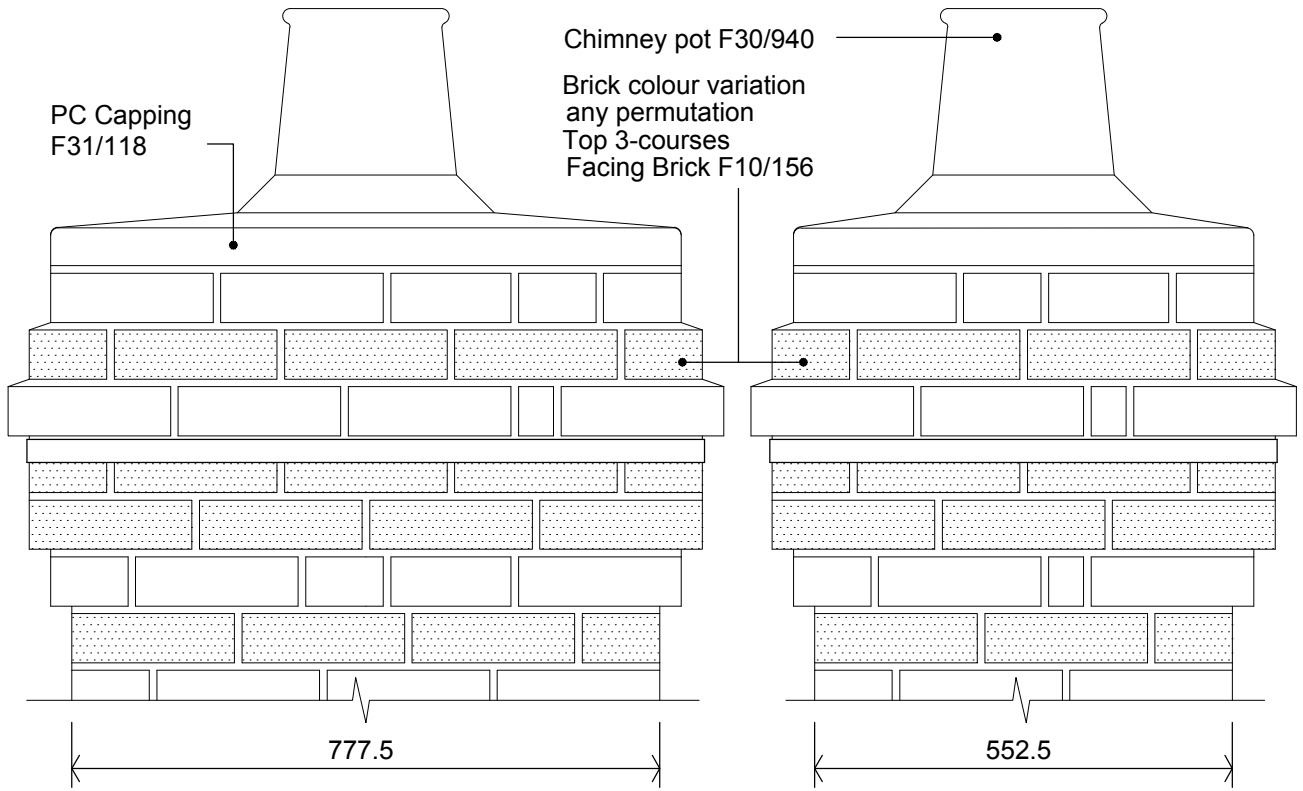

ELEVATIONS

NB: Corbelling of external brick not to exceed 1/3rd thickness of brick as BS 5628 pt.3

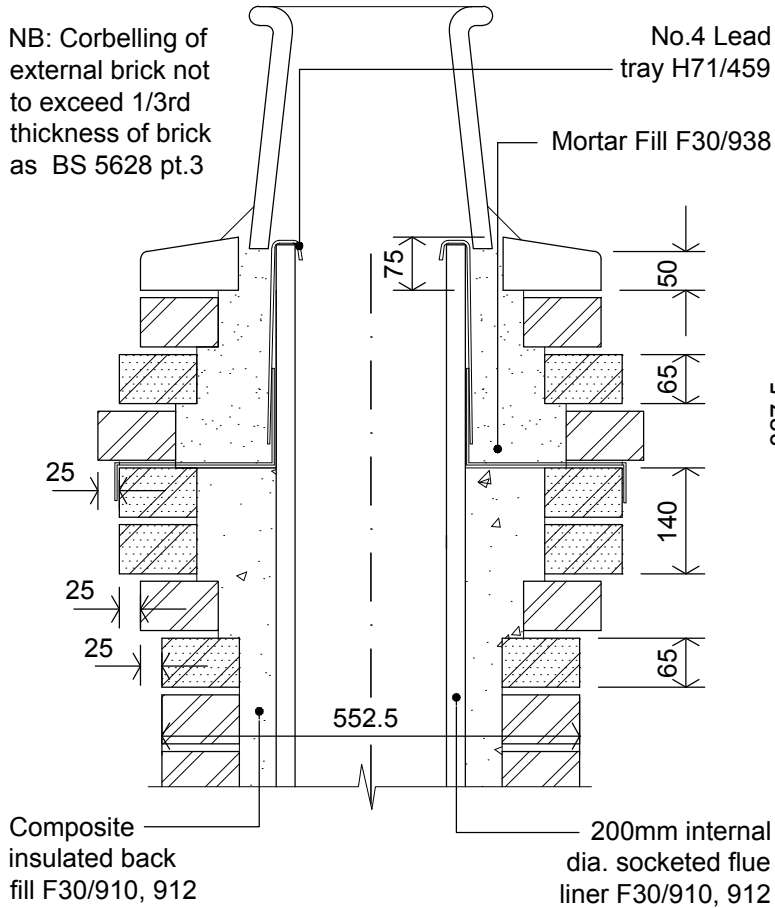

SECTION

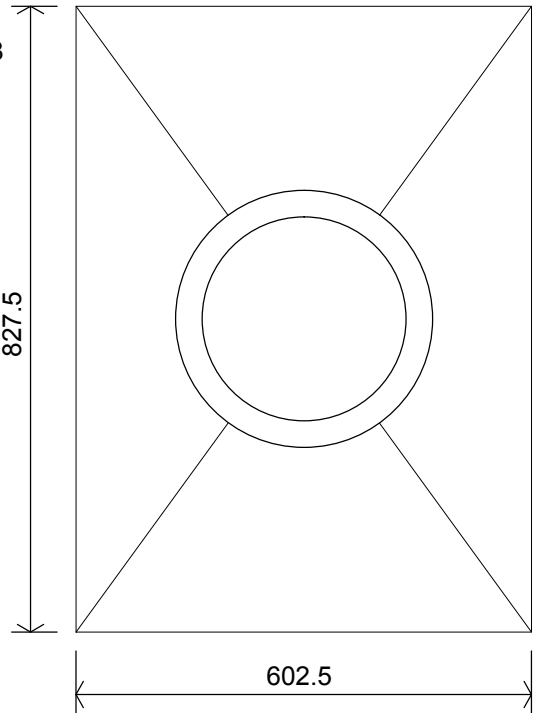

PLAN

SEE DETAIL A(04.11)01 FOR CHIMNEY / ROOF JUNCTION

SPECIFICATION REFERENCE: F31/118

**Housing Executive**

**BCNI Standards Panel Agreed \***

TITLE  
TYPICAL CORBELLED  
BRICK CHIMNEY  
COPING DETAIL  
ELEVATIONS, PLAN  
AND SECTION

DRAWN BY <b>P&amp;S</b>	SCALE <b>1:10</b>	DATE <b>Apr 91</b>
DRAWING NO.	<b>A(03.12)06</b>	
REV NO. & DATE	<b>(5) 07/16</b>	
REV NOTE: <b>Reference to A(04.11)01</b>		



\* This NIHE produced detail has been examined by The Building Control N.I. Standards Panel and has been considered reasonable in its interpretation of the relevant requirements of the Building Regulation NI 2012. There is no legal obligation for any Building Control department to adopt this recommendation & it is subject to revision in the event of changes to the legislation or other mitigating circumstances.

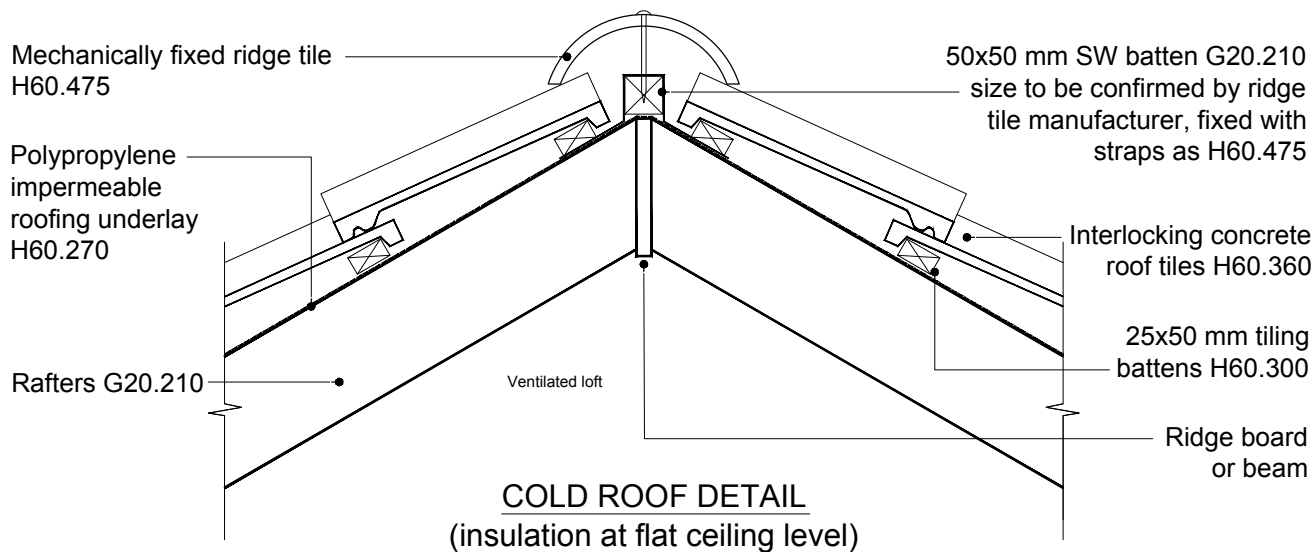
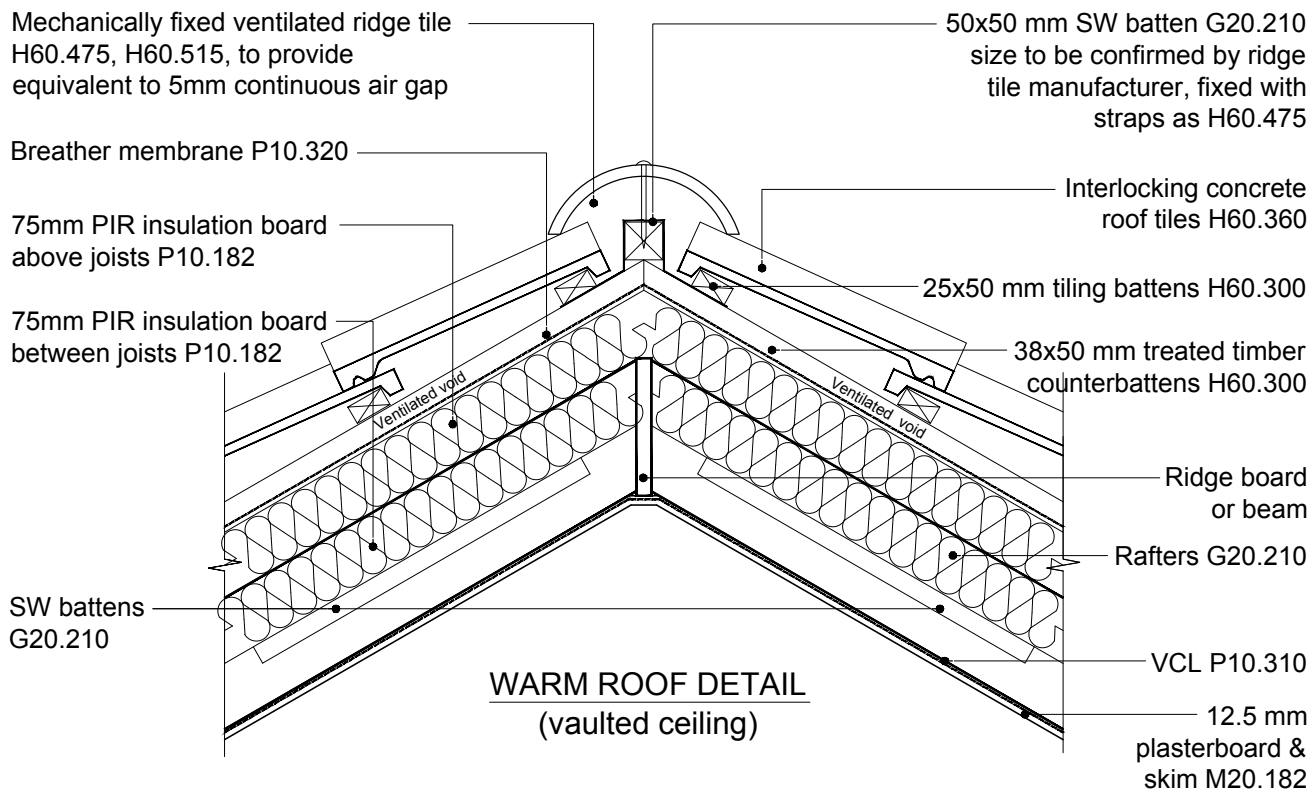

**Notes:**

- Rafter sizes to comply with current Building Regulations.
- All tiles to be mechanically fixed in accordance with BS 5534 and manufacturer's site specific instructions.
- Perimeter tiles to have a minimum of 2 no. fixings.
- Tiling battens and counter battens to comply with BS 5534. Gauge to be determined by tile manufacturer.
- Breather membrane to comply with BS 5534 and to be suitable for site specific conditions and batten gauge.
- All verges and hips to be mechanically fixed as H60 and in accordance with BS 5534.
- Roof to have a U-value not greater than 0.18 W/m<sup>2</sup>K
- Cold roofs require additional high-level ventilation, equivalent to 5mm continuous air gap, if the pitch is >35°, the span is >10m wide, or if the roof is a lean-to or monopitch.

**Housing Executive**

**BCNI Standards Panel Agreed \***

TITLE

**MECHANICALLY FIXED RIDGE TILE warm & cold roof**

DRAWN BY  
**P&S**

SCALE  
**1:10**

DATE  
**03/15**

DRAWING NO.

**A(04.10)07**

REV NO. & DATE

**(4) 11/16**

REV NOTE:

Updated spec clauses & notes



\* This NIHE produced detail has been examined by The Building Control N.I. Standards Panel and has been considered reasonable in its interpretation of the relevant requirements of the Building Regulation NI 2012. There is no legal obligation for any Building Control department to adopt this recommendation & it is subject to revision in the event of changes to the legislation or other mitigating circumstances.

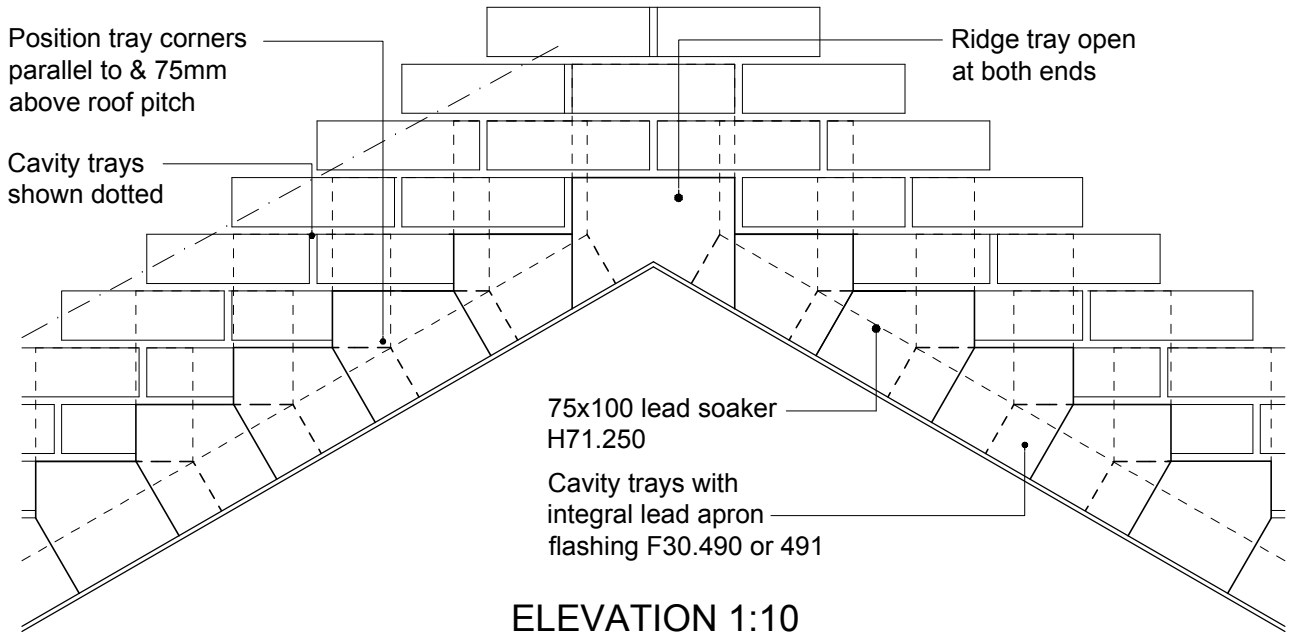

ELEVATION 1:10

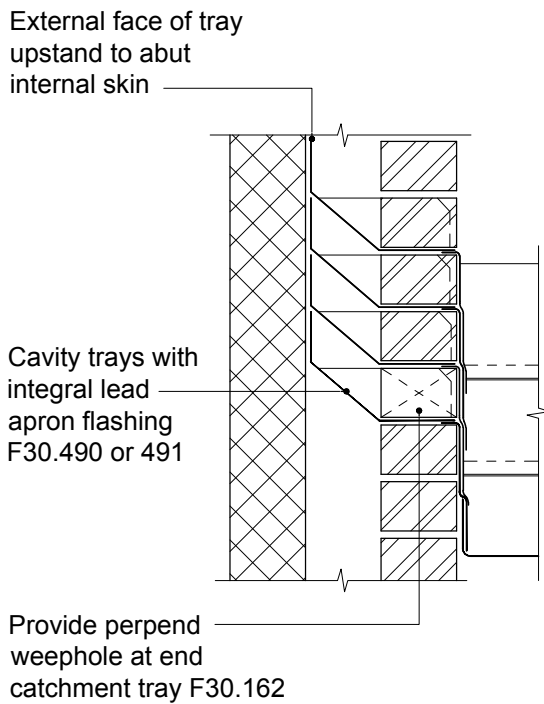

SECTION 1:10

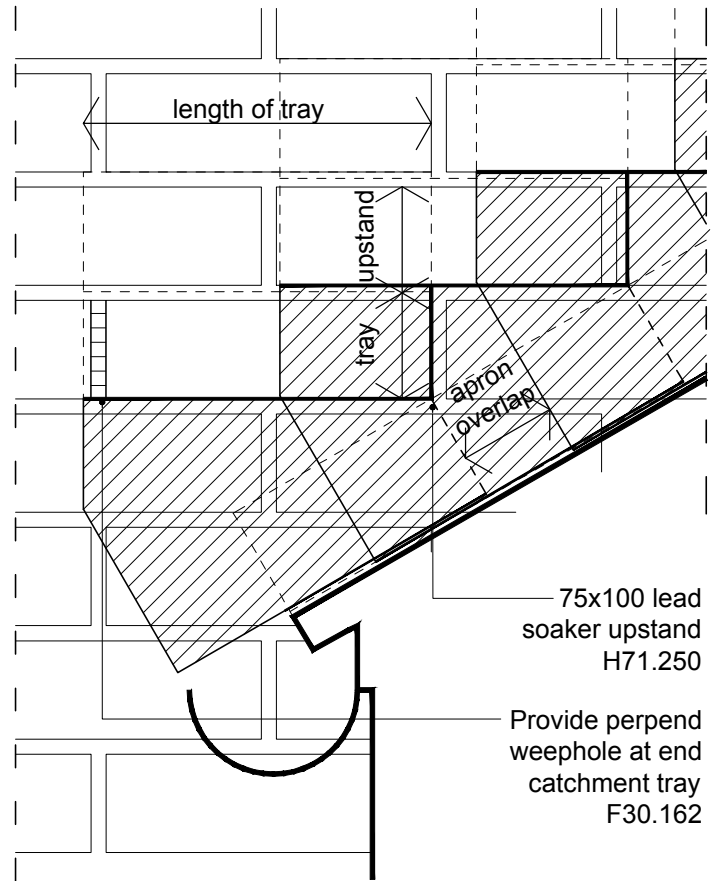

ELEVATION DETAIL 1:5

© NIHE 2017 DRAWINGS NOT TO BE SCALED DUE TO PRINTING DISTORTION

**Housing Executive**

*BCNI Standards Panel Agreed \**

TITLE

**ABUTMENT FLASHING DETAIL AT HIGH AND LOW DWELLINGS (SHEET 1)**

DRAWN BY <b>P&amp;S</b>	SCALE <b>1:5/1:10</b>	DATE <b>Apr 91</b>
DRAWING NO.	<b>A(04.11)04</b>	
REV NO. & DATE	<b>(4) 11/14</b>	
REV NOTE: Updated for Building Control		



\* This NIHE produced detail has been examined by The Building Control N.I. Standards Panel and has been considered reasonable in its interpretation of the relevant requirements of the Building Regulation NI 2012. There is no legal obligation for any Building Control department to adopt this recommendation & it is subject to revision in the event of changes to the legislation or other mitigating circumstances.

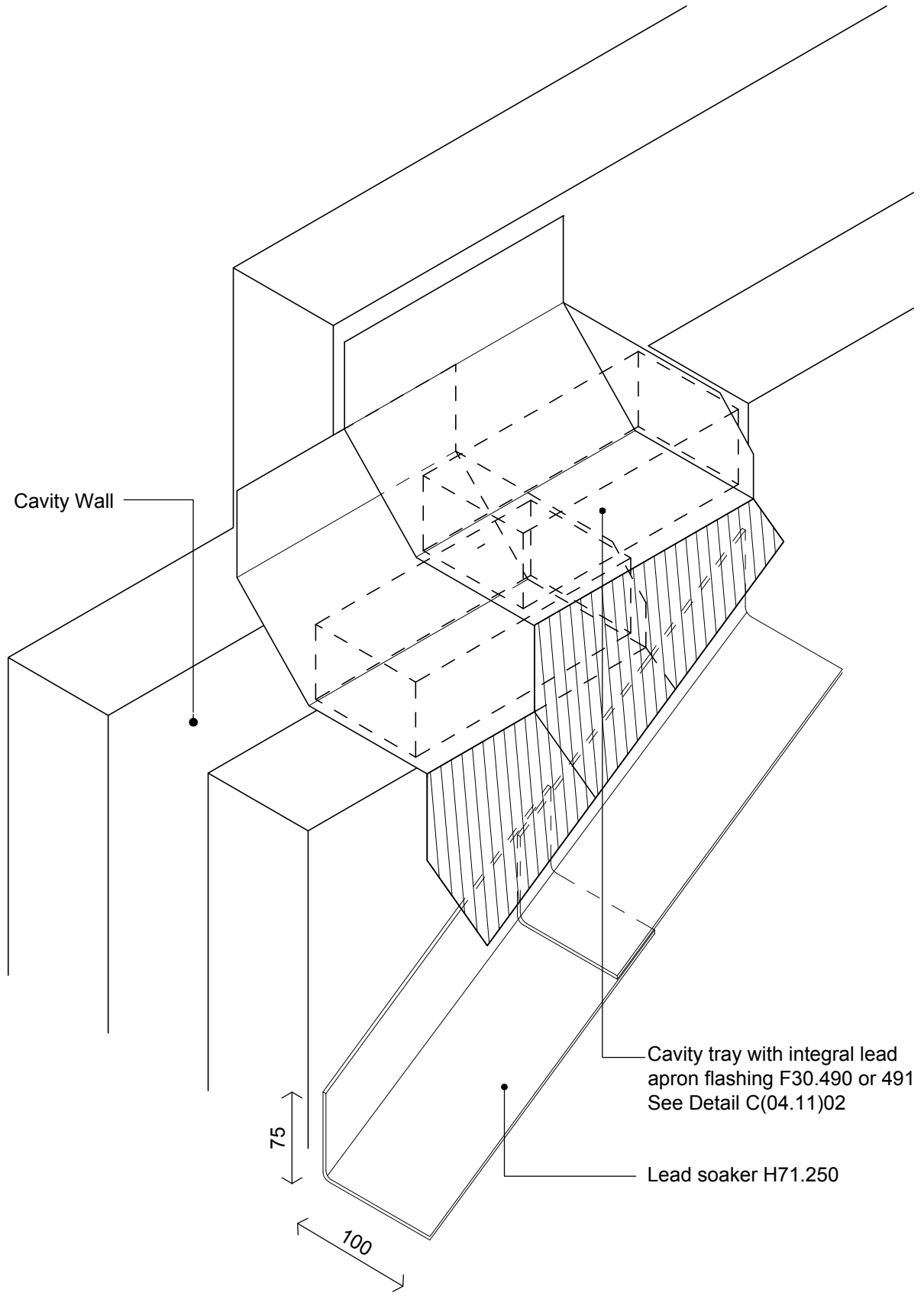

DRAWINGS NOT TO BE SCALED DUE TO PRINTING DISTORTION



**BCNI Standards  
Panel Agreed \***

TITLE  
**ABUTMENT FLASHING  
DETAIL AT HIGH AND  
LOW DWELLINGS  
(SHEET 2)**

DRAWN BY <b>P&amp;S</b>	SCALE <b>1:5</b>	DATE <b>Apr 91</b>
DRAWING NO.	<b>A(04.11)05</b>	
REV NO. & DATE	<b>(5) 11/14</b>	
REV NOTE: <b>Updated for Building Control</b>		

\* This NIHE produced detail has been examined by The Building Control N.I. Standards Panel and has been considered reasonable in its interpretation of the relevant requirements of the Building Regulation NI 2012. There is no legal obligation for any Building Control department to adopt this recommendation & it is subject to revision in the event of changes to the legislation or other mitigating circumstances.

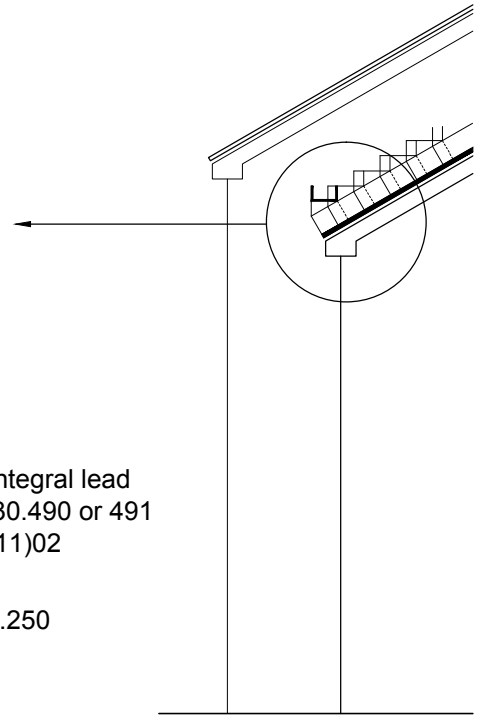
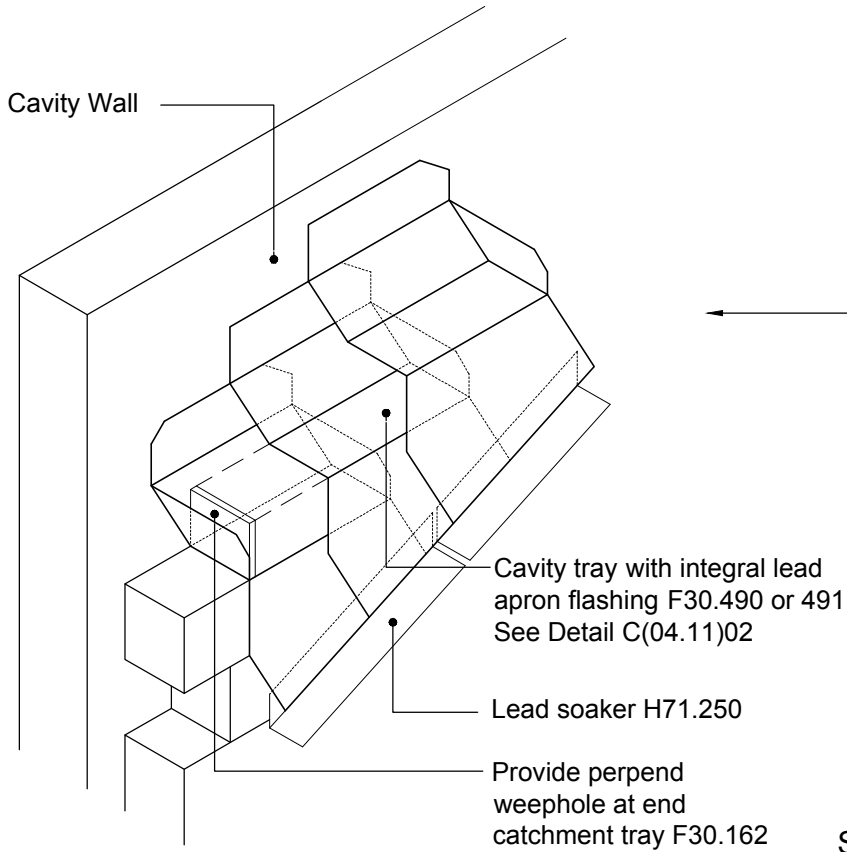

**STEPPED ABUTMENT**  
between buildings of  
different widths

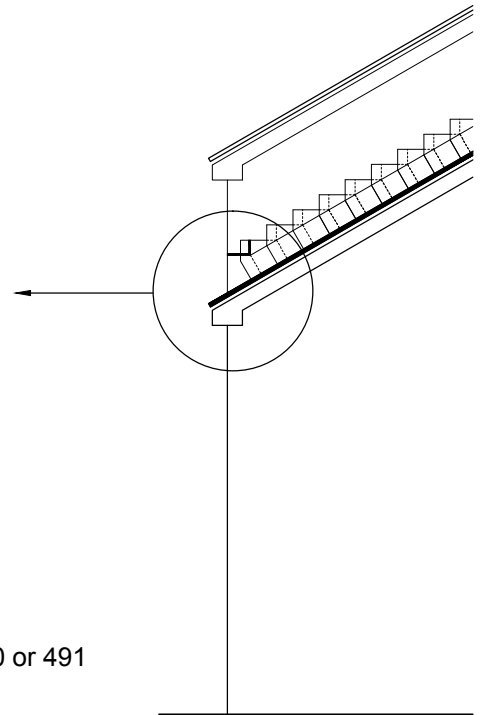
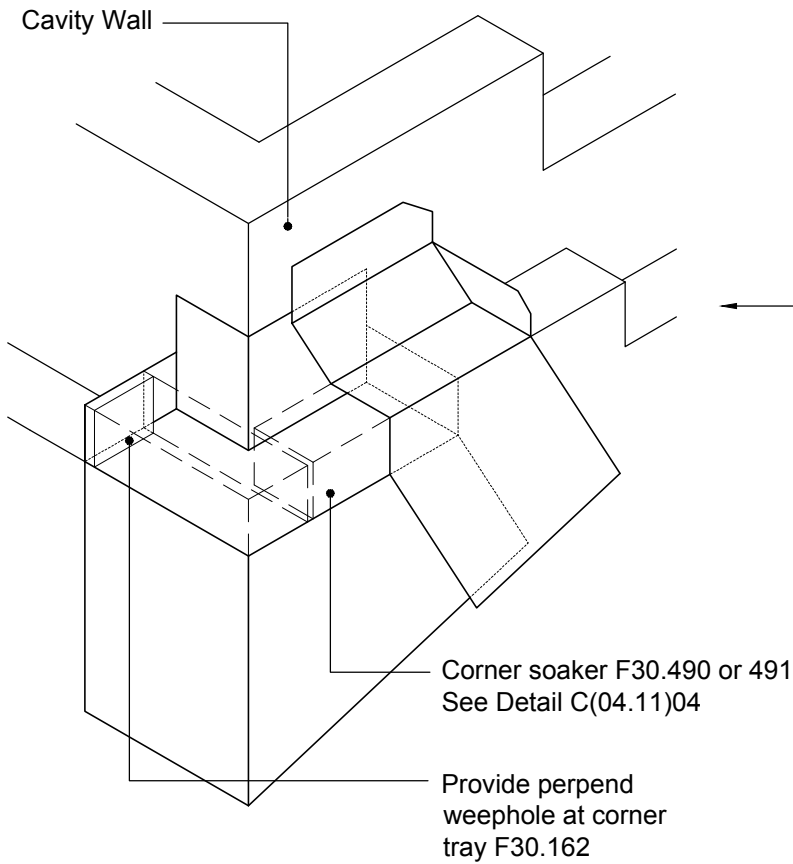

**STEPPED ABUTMENT**

© NIHE 2017  
DRAWINGS NOT TO BE SCALED DUE TO PRINTING DISTORTION



**BCNI Standards**  
**Panel Agreed \***

TITLE  
**FLASHING AT STEPPED  
ABUTMENTS**

DRAWN BY <b>P&amp;S</b>	SCALE <b>N.T.S.</b>	DATE <b>Apr 91</b>
DRAWING NO.	<b>A(04.11)06</b>	
REV NO. & DATE	<b>(5) 11/14</b>	
REV NOTE: Updated for Building Control		





\* This NIHE produced detail has been examined by The Building Control N.I. Standards Panel and has been considered reasonable in its interpretation of the relevant requirements of the Building Regulation NI 2012. There is no legal obligation for any Building Control department to adopt this recommendation & it is subject to revision in the event of changes to the legislation or other mitigating circumstances.

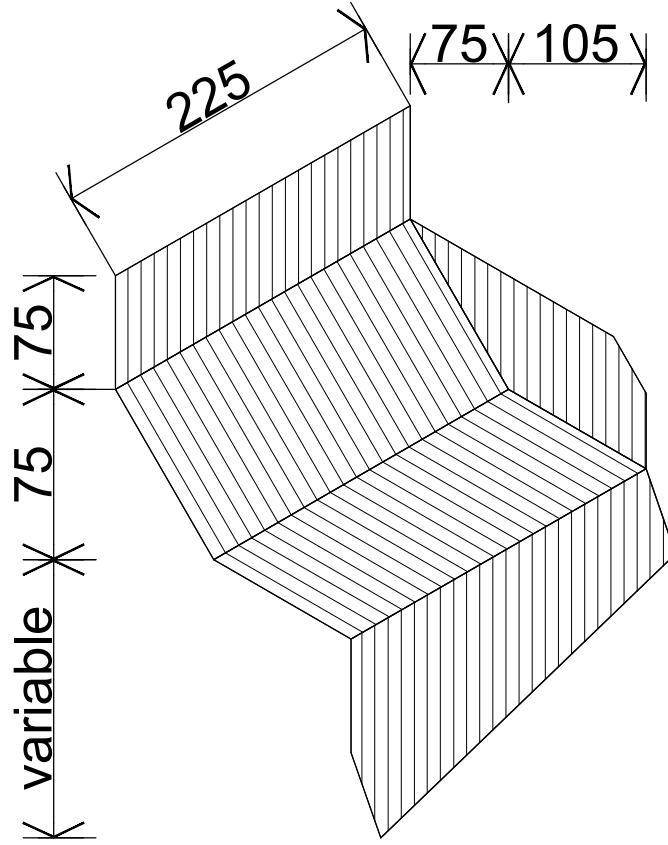

ISOMETRIC VIEW

SPECIFICATION REF: F30/490

**Housing**  
Executive

**BCNI Standards**  
**Panel Agreed \***

TITLE  
CAVITY TRAY  
(Lead-Tray  
or  
Plastic-with-Leaded-Apron)

DRAWN BY TJB	SCALE 1:5	DATE Oct 90
DRAWING NO.	C(04.11)02	
REV NO. & DATE	(2) 6/03	
REV NOTE:		



\* This NIHE produced detail has been examined by The Building Control N.I. Standards Panel and has been considered reasonable in its interpretation of the relevant requirements of the Building Regulation NI 2012. There is no legal obligation for any Building Control department to adopt this recommendation & it is subject to revision in the event of changes to the legislation or other mitigating circumstances.

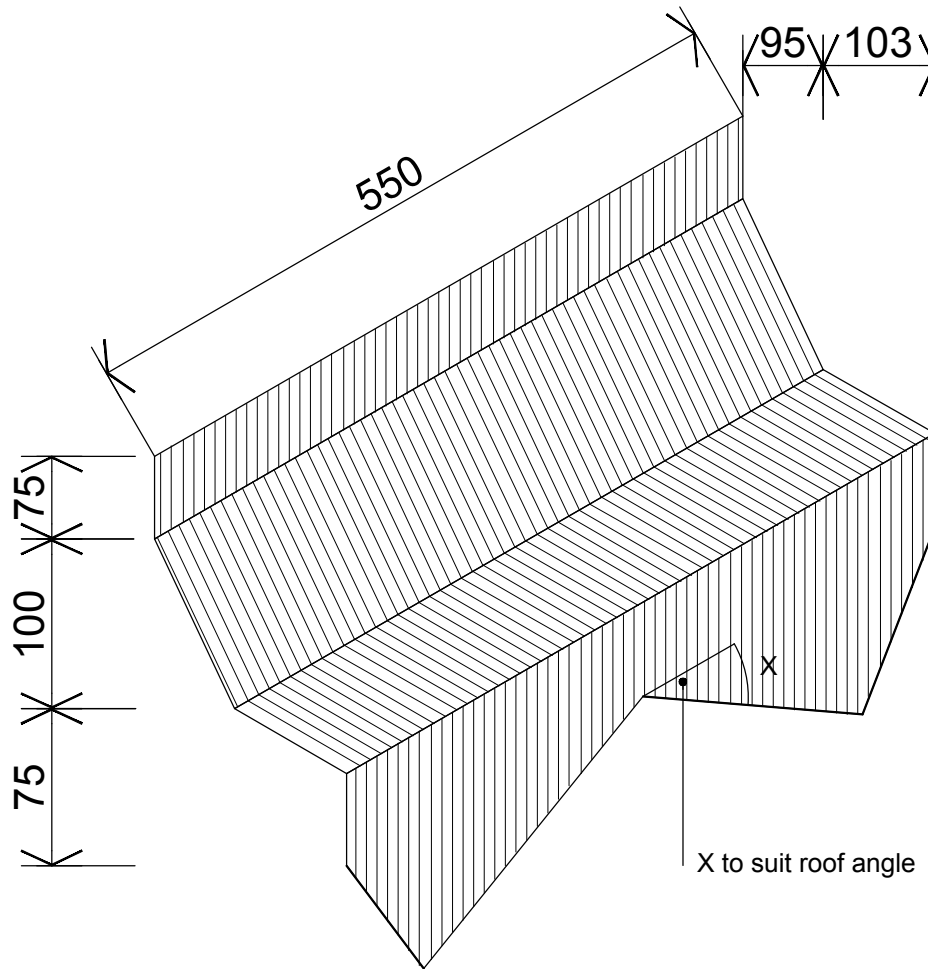

ISOMETRIC VIEW

SPECIFICATION REF: F30/490, 491

**Housing**  
Executive

BCNI Standards  
Panel Agreed \*

TITLE  
RIDGE CAVITY TRAY  
(Lead-Tray  
OR  
Plastic-with-Leaded-apron)

DRAWN BY TJB/CB	SCALE 1:5	DATE Oct 90
DRAWING NO.	C(04.11)03	
REV NO. & DATE	(2) 10/12	
REV NOTE: Updated to revised spec		



\* This NIHE produced detail has been examined by The Building Control N.I. Standards Panel and has been considered reasonable in it's interpretation of the relevant requirements of the Building Regulation NI 2012. There is no legal obligation for any Building Control department to adopt this recommendation & it is subject to revision in the event of changes to the legislation or other mitigating circumstances.

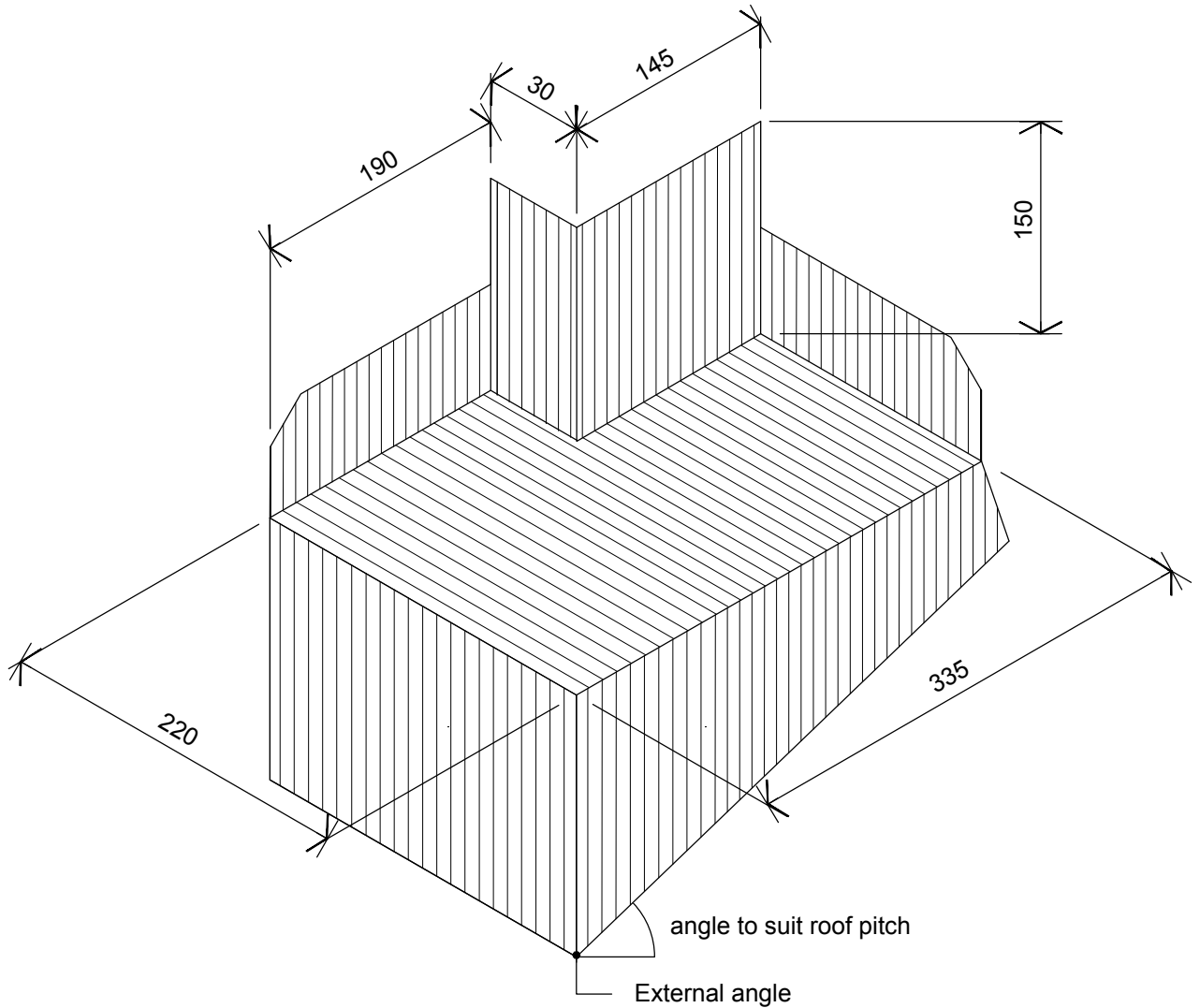

**ISOMETRIC VIEW**

NOTE: Provide perpend weep holes at lowest cavity tray.

SPECIFICATION REF: F30/490, 491



TITLE	EAVES CAVITY TRAY (Lead OR Plastic-with-Leaded-apron)	
-------	--	--

DRAWN BY	SCALE	DATE
TJB/CB	1:5	Oct 90
DRAWING NO.	C(04.11)04	
REV NO. & DATE	(3) 10/12	
REV NOTE:	Updated to revised spec	



\* This NIHE produced detail has been examined by The Building Control N.I. Standards Panel and has been considered reasonable in its interpretation of the relevant requirements of the Building Regulation NI 2012. There is no legal obligation for any Building Control department to adopt this recommendation & it is subject to revision in the event of changes to the legislation or other mitigating circumstances.

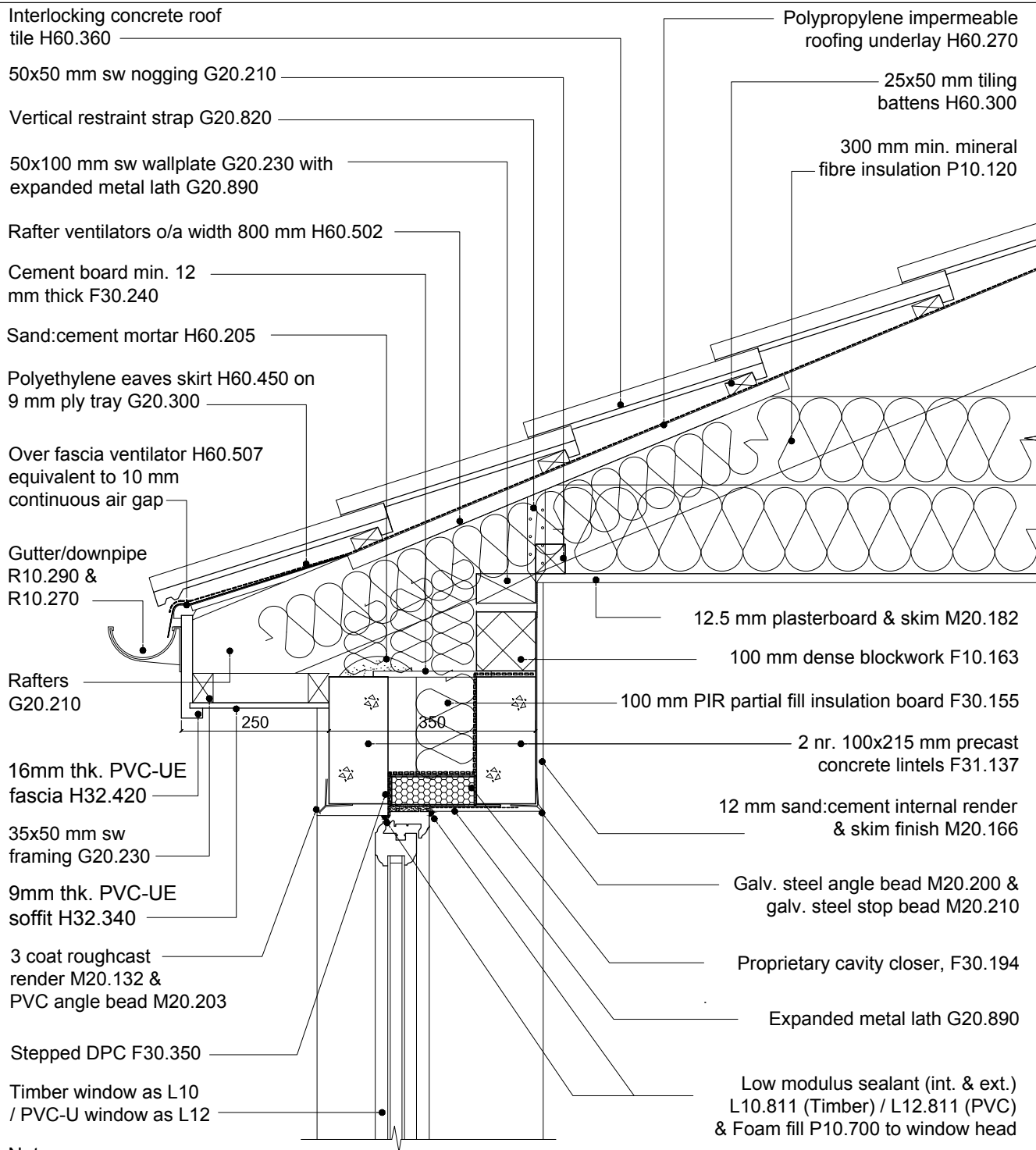

**Notes:**

- Rafter sizes to comply with current Building Regulations.
- Roof to have a U-value not greater than 0.16 W/m<sup>2</sup>K and walls not greater than 0.28 W/m<sup>2</sup>K.
- All tiling, including verges and hips, to be mechanically fixed in accordance with current version of BS 5534 and manufacturer's site specific instructions. Perimeter tiles to have a minimum of 2 no. fixings.
- Underlay, tiling battens & counterbattens to comply with current version of BS 5534. Spacing of battens to be determined by tile manufacturer.
- Proprietary cavity closer to provide 30 minutes fire resistance and thermal conductivity no greater than 0.038W/mK, F30.194.
- Stainless steel wall ties as F30.214 fixed and staggered at 900mm horizontal & 450mm vertically.
- Windows fitted as per NIHE Codes of Practice L10 (Timber) & L12 (PVC).
- Where a facing brick outer leaf is preferred apply clause F10.151(general brickwork clause to be completed by the Designer). See Detail A(02.11)18 for insulated steel lintel.

**Housing Executive**

**BCNI Standards Panel Agreed \***

TITLE

**TYPICAL EAVES DETAIL  
22.5° PITCH**

**(350mm cavity wall)**

DRAWN BY  
**P&S**

SCALE  
**1:10**

DATE  
**Apr 91**

DRAWING NO.

**A(04.12)02**

REV NO. & DATE

**(8) 04/17**

REV NOTE: Cavity closer location, PVC fascia & soffit



\* This NIHE produced detail has been examined by The Building Control N.I. Standards Panel and has been considered reasonable in its interpretation of the relevant requirements of the Building Regulation NI 2012. There is no legal obligation for any Building Control department to adopt this recommendation & it is subject to revision in the event of changes to the legislation or other mitigating circumstances.

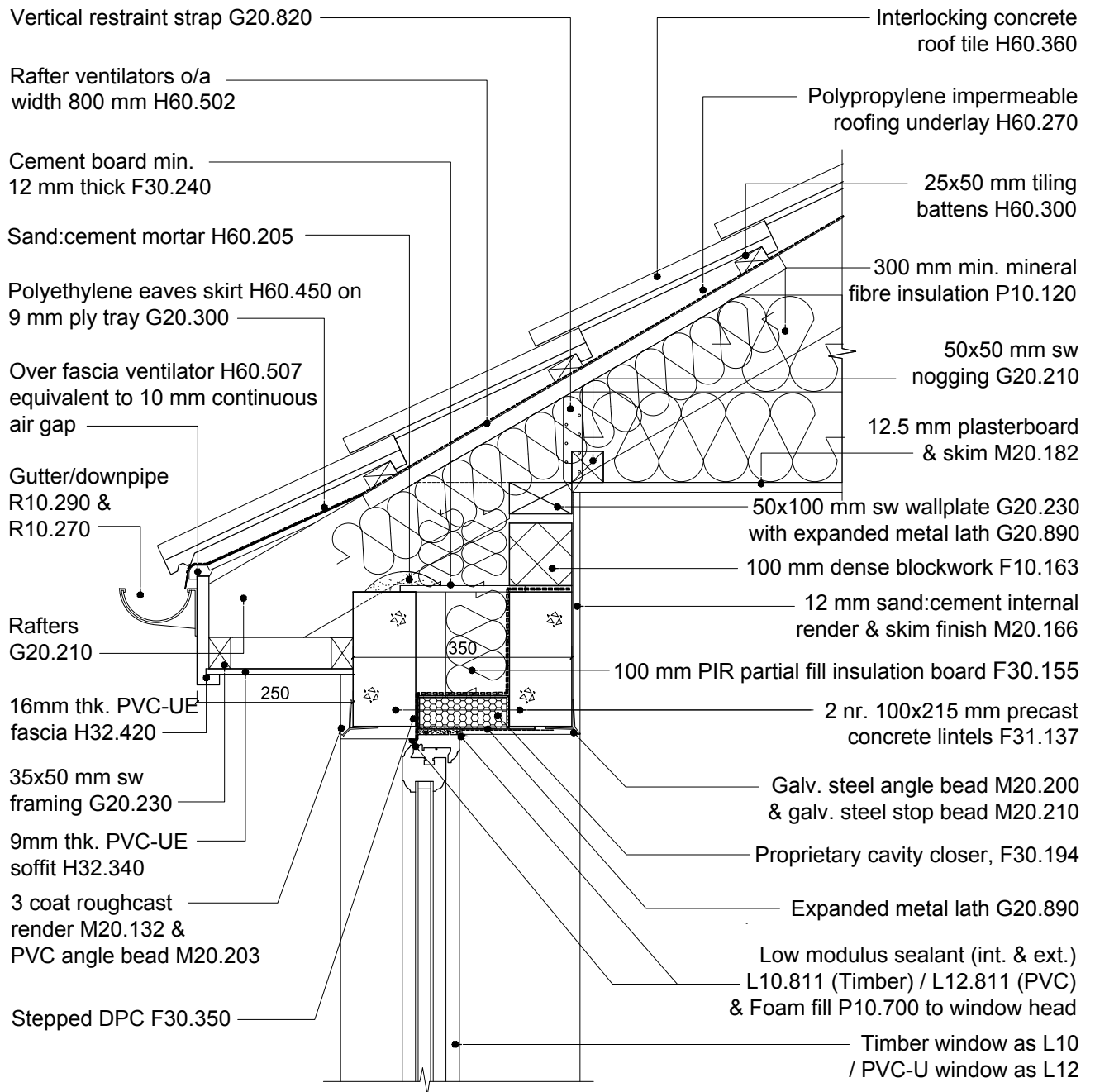

**Notes:**

- Rafter sizes to comply with current Building Regulations.
- Roof to have a U-value not greater than 0.16 W/m<sup>2</sup>K and walls not greater than 0.28 W/m<sup>2</sup>K.
- All tiling, including verges and hips, to be mechanically fixed in accordance with current version of BS 5534 and manufacturer's site specific instructions. Perimeter tiles to have a minimum of 2 no. fixings.
- Underlay, tiling battens & counterbattens to comply with current version of BS 5534. Spacing of battens to be determined by tile manufacturer.
- Proprietary cavity closer to provide 30 minutes fire resistance and thermal conductivity no greater than 0.038W/mK, F30.194.
- Stainless steel wall ties as F30.214 fixed and staggered at 900mm horizontal & 450mm vertically.
- Windows fitted as per NIHE Codes of Practice L10 (Timber) & L12 (PVC).
- Where a facing brick outer leaf is preferred apply clause F10.151(general brickwork clause to be completed by the Designer). See Detail A(02.11)18 for insulated steel lintel.

**Housing Executive**

**BCNI Standards Panel Agreed \***

TITLE

**TYPICAL EAVES DETAIL  
30° PITCH**

DRAWN BY  
**P&S**

SCALE  
**1:10**

DATE  
**Apr 91**

DRAWING NO.

**A(04.12)03**

REV NO. & DATE

**(12) 04/17**

REV NOTE: Cavity closer location, PVC fascia & soffit



\* This NIHE produced detail has been examined by The Building Control N.I. Standards Panel and has been considered reasonable in its interpretation of the relevant requirements of the Building Regulation NI 2012. There is no legal obligation for any Building Control department to adopt this recommendation & it is subject to revision in the event of changes to the legislation or other mitigating circumstances.

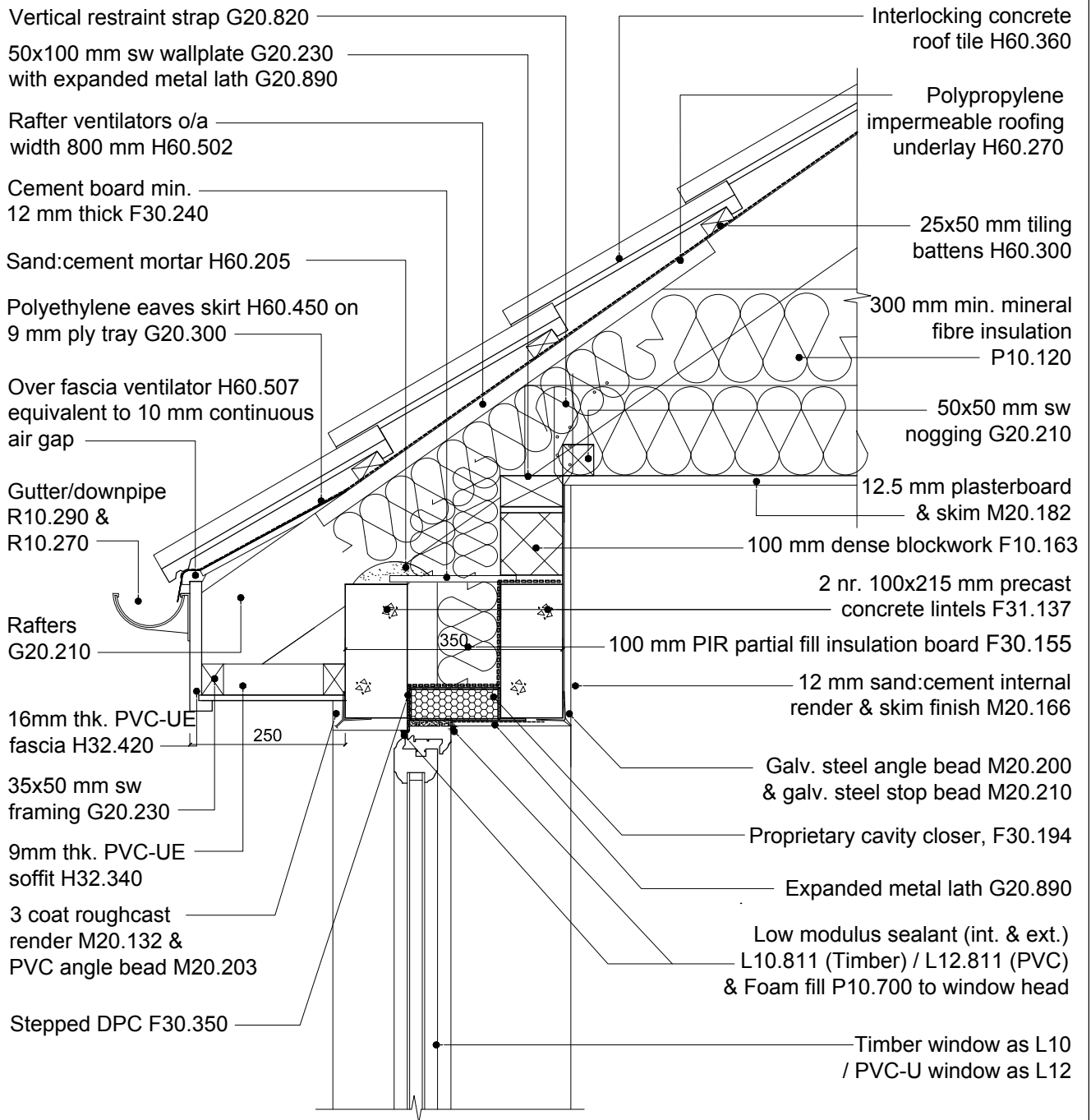

**Notes:**

- Rafter sizes to comply with current Building Regulations.
- Roof to have a U-value not greater than 0.16 W/m<sup>2</sup>K and walls not greater than 0.28 W/m<sup>2</sup>K.
- All tiling, including verges and hips, to be mechanically fixed in accordance with current version of BS 5534 and manufacturer's site specific instructions. Perimeter tiles to have a minimum of 2 no. fixings.
- Underlay, tiling battens & counterbattens to comply with current version of BS 5534. Spacing of battens to be determined by tile manufacturer.
- Proprietary cavity closer to provide 30 minutes fire resistance and thermal conductivity no greater than 0.038W/mK, F30.194.
- Stainless steel wall ties as F30.214 fixed and staggered at 900mm horizontal & 450mm vertically.
- Windows fitted as per NIHE Codes of Practice L10 (Timber) & L12 (PVC).
- Where a facing brick outer leaf is preferred apply clause F10.151 (general brickwork clause to be completed by the Designer). See Detail A(02.11)18 for insulated steel lintel.

**Housing Executive**

**BCNI Standards Panel Agreed\***

TITLE

TYPICAL EAVES DETAIL  
35° PITCH

(350mm cavity wall)

DRAWN BY  
P&S

SCALE  
1:10

DATE  
Apr 91

DRAWING NO.

A(04.12)04

REV NO. & DATE

(8) 04/17

REV NOTE: Cavity closer location, PVC fascia & soffit



\* This NIHE produced detail has been examined by The Building Control N.I. Standards Panel and has been considered reasonable in its interpretation of the relevant requirements of the Building Regulation NI 2012. There is no legal obligation for any Building Control department to adopt this recommendation & it is subject to revision in the event of changes to the legislation or other mitigating circumstances.

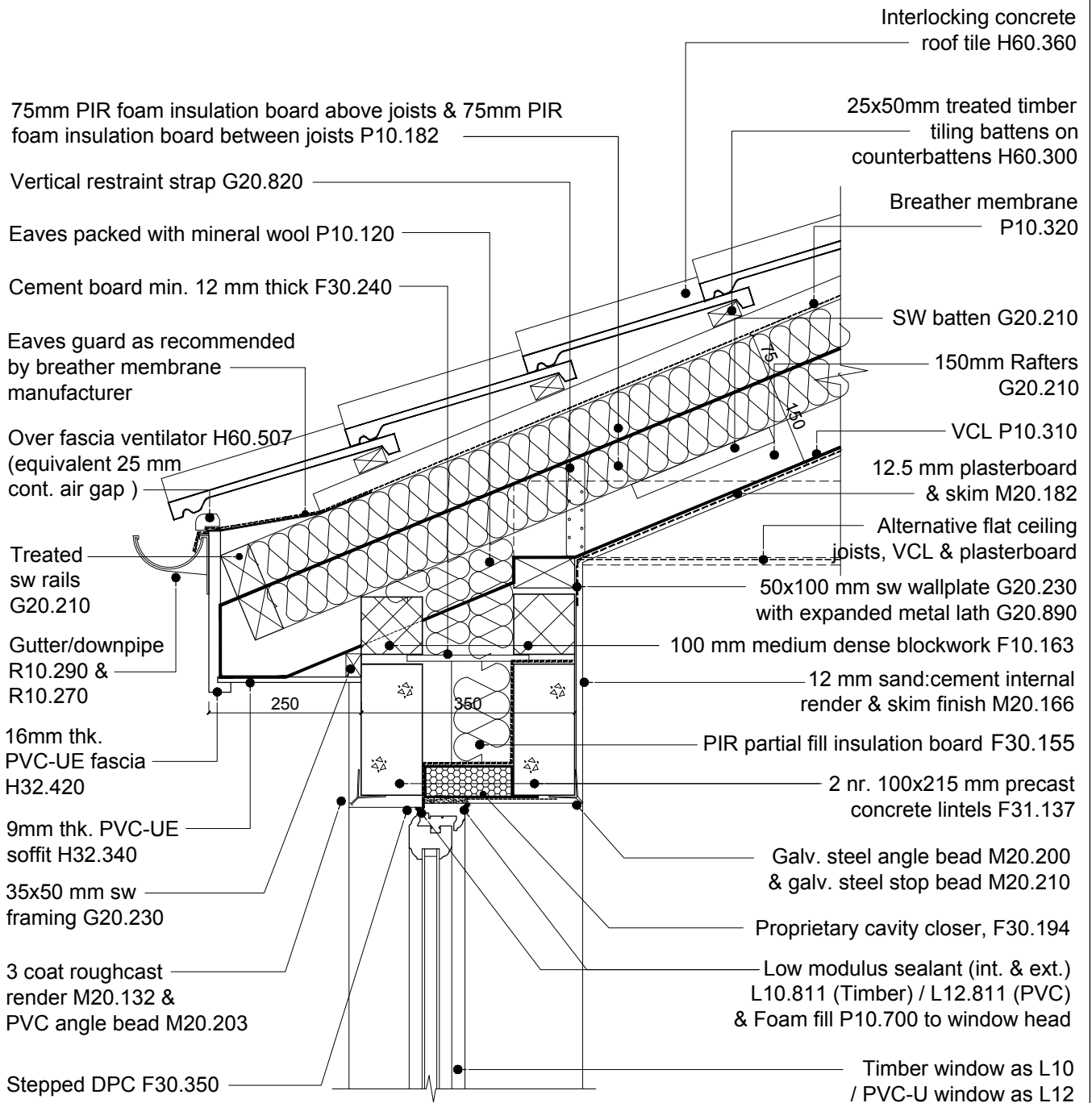

**Notes:**

- Rafter sizes to comply with current Building Regulations.
- Roof to have a U-value not greater than 0.18 W/m<sup>2</sup>K and walls not greater than 0.28 W/m<sup>2</sup>K.
- All tiling, including verges and hips, to be mechanically fixed in accordance with current version of BS 5534 and manufacturer's site specific instructions. Perimeter tiles to have a minimum of 2 no. fixings.
- Breather membrane, tiling battens & counterbattens to comply with current version of BS 5534. Spacing of battens to be determined by tile manufacturer.
- SW timber battens side-fixed to rafters to hold roof insulation boards in place.
- Stainless steel wall ties as F30.214 fixed and staggered at 900mm horizontal & 450mm vertically.
- Windows fitted as per NIHE Codes of Practice L10 (Timber) & L12 (PVC).
- Where a facing brick outer leaf is preferred apply clause F10.151 (general brickwork clause to be completed by the Designer). See Detail A(02.11)18 for insulated steel lintel.



TITLE  
**WARM ROOF  
EAVES DETAIL  
22.5° PITCH**

DRAWN BY <b>P&amp;S</b>	SCALE <b>1:10</b>	DATE <b>Jan '15</b>
DRAWING NO.	<b>A(04.12)08</b>	
REV NO. & DATE	<b>(1) 07/16</b>	
REV NOTE: <b>Updated for Building Control</b>		



© NIHE 2017  
DRAWINGS NOT TO BE SCALED DUE TO PRINTING DISTORTION

\* This NIHE produced detail has been examined by The Building Control N.I. Standards Panel and has been considered reasonable in its interpretation of the relevant requirements of the Building Regulation NI 2012. There is no legal obligation for any Building Control department to adopt this recommendation & it is subject to revision in the event of changes to the legislation or other mitigating circumstances.

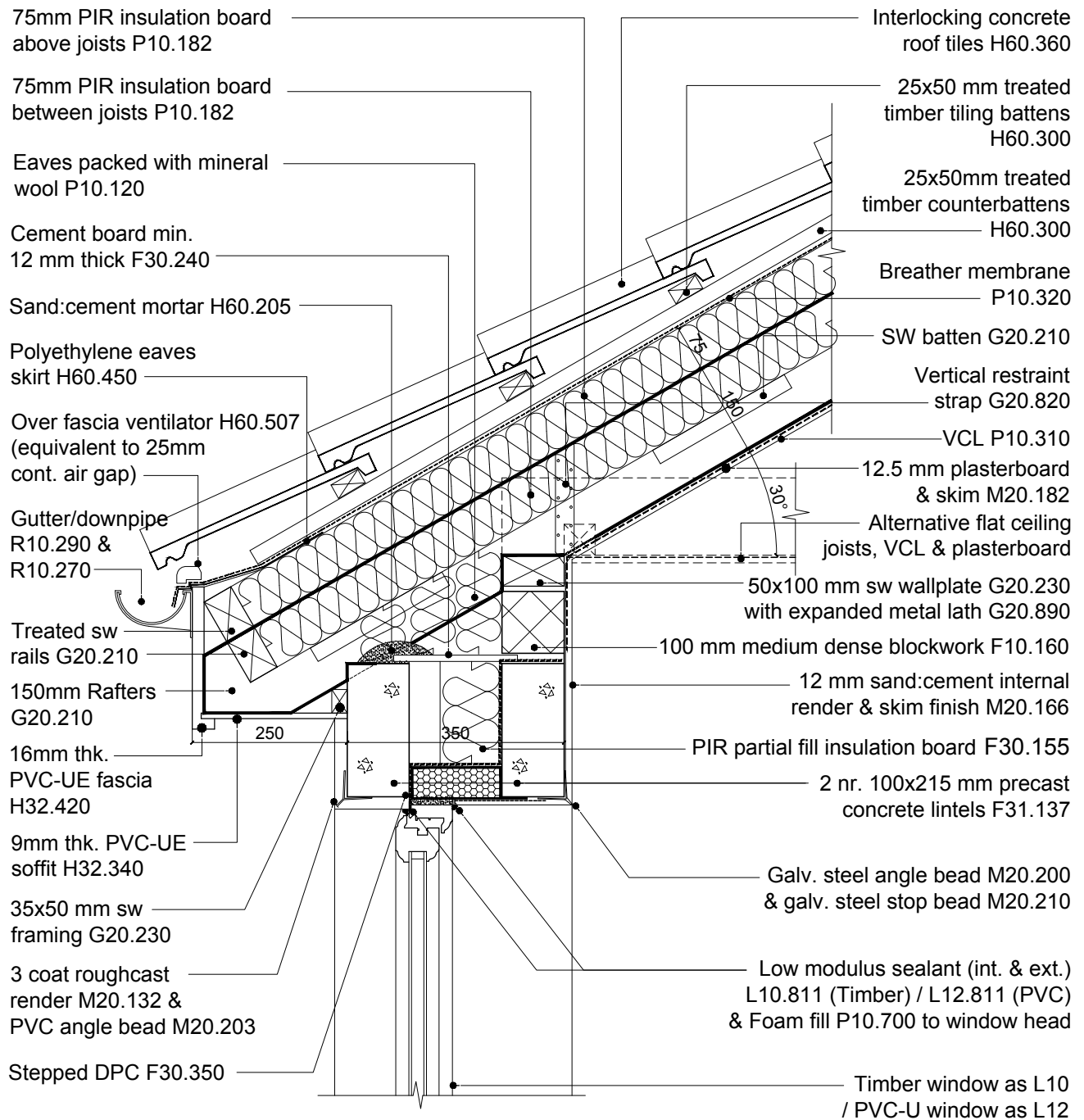

**Notes:**

- Rafter sizes to comply with current Building Regulations.
- Roof to have a U-value not greater than 0.18 W/m<sup>2</sup>K and walls not greater than 0.28 W/m<sup>2</sup>K.
- All tiling, including verges and hips, to be mechanically fixed in accordance with current version of BS 5534 and manufacturer's site specific instructions. Perimeter tiles to have a minimum of 2 no. fixings.
- Breather membrane, tiling battens & counterbattens to comply with current version of BS 5534. Spacing of battens to be determined by tile manufacturer.
- SW timber battens side-fixed to rafters to hold insulation board in place.
- Stainless steel wall ties as F30.214 fixed and staggered at 900mm horizontal & 450mm vertically.
- Windows fitted as per NIHE Codes of Practice L10 (Timber) & L12 (PVC).
- Where a facing brick outer leaf is preferred apply clause F10.151 (general brickwork clause to be completed by the Designer). See Detail A(02.11)18 for insulated steel lintel.

**Housing Executive**

**BCNI Standards Panel Agreed \***

TITLE

**WARM ROOF EAVES DETAIL  
30° PITCH**

DRAWN BY  
**P&S**

SCALE  
**1:10**

DATE  
**Jan '15**

DRAWING NO.

**A(04.12)09**

REV NO. & DATE

**(1) 07/16**

REV NOTE:

**Updated for Building Control**





\* This NIHE produced detail has been examined by The Building Control N.I. Standards Panel and has been considered reasonable in its interpretation of the relevant requirements of the Building Regulation NI 2012. There is no legal obligation for any Building Control department to adopt this recommendation & it is subject to revision in the event of changes to the legislation or other mitigating circumstances.

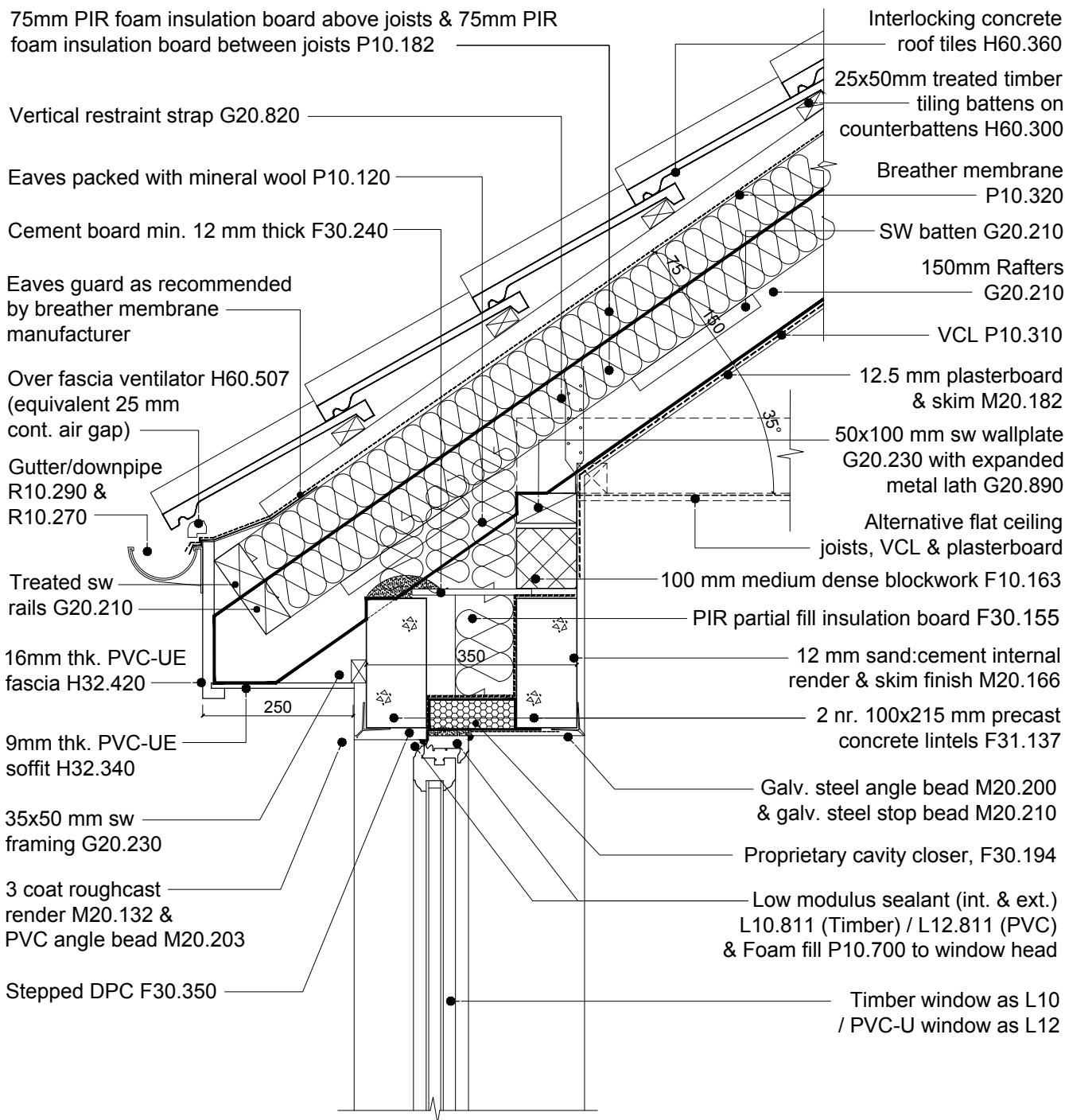

**Notes:**

- Rafter sizes to comply with current Building Regulations.
- Roof to have a U-value not greater than 0.18 W/m<sup>2</sup>K and walls not greater than 0.28 W/m<sup>2</sup>K.
- All tiling, including verges and hips, to be mechanically fixed in accordance with current version of BS 5534 and manufacturer's site specific instructions. Perimeter tiles to have a minimum of 2 no. fixings.
- Breather membrane, tiling battens & counterbattens to comply with current version of BS 5534. Spacing of battens to be determined by tile manufacturer.
- SW timber battens side-fixed to rafters to hold insulation board in place.
- Stainless steel wall ties as F30.214 fixed and staggered at 900mm horizontal & 450mm vertically.
- Windows fitted as per NIHE Codes of Practice L10 (Timber) & L12 (PVC).
- Where a facing brick outer leaf is preferred apply clause F10.151 (general brickwork clause to be completed by the Designer). See Detail A(02.11)18 for insulated steel lintel.

**Housing Executive**

**BCNI Standards Panel Agreed \***

TITLE

WARM ROOF  
EAVES DETAIL  
35° PITCH

DRAWN BY  
P&S

SCALE  
1:10

DATE  
Jan '15

DRAWING NO.

A(04.12)10

REV NO. & DATE

(2) 04/17

REV NOTE:

Cavity closer location



\* This NIHE produced detail has been examined by The Building Control N.I. Standards Panel and has been considered reasonable in its interpretation of the relevant requirements of the Building Regulation NI 2012. There is no legal obligation for any Building Control department to adopt this recommendation & it is subject to revision in the event of changes to the legislation or other mitigating circumstances.

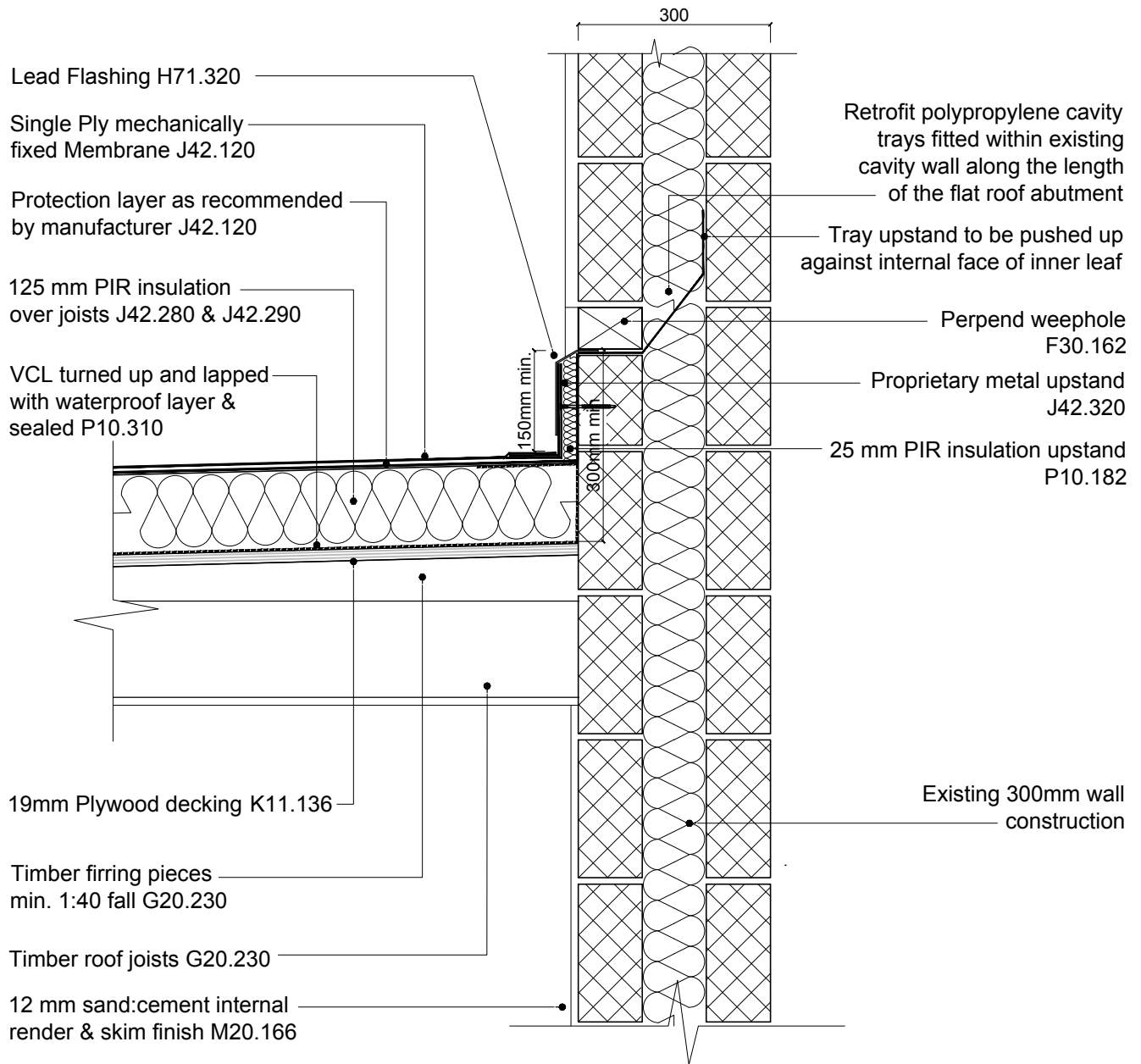

**Notes:**

- When fitting cavity trays to existing wall ensure to neatly replace or refill any displaced wall insulation.
- Ensure the top of the wall is level and the wall insulation is taken up level with it.
- Fix plasterboard to ceiling before plastering wall and seal all gaps between ceiling and masonry with low-modulus sealant Z22.115.
- Roof timber sizes to comply with current Building Regulations.
- Roof to have a U-value not greater than 0.18 W/m<sup>2</sup>K and walls not greater than 0.28 W/m<sup>2</sup>K.
- Roof to have a fall of no less than 1 in 40, unless otherwise recommended by manufacturer.
- Stainless steel wall ties as F30.214 fixed and staggered at 900mm horizontal & 450mm vertically.
- Windows fitted as per NIHE Codes of Practice L10 (Timber) & L12 (PVC).
- Where a facing brick outer leaf is preferred apply clause F10.151 (general brickwork clause to be completed by the Designer). See Details A(02.11)06 & 18 for insulated steel lintels.

© NIHE 2017  
DRAWINGS NOT TO BE SCALED DUE TO PRINTING DISTORTION



TITLE	DRAWN BY	SCALE	DATE
WARM FLAT ROOF  Abutment Detail	P&S	1:10	Dec '16
	DRAWING NO.	A(04.12)12	
	REV NO. & DATE		
	REV NOTE:		

DRAWN BY		SCALE	DATE
P&S		1:10	Dec '16
DRAWING NO.		A(04.12)12	
REV NO. & DATE			
REV NOTE:			



\* This NIHE produced detail has been examined by The Building Control N.I. Standards Panel and has been considered reasonable in its interpretation of the relevant requirements of the Building Regulation NI 2012. There is no legal obligation for any Building Control department to adopt this recommendation & it is subject to revision in the event of changes to the legislation or other mitigating circumstances.

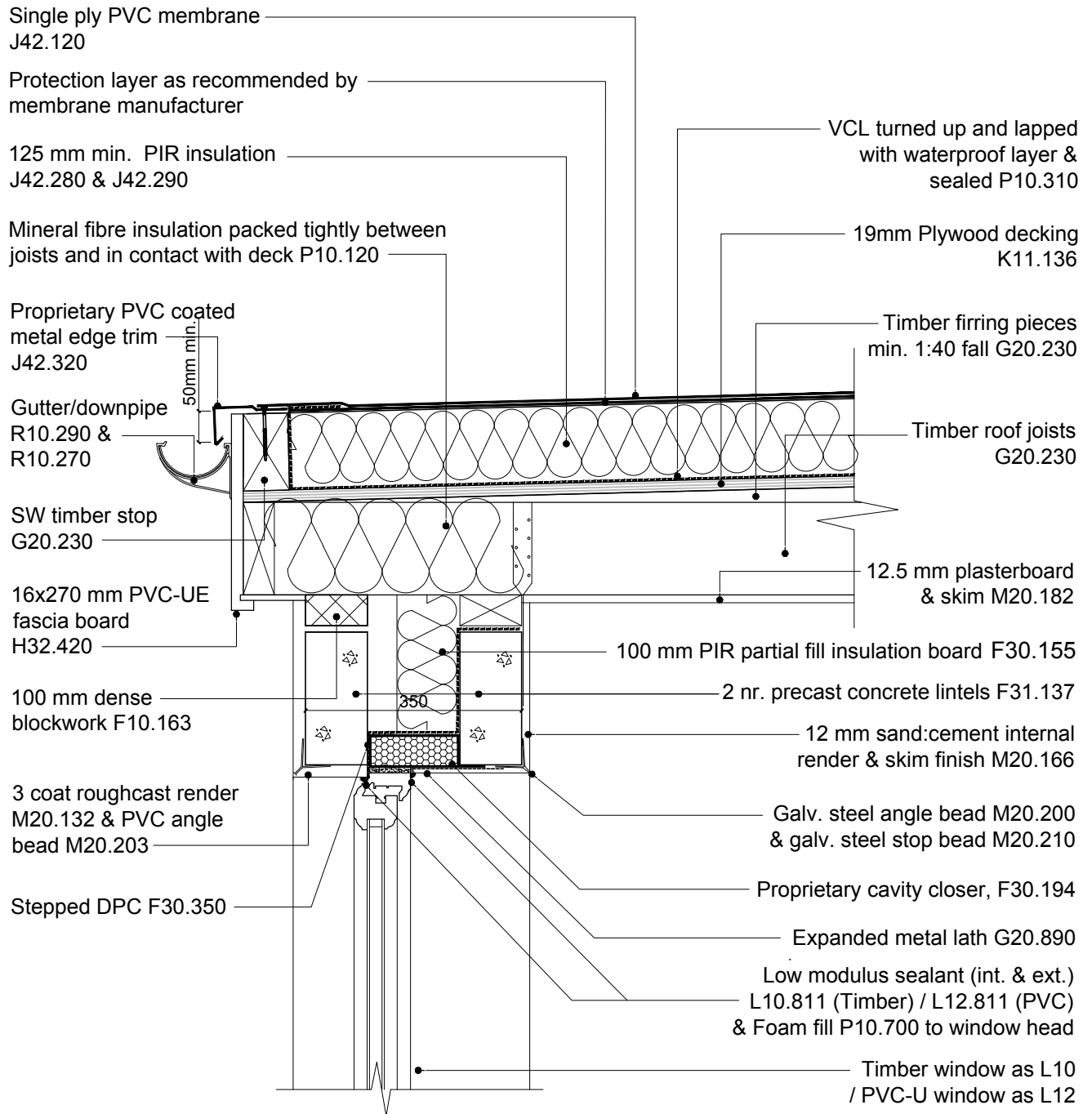

**Notes:**

- Ensure the top of the wall is level and the wall insulation is taken up level with it.
- Fix plasterboard to ceiling before plastering wall and seal all gaps between ceiling and masonry with low-modulus sealant Z22.115.
- Roof timber sizes to comply with current Building Regulations.
- Roof to have a U-value not greater than 0.18 W/m<sup>2</sup>K and walls not greater than 0.28 W/m<sup>2</sup>K.
- Roof to have a fall of no less than 1 in 40, unless otherwise recommended by manufacturer.
- Stainless steel wall ties as F30.214 fixed and staggered at 900mm horizontal & 450mm vertically.
- Windows fitted as per NIHE Codes of Practice L10 (Timber) & L12 (PVC).
- Where a facing brick outer leaf is preferred apply clause F10.151 (general brickwork clause to be completed by the Designer). See Details A(02.11)06 & 18 for insulated steel lintels.

**Housing Executive**

*BCNI Standards Panel Agreed \**

TITLE

**WARM FLAT ROOF**

**Overhanging Eaves Detail**

DRAWN BY <b>P&amp;S</b>	SCALE <b>1:10</b>	DATE <b>Dec '16</b>
DRAWING NO.	<b>A(04.12)11</b>	
REV NO. & DATE		
REV NOTE:		



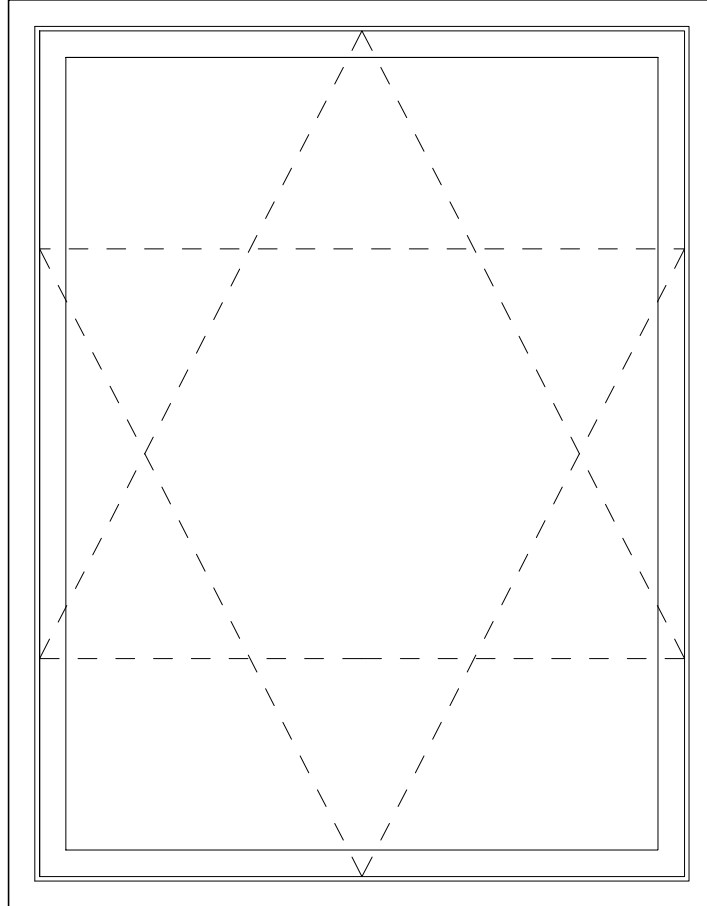

## External Elevation

**NOTES:**

- Pre-finished Timber Windows to be manufactured in accordance with The NIHE Code of Practice L10: 'SPECIFICATION, SURVEY & INSTALLATION OF PRE-FINISHED TIMBER WINDOWS & SIDELIGHTS'

- Background / trickle ventilation to be provided in accordance with the above Code of Practice, i.e: 8000mm<sup>2</sup> min. equivalent area to habitable rooms, and 4000mm<sup>2</sup> min. equivalent area to kitchens, & bathrooms.



TITLE <b>PRE-FINISHED                  TIMBER WINDOWS:                  TYPICAL DETAIL</b>  <b>FULLY REVERSIBLE                  ( Top Swing )</b>	DRAWN BY <b>P&amp;S</b>	SCALE <b>1:10</b>	DATE <b>Jan 02</b>
	DRAWING NO.	<b>C(05.10)25</b>	
	REV NO. & DATE	<b>(3) 12/14</b>	
	REV NOTE: <b>Updated for Building Control</b>		

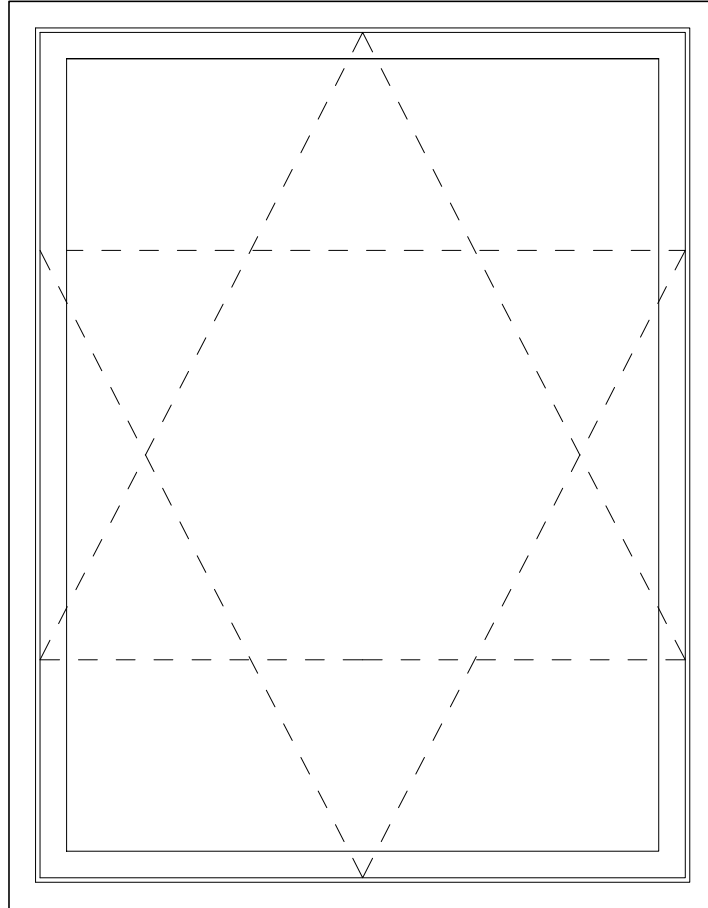

# External Elevation

**NOTES:**

- Pre-finished Timber Windows to be manufactured in accordance with The NIHE Code of Practice L12: 'SPECIFICATION, SURVEY & INSTALLATION OF PVC-U WINDOWS & SIDELIGHTS'

- Background / trickle ventilation to be provided in accordance with the above Code of Practice, i.e:  
8000mm<sup>2</sup> min. equivalent area to habitable rooms, and  
4000mm<sup>2</sup> min. equivalent area to kitchens, & bathrooms.



TITLE PVCu WINDOWS TYPICAL DETAIL  FULLY REVERSIBLE ( Top Hung )	DRAWN BY <b>P&amp;S</b>	SCALE <b>1:10</b>	DATE <b>Feb 07</b>
	DRAWING NO.	<b>C(05.10)28</b>	
	REV NO. & DATE	<b>(2) 11/14</b>	
	REV NOTE: Updated for Building Control		

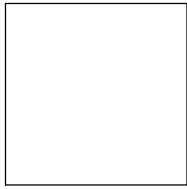

1 FL

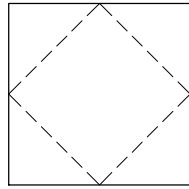

1 OL

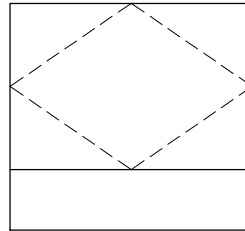

1 OL/1 FL

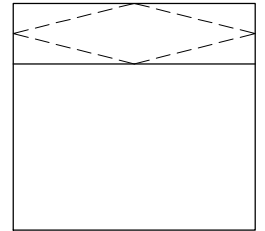

1 OL/1 FL

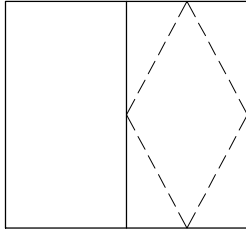

1 OL/1 FL

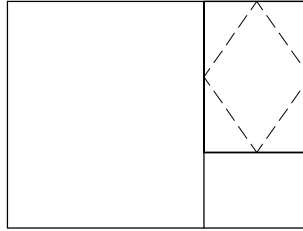

1 OL/2 FL

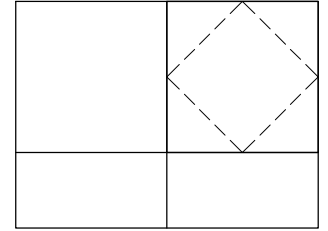

1 OL/3 FL

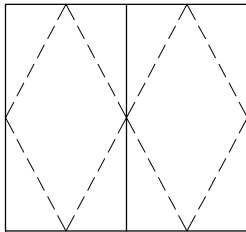

2 OL

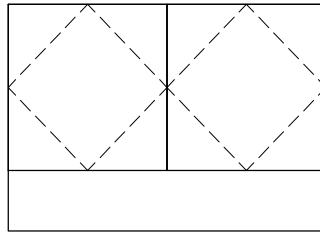

2 OL/1 FL

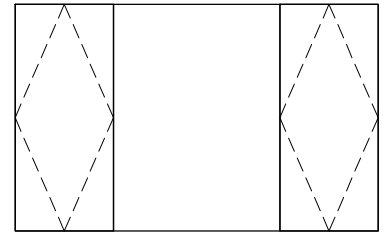

2 OL/1 FL

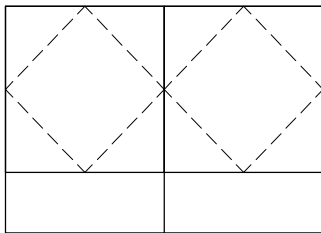

2 OL/2 FL

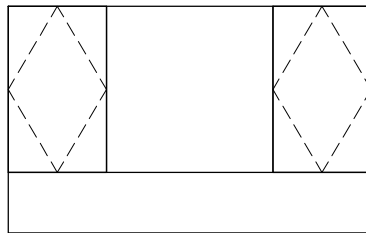

2 OL/2 FL

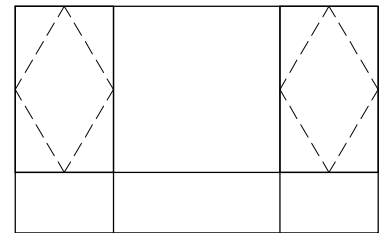

2 OL/4 FL

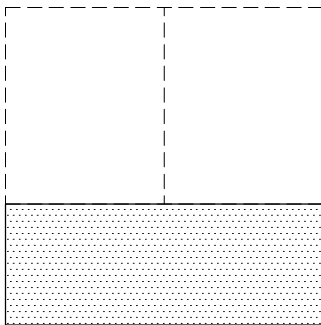

Insulated Infill Panel

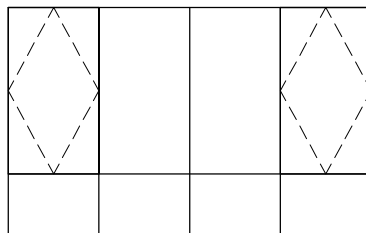

2 OL/6 FL

**KEY:**

Opening Light = OL



Fixed Light = FL



Insulated Infill Panel = IIP



NB: Diagrams do not indicate specific hinge types.  
All dimensions are variable

SPECIFICATION REFERENCES: L10 and L12

© NIHE 2017 DRAWINGS NOT TO BE SCALED DUE TO PRINTING DISTORTION



<b>TITLE</b>  WINDOW FENESTRATION SCHEDULE Timber and PVC	<b>DRAWN BY</b> CB	<b>SCALE</b> 1:50	<b>DATE</b> Nov 12
	<b>DRAWING NO.</b> S(05.10)06		
	<b>REV NO. &amp; DATE</b> (2) 07/16		
	<b>REV NOTE:</b> New window style added		



HINGE SIDE OF DOORLEAF- T-Hinge only

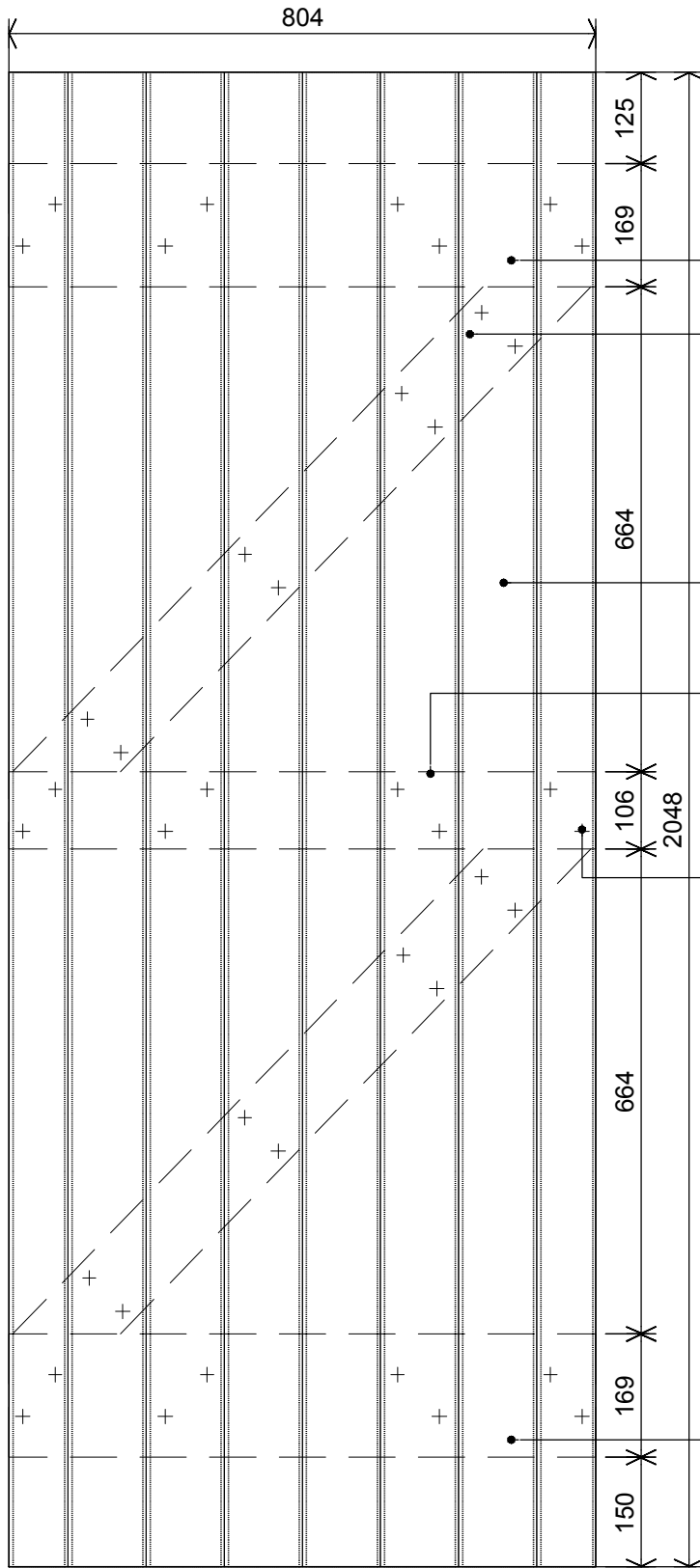

169x20mm top ledge

106x20mm braces

Door sizes (mm): 804 x 2048  
704 x 2048  
604 x 2048  
504 x 2048

114x20mm T&G boarding with pre-primed joints before assembly

106x20mm intermediate rail

Edge sheeting boards and min. 2no. intermediate sheeting boards secured to each rail with 2no. 32mm (No. 8) countersunk wood screws.

Diagonal braces secured as above to alternate sheeting boards. All other sheeting boards to be secured using 32mm galvanised or zinc nails.

Note:  
General assembly fixing and ironmongery as NIHE Code of Practice: L20(2) Lugged, Braced and Sheeted Doors

All external edges of ledges and braces to have 5mm chamfer

169x20mm top ledge

**ELEVATION**

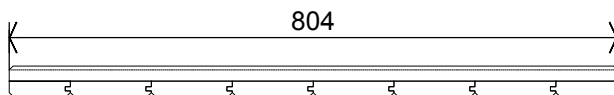

**PLAN**

SPECIFICATION REF: L20/210 and NIHE Code of Practice: L20(2) Lugged, Braced and Sheeted Doors



TITLE	EXTERNAL DOOR		
	Lugged, braced and sheeted		

DRAWN BY	SCALE	DATE
P&S	1:10	Oct 90
DRAWING NO.	C(05.11)07	
REV NO. & DATE	(3) 07/16	
REV NOTE:	T-hinge note added	



© NIHE 2017  
DRAWINGS NOT TO BE SCALED DUE TO PRINTING DISTORTION

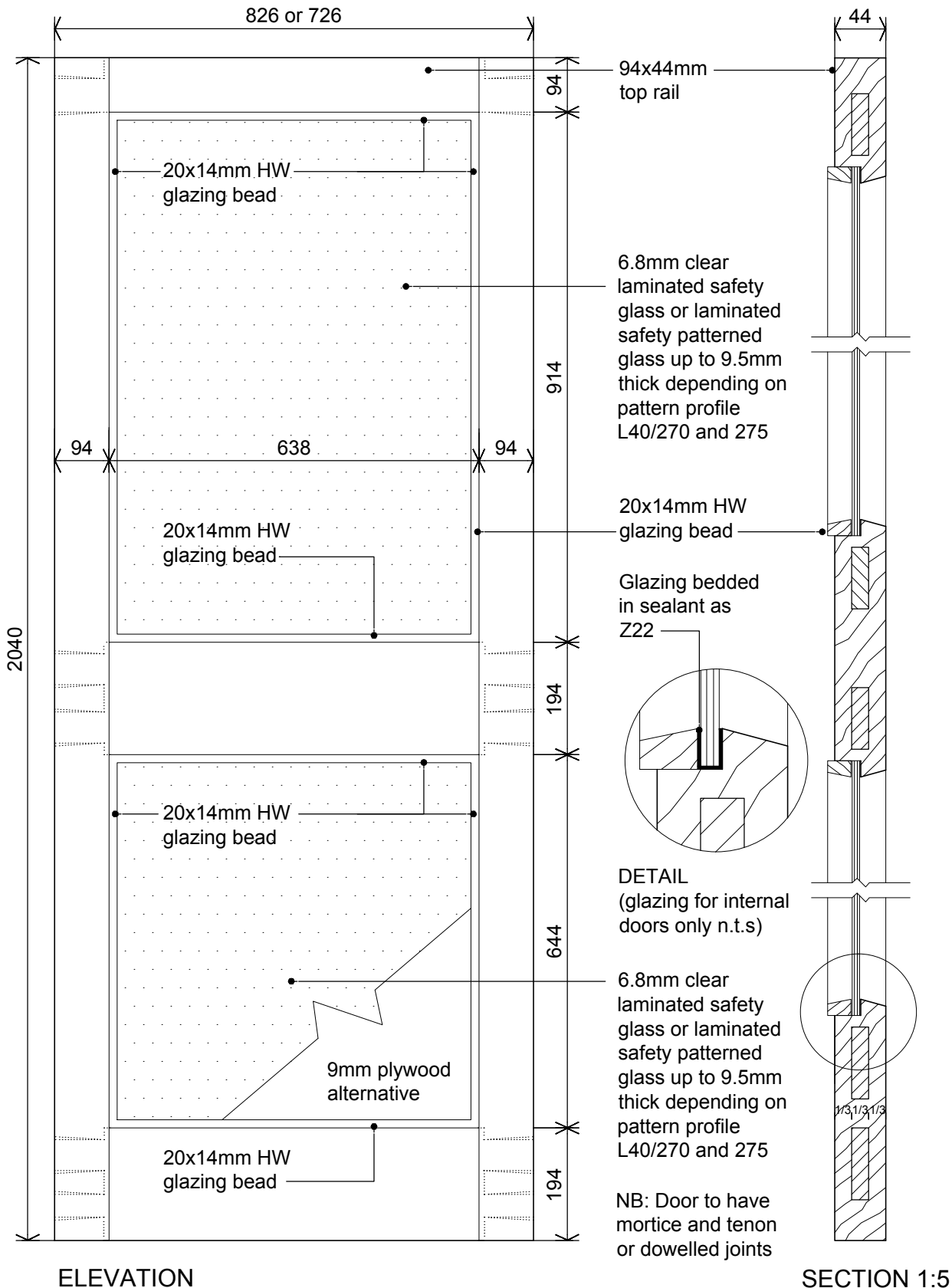

© NIHE 2017  
DRAWINGS NOT TO BE SCALED DUE TO PRINTING DISTORTION



TITLE	INTERNAL DOOR		
	Two panelled glazed door		

DRAWN BY	TJB/CB	SCALE	1:10/1:5	DATE	Aug 90
DRAWING NO.	C(05.11)08				
REV NO. & DATE	(2) 10/12				
REV NOTE:	Updated to revised spec				



SPECIFICATION REF: L20/248, 249, 250, 251



© NIHE 2017  
DRAWINGS NOT TO BE SCALED DUE TO PRINTING DISTORTION

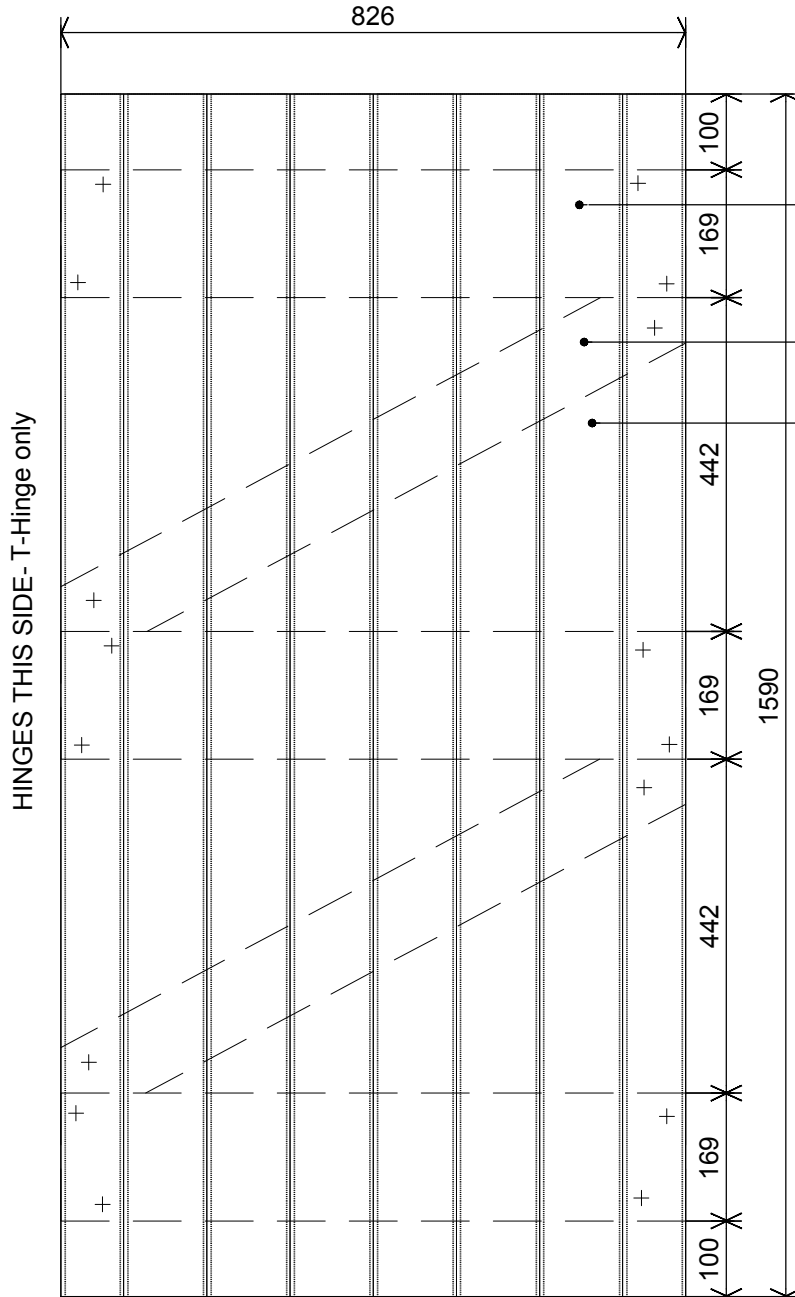

169x20 ledges

106x20mm braces

114x20mm T&G boarding  
with pre-primed joints  
before assembly

Door size (mm) 804x1590

Note:

General assembly fixing to  
include for 60 no. 32mm MS  
cut nails, punched below  
surface for stopping up.

16no. 32mm, No. 9 MS, CS  
screws fixed in locations  
indicated

All external edges of ledges  
and braces to have 5mm  
chamfer

ELEVATION

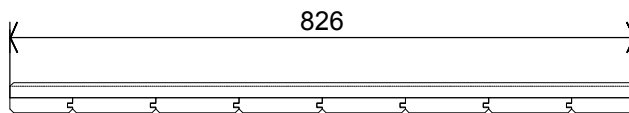

PLAN

SPECIFICATION REF: L20/210



TITLE

EXTERNAL DOOR TO  
BOILER HOUSE -  
BUNGALOWS

Ledged, braced  
and sheeted

DRAWN BY  
P&S

SCALE  
1:10

DATE  
Feb 98

DRAWING NO.

C(05.11)14

REV NO. & DATE

(3) 07/16

REV NOTE:

T-hinge note added



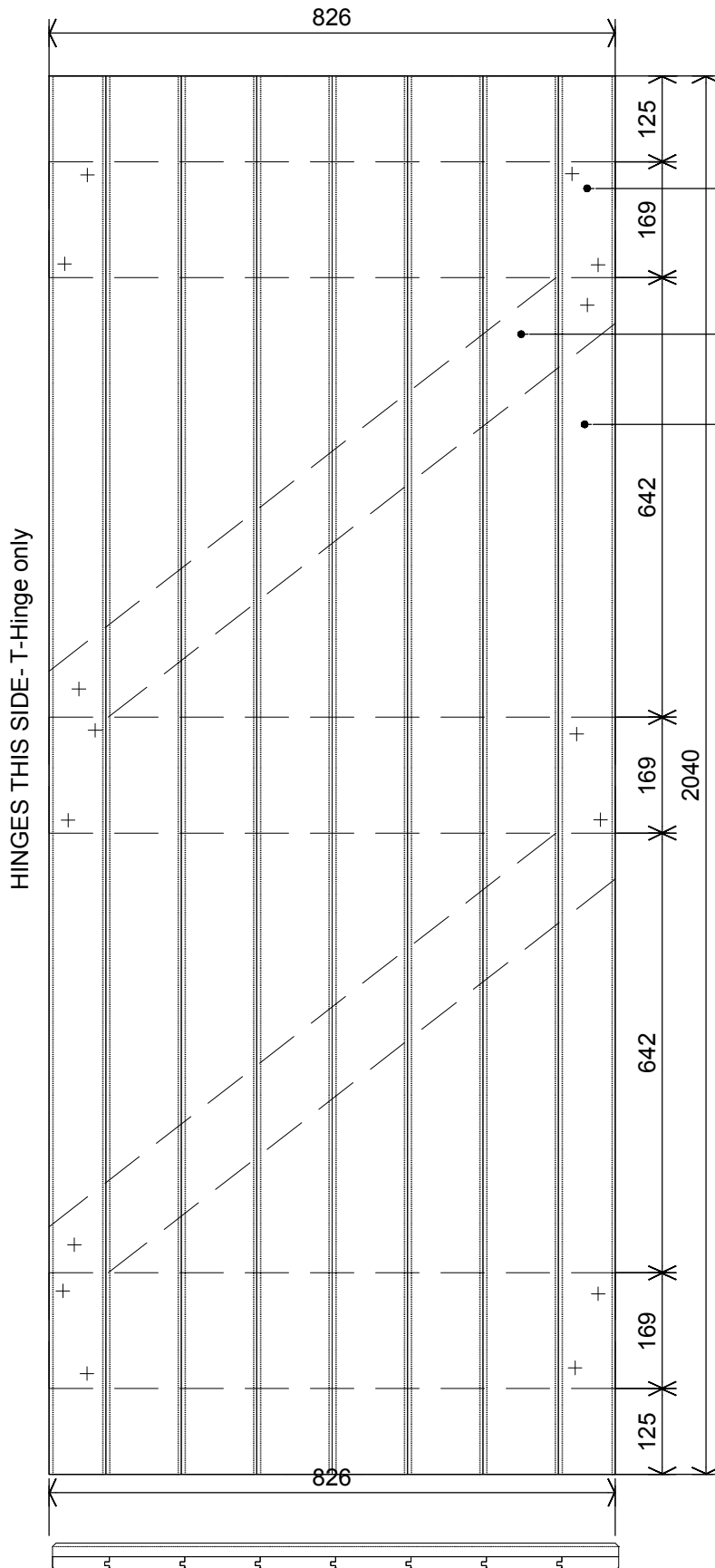

169x20mm ledges

106x20mm braces

114x20mm T&G boarding  
with pre-primed joints  
before assembly

Door size (mm) 804x2040

**Note:**

General assembly fixing to include for 60 no. 32mm MS cut nails, punched below surface for stopping up.

16no. 32mm, No. 9 MS, CS screws fixed in locations indicated

All external edges of ledges and braces to have 5mm chamfer

**ELEVATION**

**PLAN**

SPECIFICATION REF: L20/210

© NIHE 2017  
DRAWINGS NOT TO BE SCALED DUE TO PRINTING DISTORTION



TITLE  
EXTERNAL DOOR TO  
BOILER HOUSE -  
2 STOREY HOUSES  
Ledged, braced  
and sheeted

DRAWN BY <b>P&amp;S</b>	SCALE <b>1:10</b>	DATE <b>Feb 98</b>
DRAWING NO.	<b>C(05.11)15</b>	
REV NO. & DATE	<b>(2) 07/16</b>	
REV NOTE: <b>T-hinge note added</b>		

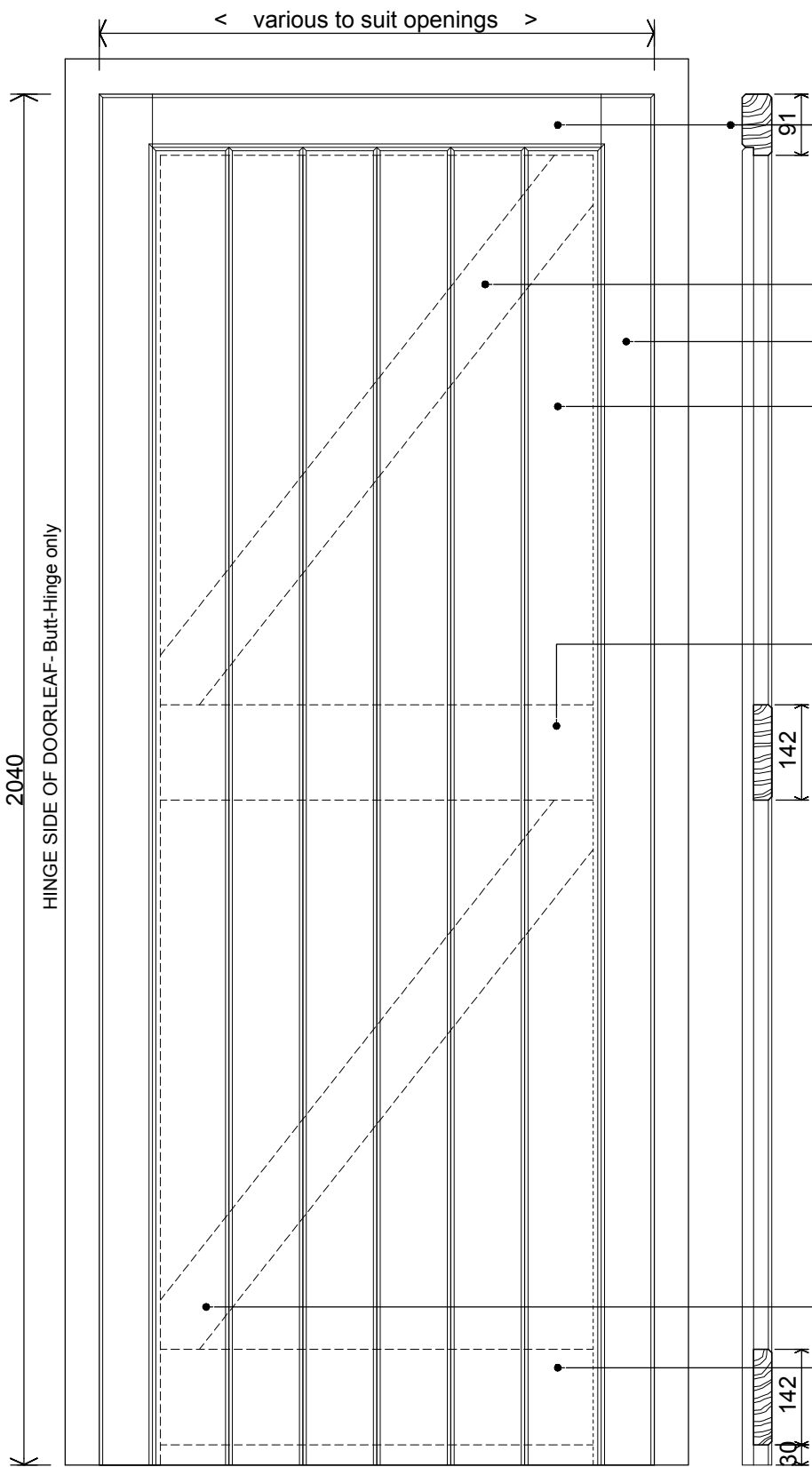

91x44mm SW top horizontal rail mortise-and-tenoned (M&T) into the stiles secured by wedges and adhesive L20/150

91x27mm SW brace

91x44mm SW vertical stiles

111x17mm SW tongued and grooved (T&G) matchboarding plain rebated 12mm (min) into top rail and stiles; and also run over face of bottom rail; boarding to be V-jointed on both sides; and pre-primed before assembly

142x27mm SW middle horizontal rail M&T into stiles and secured by wedges and adhesives L20/150

**NOTES:**  
All external edges of SW rails, braces and stiles to have 5mm chamfer.

Nail fixing of door leaf boarding to be with T-headed or ringed steel nails, 32mm nominal length, driven by mechanically operated tools.

Fixings shall be staggered and shall be driven below the surface for stopping up; with 2no board fixings at each rail and 1no board fixing at each brace; fixings to rebated stiles shall not be more than 200mm apart.

91x27mm SW brace

142x27mm SW bottom horizontal rail M&T into stiles and secured by wedges and adhesives L20/150

FRONT ELEVATION

SECTION

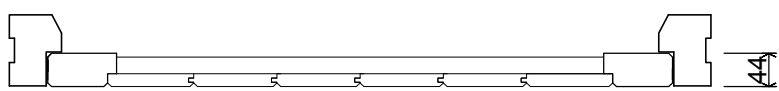

PLAN

SPECIFICATION REFERENCE: L20/215



TITLE  
**EXTERNAL DOOR**  
(Framed, Ledged and Braced)  
Matchboarded Timber Leaf

DRAWN BY <b>P&amp;S</b>	SCALE <b>1:10</b>	DATE <b>Sept 02</b>
DRAWING NO.	<b>C(05.11)23</b>	
REV NO. & DATE	<b>(2) 07/16</b>	

REV NOTE:  
**Butt hinge note added**



# DOOR ASSEMBLY TYPES: Elevations

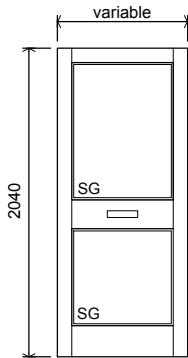

2P.2SG

References:  
L20.990

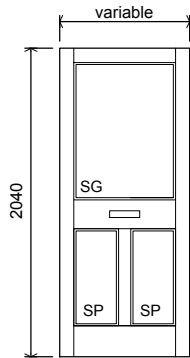

3P.1SG/2SP

References:  
L20.992

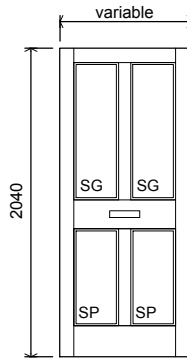

4P.2SG/2SP

References:  
L20.994

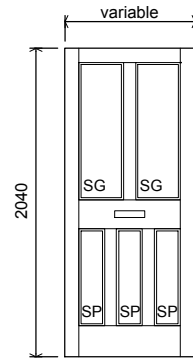

5P.2SG/3SP

References:  
L20.996

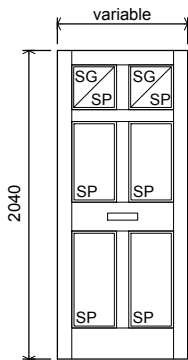

6P.2SG/4SP

References:  
L20.998

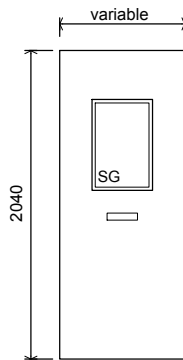

FL.1SG

References:  
L20.245

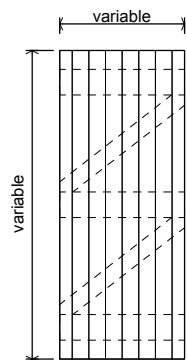

LBS

References:  
C(05.11)07,14,15  
L20.210

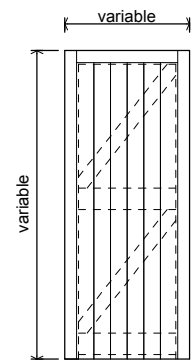

FLBS

References:  
C(05.11)23  
L20.215

**KEY:**







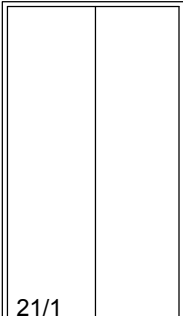
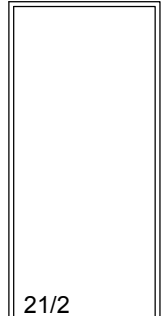
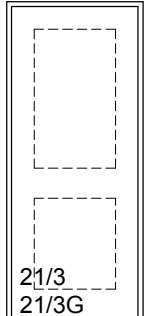
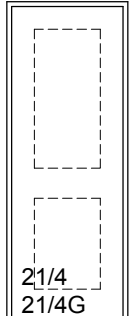
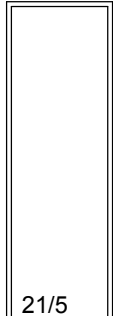
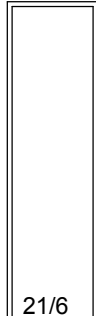

- P = Panels per Door
- SG = Safety Glazing
- SP = Solid Panel
- FL = Flush Door
- FLB = Framed, Ledged and Braced Door
- LBS = Ledged, Braced and Sheeted Door

NB: - Solid panels to be hardwood only, plywood shall not be accepted.  
- All door frames to be fixed using fixing brackets G20/835

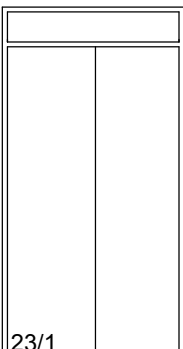
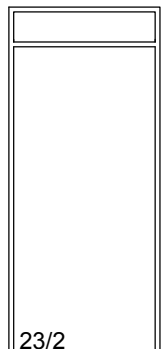
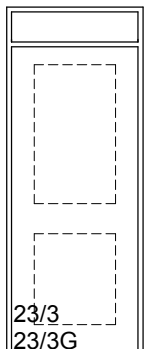
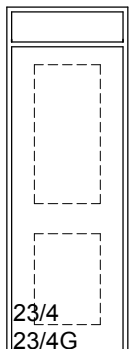
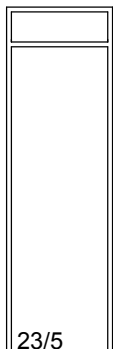
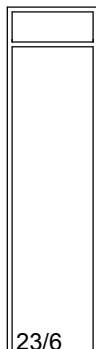
© NIHE 2017  
DRAWINGS NOT TO BE SCALED DUE TO PRINTING DISTORTION

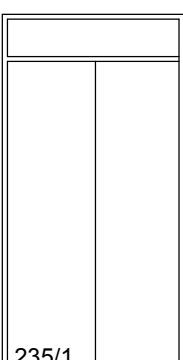
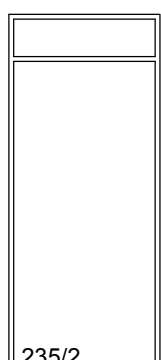
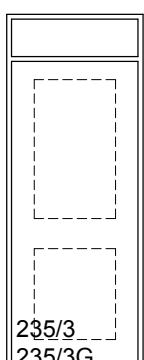
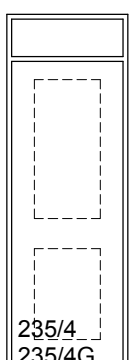
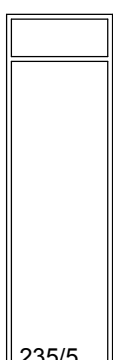
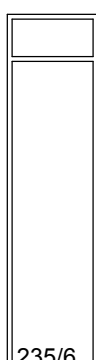

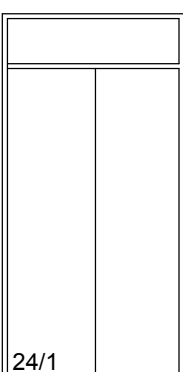
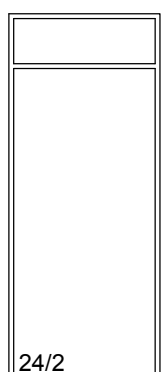
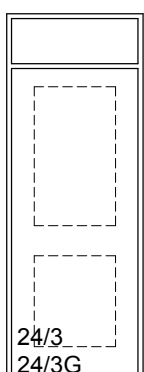
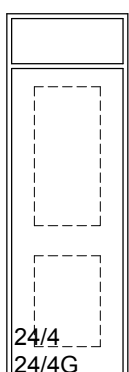
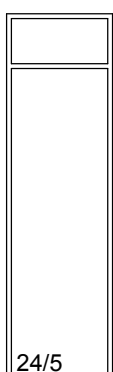
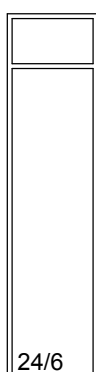
TITLE  <b>SCHEDULE OF STANDARD EXTERNAL DOORS</b>	DRAWN BY <b>TJB/CB</b>	SCALE <b>1:50</b>	DATE <b>Apr 91</b>
	DRAWING NO.	<b>S(05.11)01</b>	
	REV NO. & DATE	<b>(4) 03/17</b>	
	REV NOTE: <b>Updated to revised spec</b>		

	1200	1000	900	800	700	600	500
2100	 21/1	 21/2	 21/3 21/3G	 21/4 21/4G	 21/5	 21/6	 21/7
2300	 23/1	 23/2	 23/3 23/3G	 23/4 23/4G	 23/5	 23/6	 23/7
2350	 235/1	 235/2	 235/3 235/3G	 235/4 235/4G	 235/5	 235/6	 235/7
2400	 24/1	 24/2	 24/3 24/3G	 24/4 24/4G	 24/5	 24/6	 24/7

**NOTES:-**

**DIMENSIONS:-** Work sizes to be 10mm less than the co-ordinating dimensions shown vertically and 6mm horizontally.

**ALTERNATIVE DOORS:** Internal doors generally are flush. In some instances glazed doors may be used internally in the 800 and 900 widths. Alternative doors are shown dotted and described in each range with suffix G.

**FANLIGHTS:** The following suffix to be appended to door/frame description for type of fan-light required:-

(a) Glazed fanlight (b) Plywood fanlight.

**UNDER STAIR DOOR \*32NH ONLY:** 15/3 Block board door with HW lipping.



TITLE <b>SCHEDULE OF STANDARD INTERNAL DOORS AND FRAMES</b>	DRAWN BY <b>TJB/CB</b>	SCALE <b>1:50</b>	DATE <b>Apr 91</b>
	DRAWING NO.	<b>S(05.11)02</b>	
	REV NO. & DATE	<b>(2) 01/13</b>	
	REV NOTE: <b>Updated to revised spec</b>		

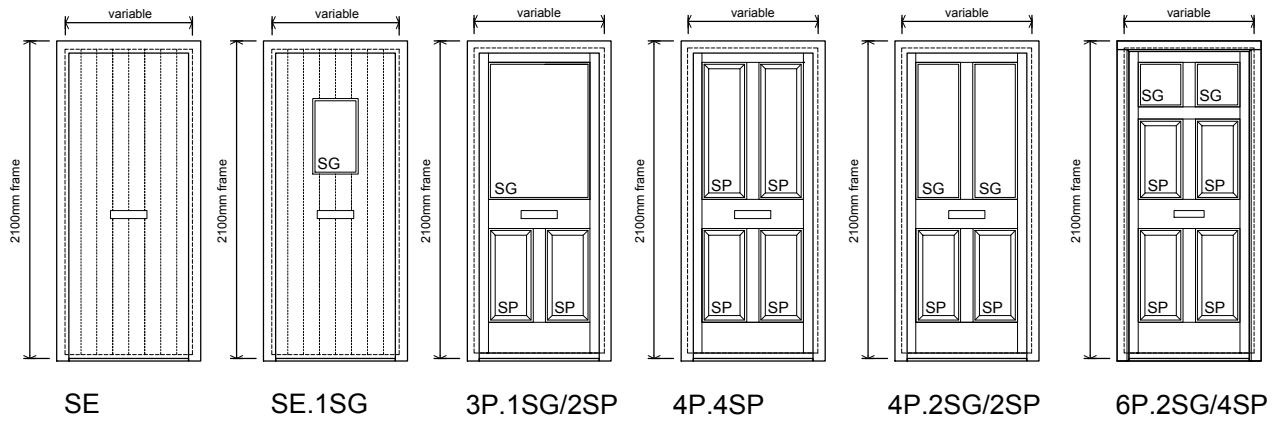

COMPOSITE DOOR ASSEMBLY TYPES: Elevations

			GRP COMPOSITE DOOR			STEEL COMPOSITE DOOR		
			FRAME TYPE			FRAME TYPE		
			NEW WOOD	NEW PVC	EXISTING	NEW WOOD	NEW PVC	EXISTING
DOOR STYLE	3P. 1SG/2SP	WOODGRAIN	L23.200	L23.201	L23.210	L23.220	N/A	L23.230
		SMOOTH	N/A	N/A	N/A	L23.240	N/A	L23.250
	4P. 2SG/2SP	WOODGRAIN	L23.202	L23.203	L23.212	L23.222	N/A	L23.232
		SMOOTH	N/A	N/A	N/A	L23.242	N/A	L23.252
	4P. 4SP	WOODGRAIN	L23.204	L23.205	L23.214	L23.224	N/A	L23.234
		SMOOTH	N/A	N/A	N/A	L23.244	N/A	L23.254
	SE	WOODGRAIN	L23.206	L23.207	L23.216	L23.226	N/A	L23.236
		SMOOTH	N/A	N/A	N/A	L23.246	N/A	L23.256
	SE.1SG	WOODGRAIN	L23.206A	L23.207A	L23.219	N/A	N/A	N/A
		SMOOTH	N/A	N/A	N/A	N/A	N/A	N/A
	6P. 2SG/4SP	WOODGRAIN	L23.208	L23.209	L23.218	L23.228	N/A	L23.238
		SMOOTH	N/A	N/A	N/A	L23.248	N/A	L23.258

TABLE OF COMPOSITE DOORS AND SPECIFICATION REFERENCES

			GLAZING			
			DOOR	SIDE LIGHT	OVER LIGHT	SIDE & OVER LIGHTS
30 min. FIRE DOORS (FD30)	3P. 1SG/2SP	RPF	L23.310/312	N/A	N/A	N/A
		LEC	L23.340/342	N/A	N/A	N/A
		PUR	L23.368/369	N/A	N/A	N/A
	4P. 2SG/2SP	RPF	L23.322/324	N/A	N/A	N/A
		LEC	L23.352/354	N/A	L23.361	N/A
		PUR	L23.370/371	L23.376/377	L23.372/373/374/375	L23.378/379/380/381
	4P. 4SP	RPF	L23.320	N/A	N/A	N/A
		LEC	L23.350	N/A	N/A	N/A
		PUR	L23.364	N/A	N/A	N/A
	6P. 6SP	RPF	L23.330	N/A	N/A	N/A
		LEC	N/A	N/A	N/A	N/A
		PUR	L23.365	N/A	N/A	N/A
	6P. 2SG/4SP	RPF	N/A	N/A	N/A	N/A
		LEC	L23.360	L23.362	N/A	L23.363
		PUR	L23.366/367	N/A	N/A	N/A

KEY:  
P = Panels per Door  
SG = Safety Glazing  
SP = Solid Panel  
SE = Sheeted Effect  
RPF = Rigid Phenolic Foam  
LEC = Lumber Engineered Core  
PUR = Polyurethane Core

TABLE OF COMPOSITE FIRE DOORS AND SPECIFICATION REFERENCES

	TITLE	DRAWN BY	SCALE	DATE
	EXTERNAL ENTRANCE	CgR/CB	1:50	Nov 06
	Schedule of factory pre-finished external door-set types	DRAWING NO.	S(05.11)06	
	COMPOSITE	REV NO. & DATE	(2) 02/17	
		REV NOTE:	New style added	

© NIHE 2017 DRAWINGS NOT TO BE SCALED DUE TO PRINTING DISTORTION

\* This NIHE produced detail has been examined by The Building Control N.I. Standards Panel and has been considered reasonable in its interpretation of the relevant requirements of the Building Regulation NI 2012. There is no legal obligation for any Building Control department to adopt this recommendation & it is subject to revision in the event of changes to the legislation or other mitigating circumstances.

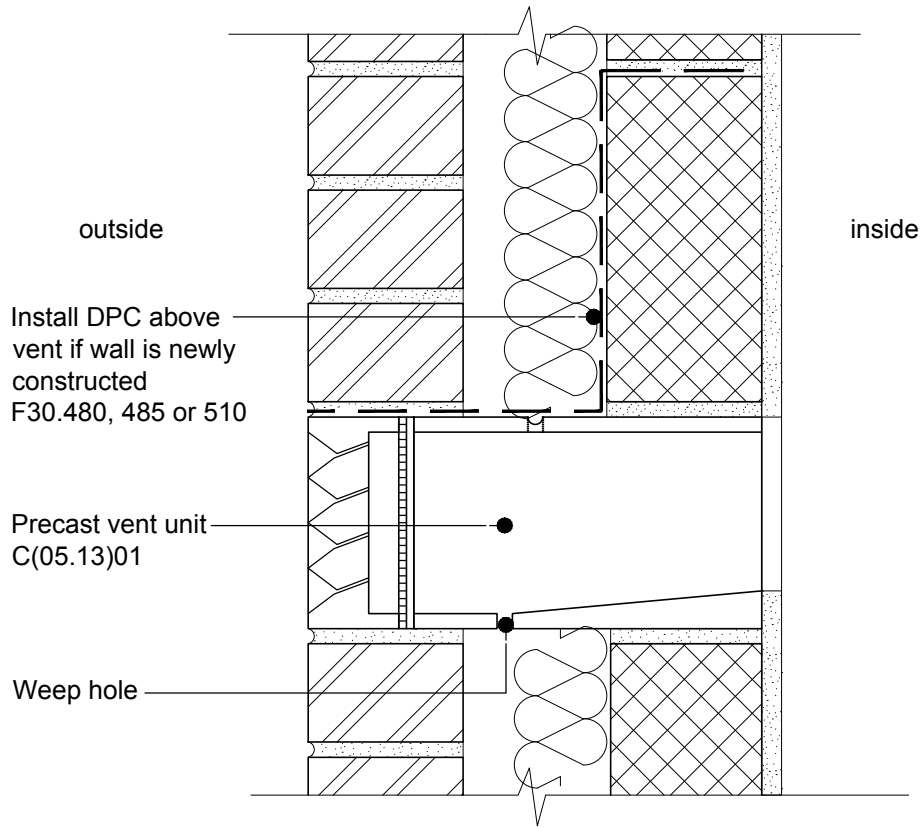

SECTION

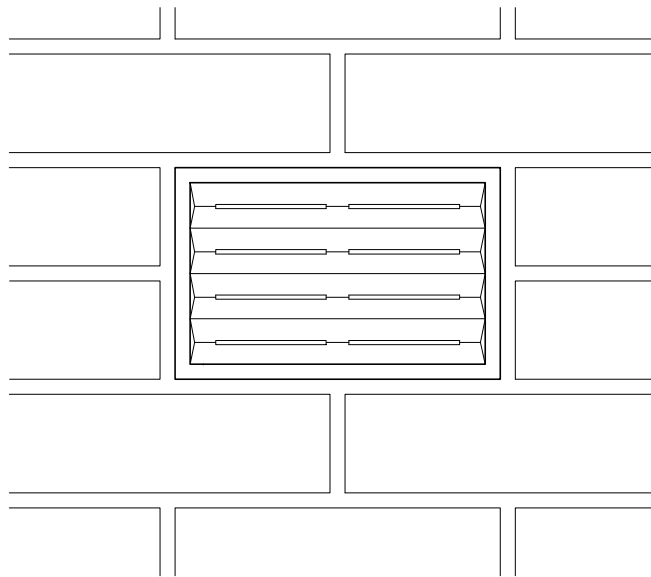

ELEVATION

NB: CAVITY BOX TO BE NON ABSORBENT WATERPROOF CONCRETE OR FIRECLAY

SPECIFICATION REFERENCE F30.160,170



TITLE <b>TWO PART PRECAST VENTILATION UNIT</b>	DRAWN BY <b>P&amp;S</b>	SCALE <b>1:5</b>	DATE <b>Feb 91</b>
	DRAWING NO.	<b>A(05.13)01</b>	
	REV NO. & DATE	<b>(2) 11/14</b>	
	REV NOTE: <b>Updated for Building Control</b>		

\* This NIHE produced detail has been examined by The Building Control N.I. Standards Panel and has been considered reasonable in its interpretation of the relevant requirements of the Building Regulation NI 2012. There is no legal obligation for any Building Control department to adopt this recommendation & it is subject to revision in the event of changes to the legislation or other mitigating circumstances.

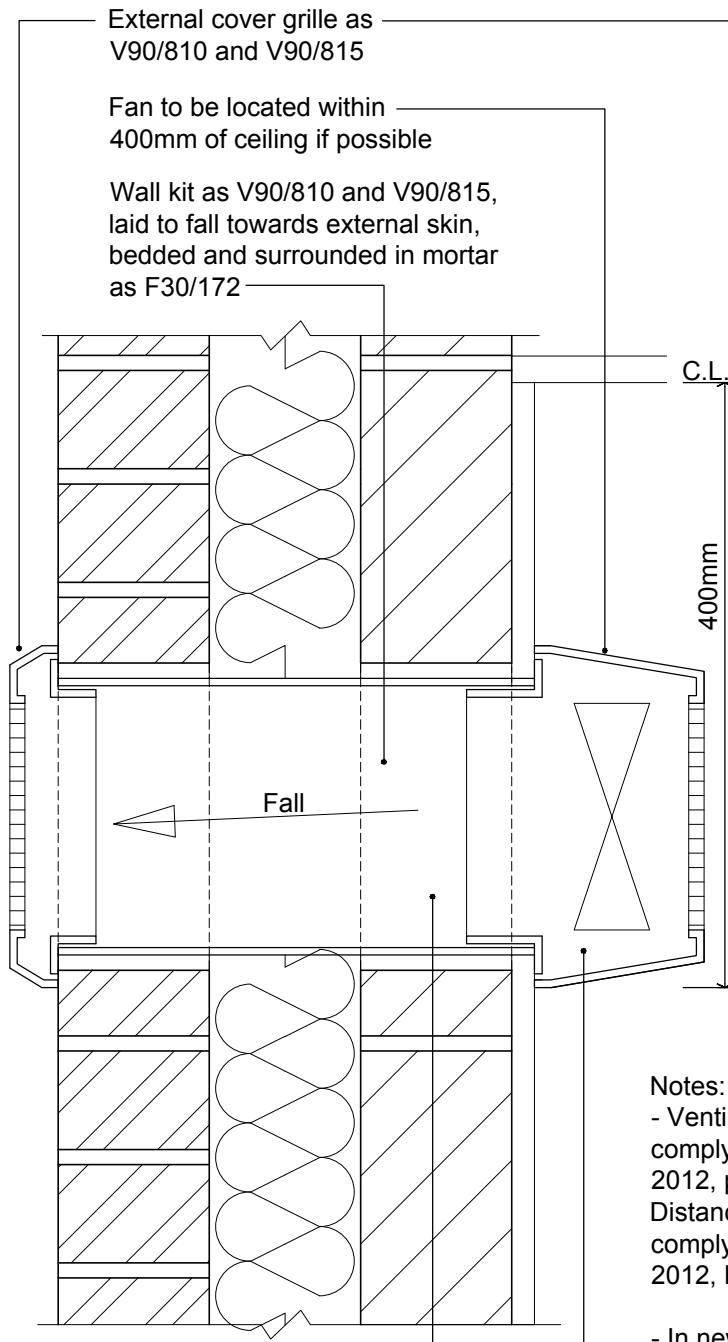

SECTION A:A (1:5)

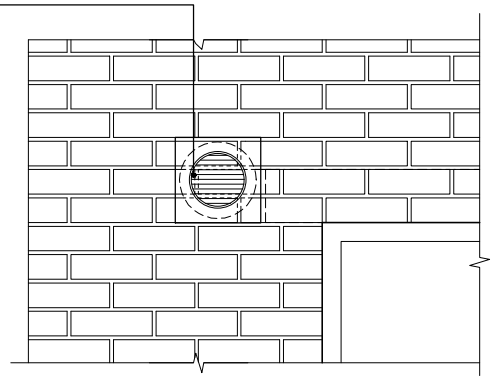

EXTERNAL ELEVATION

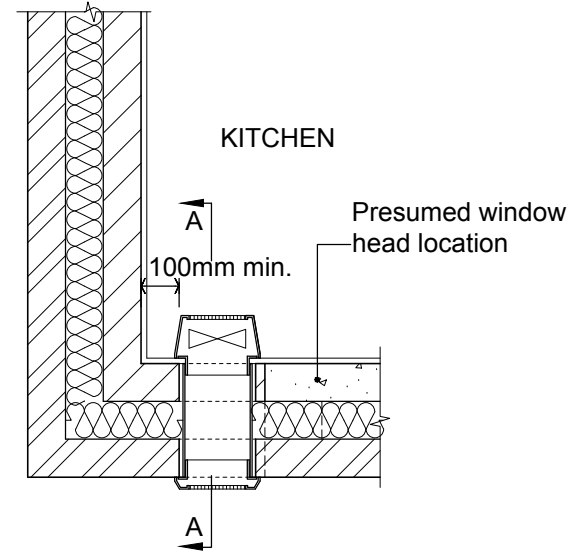

TYPICAL PLAN LOCATION

Notes:

- Ventilation rates and extractor fan locations are to comply with Building Regulations Technical Booklet K, 2012, par. 2.16 and 2.18.
- Distance between extractor outlets and flue outlets to comply with Building Regulations Technical Booklet L, 2012, Dia. 4.3 and Table 4.3
- In new wall construction, a stepped cavity tray as F30/480 should be built in above the duct.
- Kitchen fan extraction rate 60 l/s (min). Bathroom fan extraction rate 15 l/s (min) (with 15min over-run facility if there are no openable windows).
- All accessories to be in accordance with fan manufacturers' requirements. Ventilator material alternatives to fan manufacturers' recommendations.
- Extract fan to be adequately sealed with low modulus sealant Z22.115 both internally & externally, to provide an airtight junction.

SPECIFICATION REFERENCES V90/810 AND V90/815

DRAWINGS NOT TO BE SCALED DUE TO PRINTING DISTORTION

**Housing Executive**

**BCNI Standards Panel Agreed \***

TITLE  
EXTRACT VENTILATION  
KITCHEN AND BATHROOM  
WALL MOUNTED FAN WITH  
ROUND DUCT OUTLET

DRAWN BY <b>P&amp;S</b>	SCALE 1:20, 1:5	DATE Apr 91
DRAWING NO.	A(05.13)02	
REV NO. & DATE	(6) 11/14	
REV NOTE: Updated for Building Control		





\* This NIHE produced detail has been examined by The Building Control N.I. Standards Panel and has been considered reasonable in its interpretation of the relevant requirements of the Building Regulation NI 2012. There is no legal obligation for any Building Control department to adopt this recommendation & it is subject to revision in the event of changes to the legislation or other mitigating circumstances.

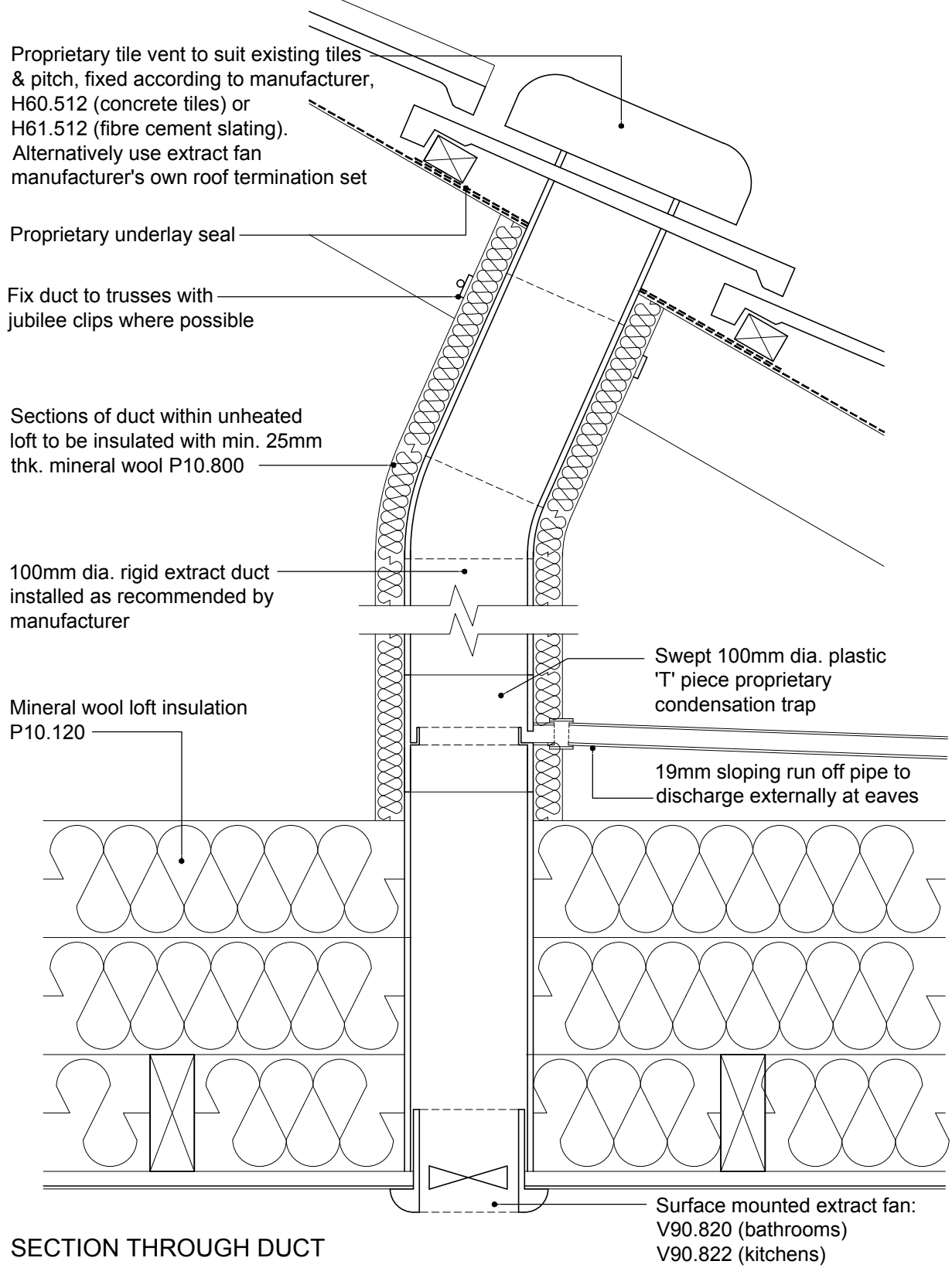

**SECTION THROUGH DUCT**

**NOTES:**

- Apply sealant to ceiling around extract fan as Z20.110
- Connect fan to extract duct and keep bends and length of ducting to a minimum, as per manufacturer's instructions.
- Where tile vent is connected to a cooker hood, section of duct between hood and ceiling is to be boxed in neatly and painted to match walls.

© NIHE 2017 DRAWINGS NOT TO BE SCALED DUE TO PRINTING DISTORTION

**Housing Executive**

*BCNI Standards Panel Agreed \**

TITLE	EXTRACT DUCT THROUGH PITCHED ROOF (for extract fans & cooker hoods)		
-------	---	--	--

DRAWN BY	P&S	SCALE	1:5	DATE	Sept 94
DRAWING NO.	A(05.13)04				
REV NO. & DATE	(2) 01/15				
REV NOTE:	Updated to revised spec				

\* This NIHE produced detail has been examined by The Building Control N.I. Standards Panel and has been considered reasonable in its interpretation of the relevant requirements of the Building Regulation NI 2012. There is no legal obligation for any Building Control department to adopt this recommendation & it is subject to revision in the event of changes to the legislation or other mitigating circumstances.

Cooker hood low profile exhaust duct along top of kitchen wall units as V90/864. Laid to fall towards external skin, bedded and surrounded in mortar as F30/174

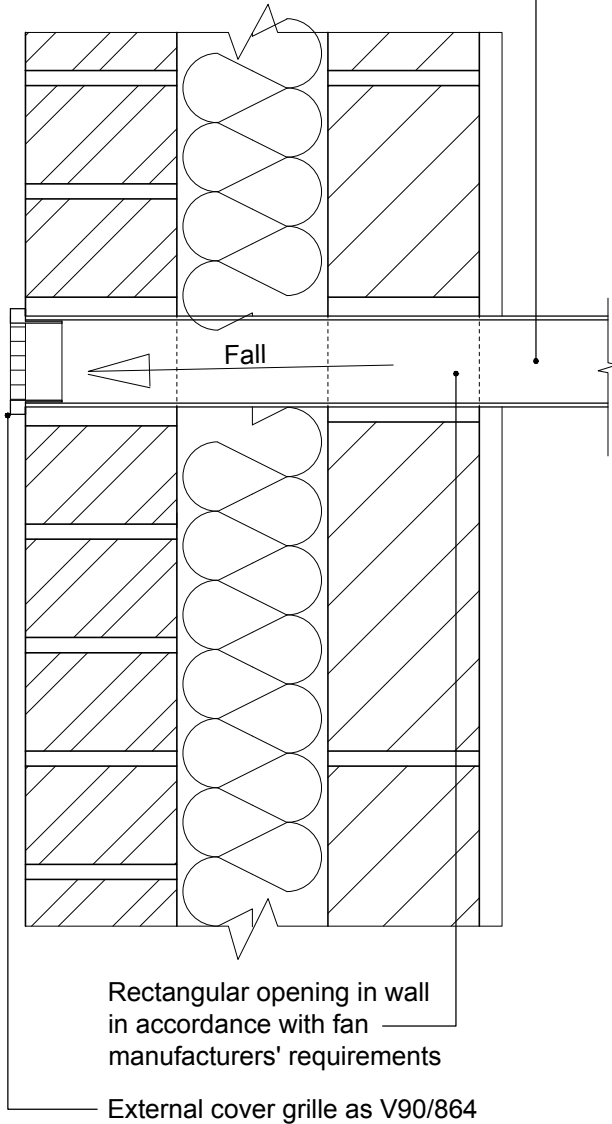

SECTION A:A (1:5)

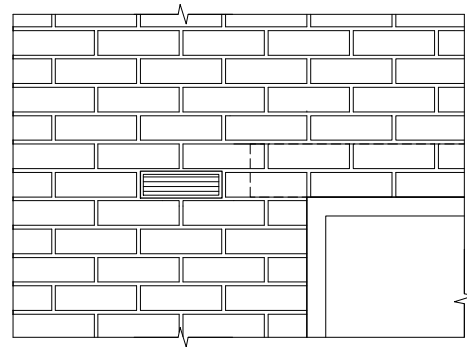

EXTERNAL ELEVATION

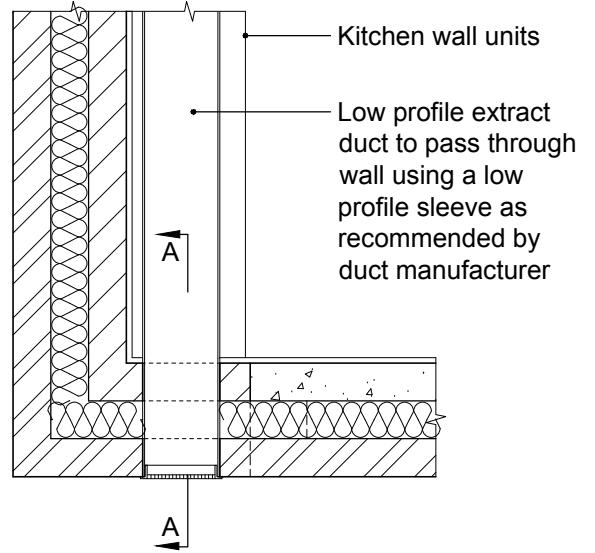

TYPICAL PLAN LOCATION

Notes:

- Ventilation rates and cooker hood location to comply with Building Regulations Technical Booklet K, Oct 2012, par. 2.17. Distance between extractor outlets and flue outlets to comply with Building Regulations Technical Booklet L, 2012, Dia. 4.3 and Table 4.3
- In new wall construction, a stepped cavity tray as F30/480 should be built in above the duct.
- Cooker hood extraction rate 30 l/s (min).
- All accessories to be in accordance with fan manufacturers' requirements. Ventilator material alternatives to fan manufacturers' recommendations.
- Extract duct to be adequately sealed with low modulus sealant Z22.115 both internally & externally, to provide an airtight junction.

SPECIFICATION REFERENCES V90/864

© NIHE 2017 DRAWINGS NOT TO BE SCALED DUE TO PRINTING DISTORTION



TITLE EXTRACT VENTILATION KITCHEN COOKER HOOD WITH FLAT CHANNEL OUTLET	DRAWN BY <b>P&amp;S</b>	SCALE 1:20, 1:5	DATE Nov. 12
	DRAWING NO. A(05.13)06		
	REV NO. & DATE (1) 11/14		
	REV NOTE: Updated for Building Control		



\* This NIHE produced detail has been examined by The Building Control N.I. Standards Panel and has been considered reasonable in its interpretation of the relevant requirements of the Building Regulation NI 2012. There is no legal obligation for any Building Control department to adopt this recommendation & it is subject to revision in the event of changes to the legislation or other mitigating circumstances.

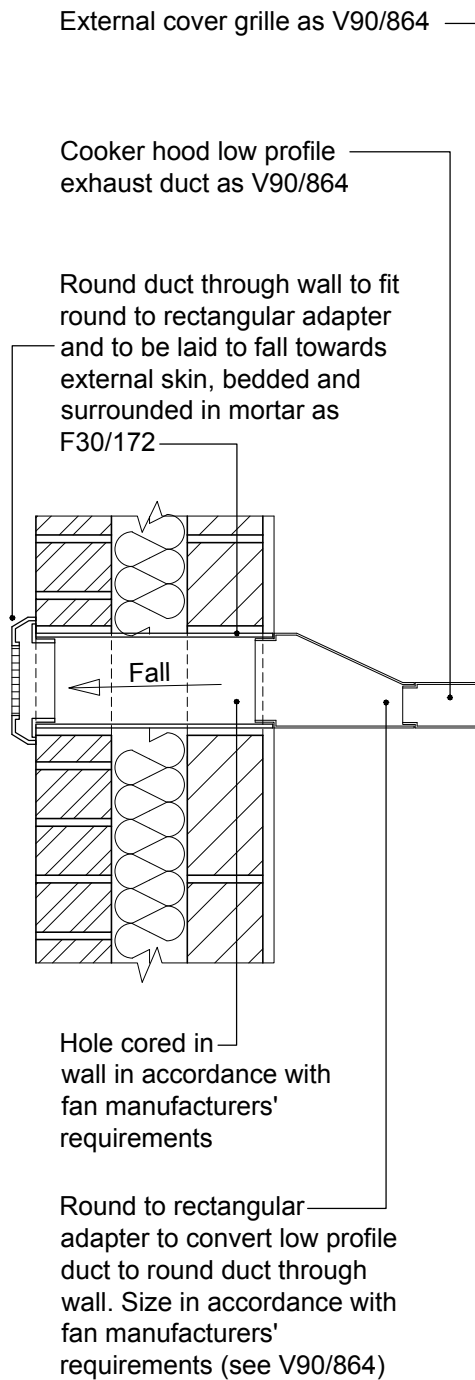

SECTION A:A (1:10)

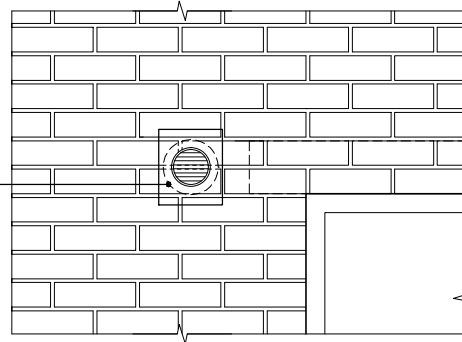

EXTERNAL ELEVATION

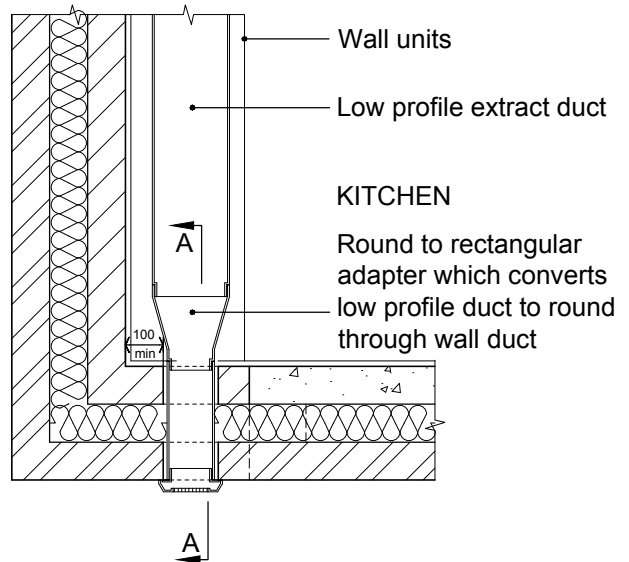

TYPICAL PLAN LOCATION

Notes:

- Ventilation rates and cooker hood location to comply with Building Regulations Technical Booklet K, Oct 2012, par. 2.17. Distance between extractor outlets and flue outlets to comply with Building Regulations Technical Booklet L, 2012, Dia. 4.3 and Table 4.3
- In new wall construction, a stepped cavity tray as F30/480 should be built in above the duct.
- Cooker hood extraction rate 30 l/s (min).
- All accessories to be in accordance with fan manufacturers' requirements. Ventilator material alternatives to fan manufacturers' recommendations.
- Extract duct to be adequately sealed with low modulus sealant Z22.115 both internally & externally, to provide an airtight junction.

SPECIFICATION REFERENCES V90/864

© NIHE 2017 DRAWINGS NOT TO BE SCALED DUE TO PRINTING DISTORTION



TITLE EXTRACT VENTILATION KITCHEN COOKER HOOD WITH ROUND DUCT OUTLET	DRAWN BY CB	SCALE 1:20, 1:10	DATE Nov 12
	DRAWING NO.	A(05.13)07	
	REV NO. & DATE	(1) 11/14	
	REV NOTE: Updated for Building Control		

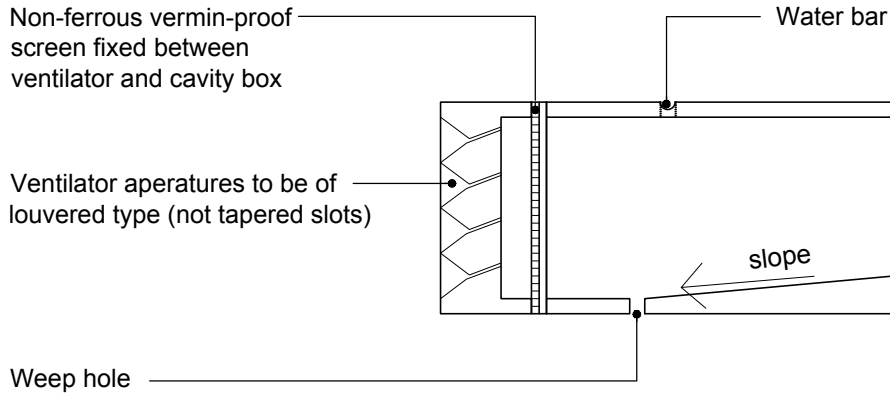

SECTION

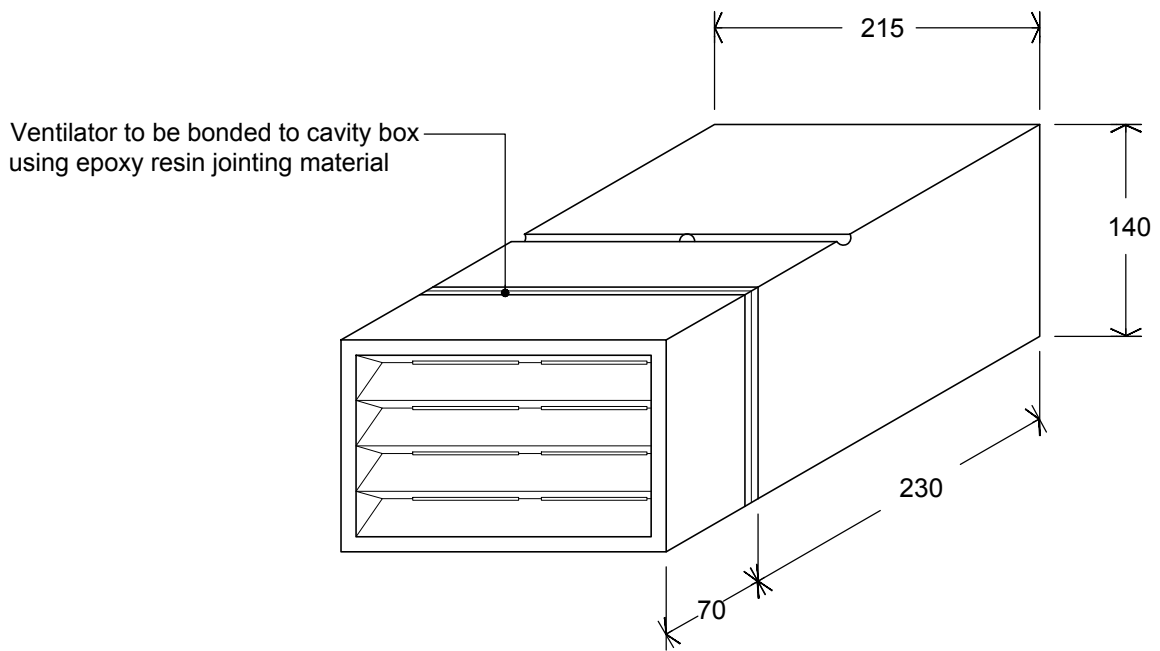

PROJECTED VIEW

CAVITY BOX TO BE NON ABSORBENT WATERPROOF CONCRETE OR FIRECLAY

SPECIFICATION REFERENCE F30/170



TITLE  <b>PRE-CAST VENTILATOR</b>	DRAWN BY <b>L.M.</b>	SCALE <b>1:5</b>	DATE <b>Aug 90</b>
	DRAWING NO.	<b>C(05.13)01</b>	
	REV NO. & DATE		
	REV NOTE:		

\* This NIHE produced detail has been examined by The Building Control N.I. Standards Panel and has been considered reasonable in its interpretation of the relevant requirements of the Building Regulation NI 2012. There is no legal obligation for any Building Control department to adopt this recommendation & it is subject to revision in the event of changes to the legislation or other mitigating circumstances.

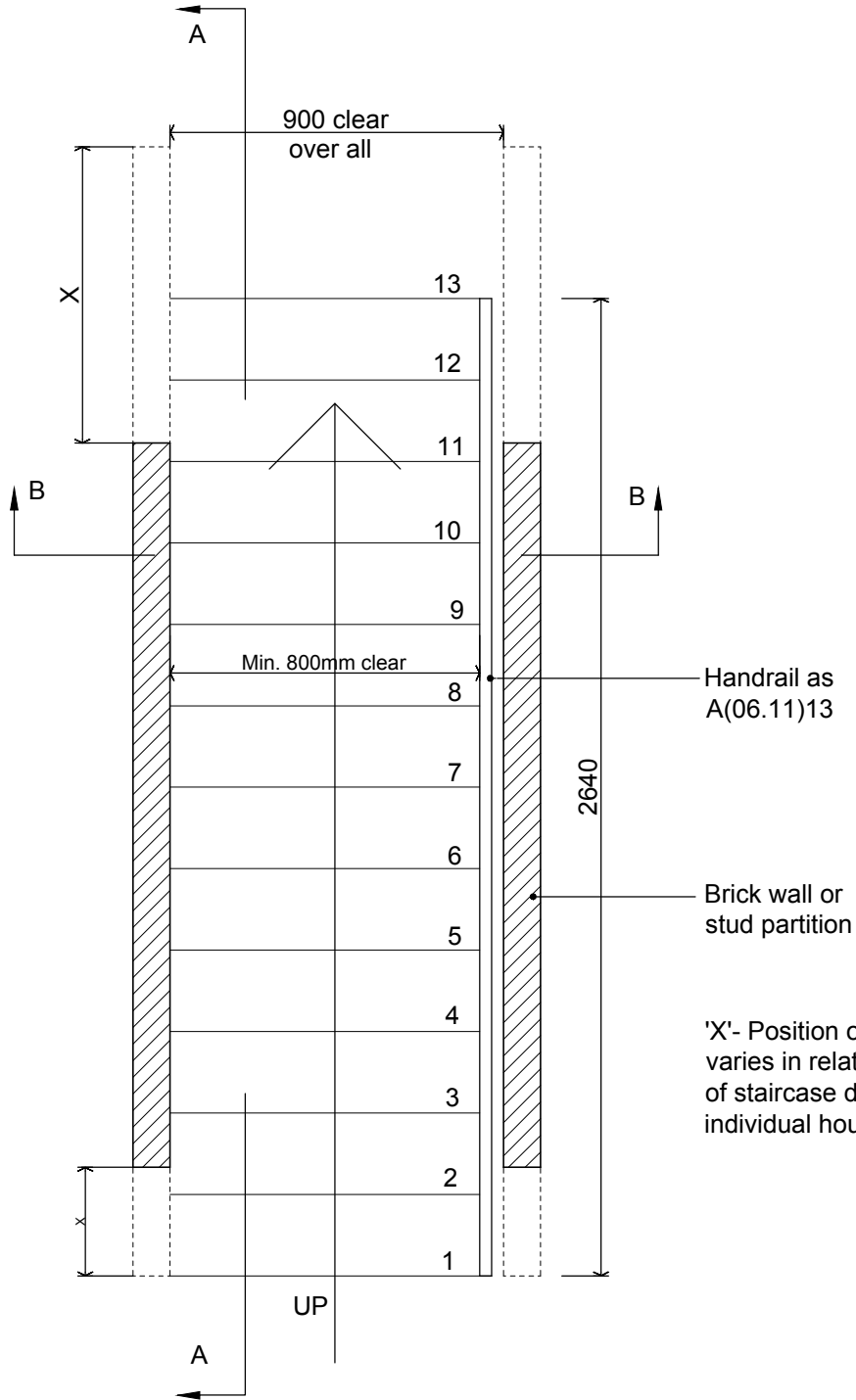

PLAN

NOTES:

- Where possible, stairs are to comply with current Building Control Regulations, Technical Booklet H.
- Max. riser 220mm, min. going 220mm, max. pitch 42°.
- $2R(\text{risers}) + G(\text{going})$  to be between 550 & 700mm.
- Where replacement stairs do not fit within available space either replace exactly 'like for like' or seek Building Control guidance.
- See drawing A(06.11)02 for Longitudinal Section A/A
- See drawing A(06.11)04 for Cross Section B/B

SPEC REFERENCE: L30.270



**BCNI Standards  
Panel Agreed \***

TITLE

PLAN OF STRAIGHT  
FLIGHT, TIMBER STAIR  
TO EXISTING DWELLINGS

DRAWN BY  
P&S

SCALE  
1:20

DATE  
Apr 91

DRAWING NO.

A(06.11)01

REV NO. & DATE

(3) 11/14

REV NOTE:

Updated for Building Control



\* This NIHE produced detail has been examined by The Building Control N.I. Standards Panel and has been considered reasonable in its interpretation of the relevant requirements of the Building Regulation NI 2012. There is no legal obligation for any Building Control department to adopt this recommendation & it is subject to revision in the event of changes to the legislation or other mitigating circumstances.

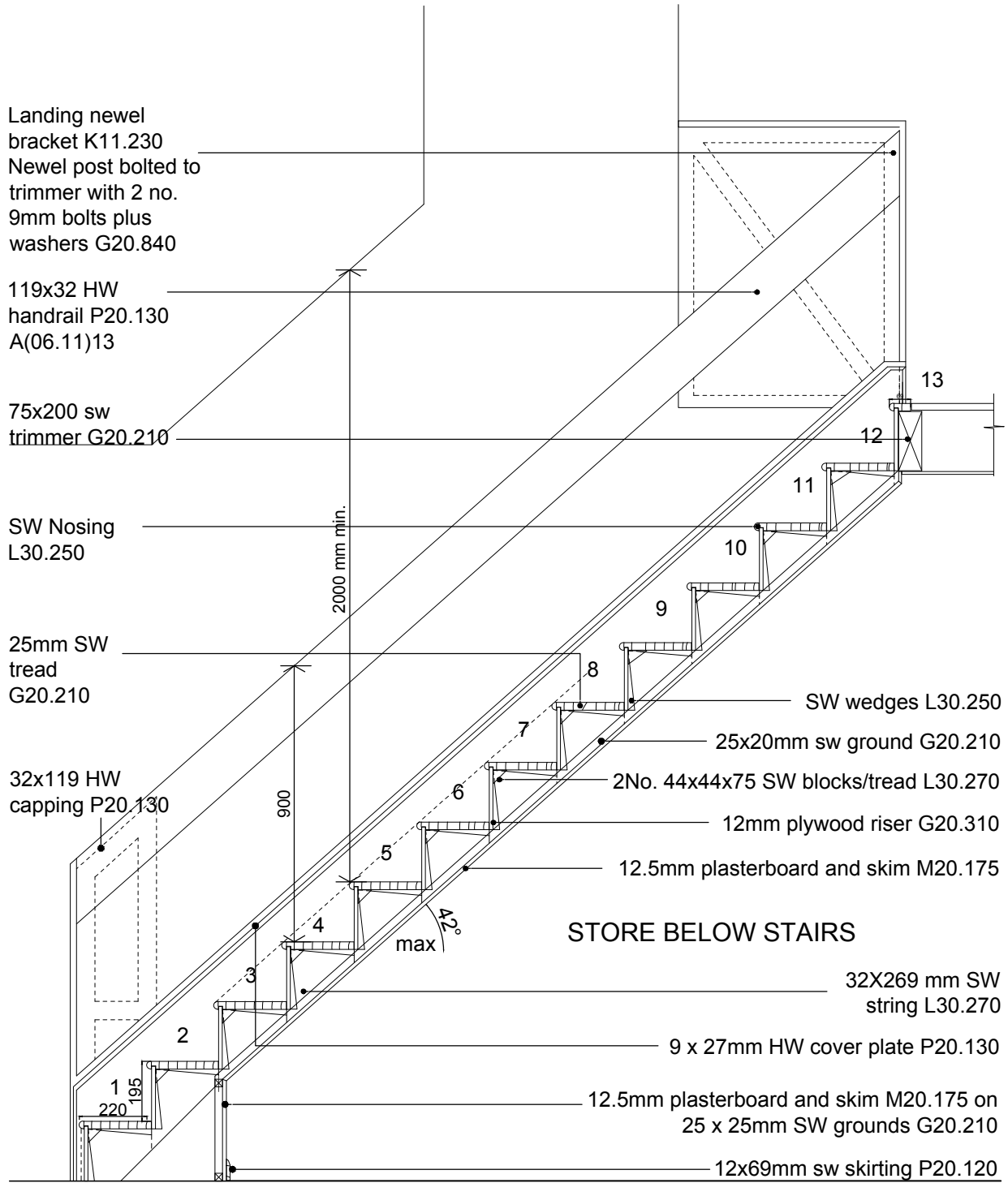

**NOTES:**

- Where possible, stairs are to comply with current Building Control Regulations, Technical Booklet H.
- Max. riser 220mm, min. going 220mm, max. pitch 42°.
- 2R(risers)+G(going) to be between 550 & 700mm.
- Where replacement stairs do not fit within available space either replace exactly 'like for like' or seek Building Control guidance.
- See drawing A(06.11)02 for Longitudinal Section A/A.
- See drawing A(06.11)04 for Cross Section B/B.
- Handrail to be able to resist 0.36kN/m of horizontal force.

SPEC REFERENCE: L30.270



TITLE  
**13 RISER STRAIGHT  
 FLIGHT STAIRCASE  
 WITHIN EXISTING  
 DWELLINGS**  
 Longitudinal Section A/A

DRAWN BY <b>P&amp;S</b>	SCALE <b>1:20</b>	DATE <b>Apr 91</b>
DRAWING NO.	<b>A(06.11)02</b>	
REV NO. & DATE	<b>(6) 07/16</b>	
REV NOTE: Updated for Building Control		



\* This NIHE produced detail has been examined by The Building Control N.I. Standards Panel and has been considered reasonable in its interpretation of the relevant requirements of the Building Regulation NI 2012. There is no legal obligation for any Building Control department to adopt this recommendation & it is subject to revision in the event of changes to the legislation or other mitigating circumstances.

Landing Newel Bracket G20.837  
 Landing Newel Post bolted to trimmer with 2no. 9mm bolts plus washers G20/840

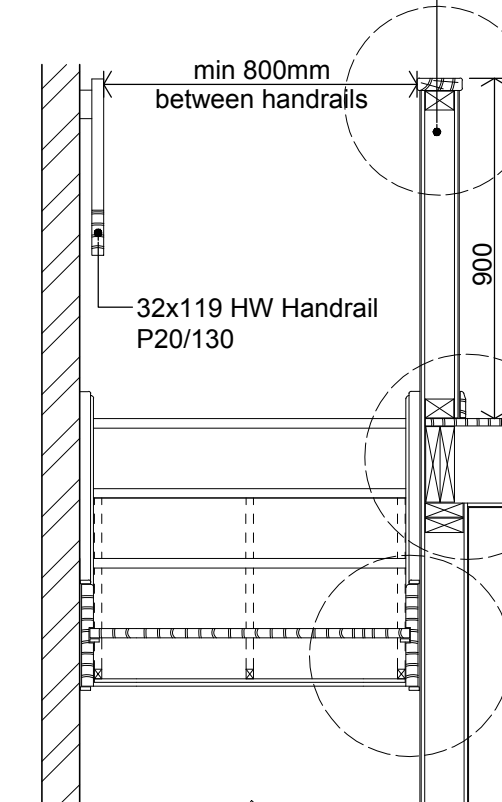

CROSS SECTION B/B (1:20)

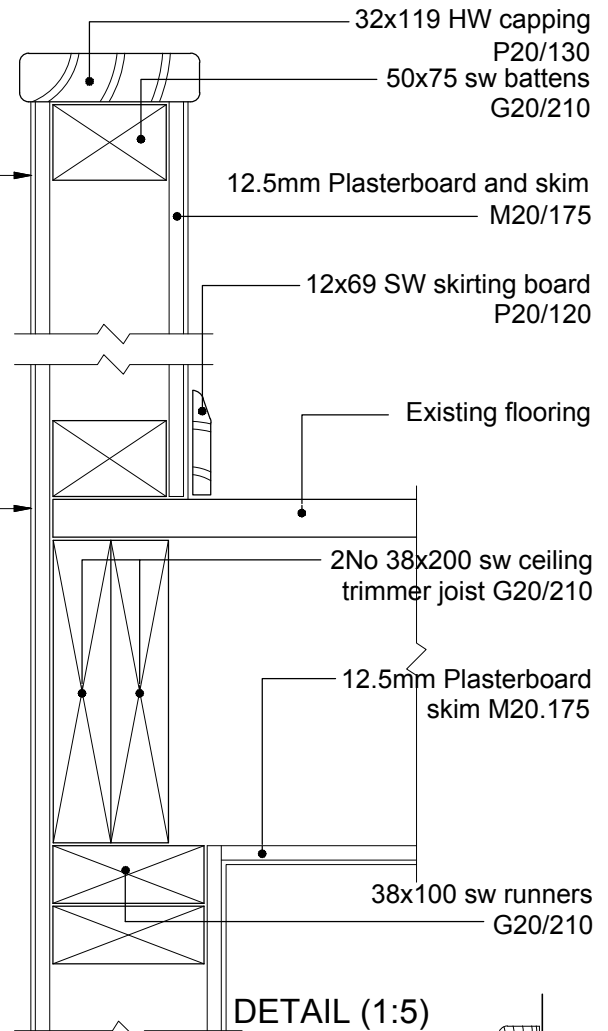

DETAIL (1:5)

9x27mm HW cover plate P20/130

12.5mm plasterboard as M20/175

25x20 sw grounds G20/210

32x269mm sw stringer as P20/120

9x27mm sw bead P20/120

DETAIL (1:5)

NOTES:

- Where possible, stairs are to comply with current Building Control Regulations, Technical Booklet H.
- Max. riser 220mm, min. going 220mm, max. pitch 42°.
- 2R(risers)+G(going) to be between 550 & 700mm.
- Where replacement stairs do not fit within available space either replace exactly 'like for like' or seek Building Control guidance.
- See drawing A(06.11)01 for Stair Plan & drawing A(06.11)02 for longitudinal cross section A-A
- Guarding rails to resist a horizontal force of 0.36kN/m.
- Guarding should be constructed so that a 100 mm diameter sphere cannot pass through any opening in it.

Spec Reference L30.270



TITLE	13 RISERS STRAIGHT FLIGHT STAIRCASE WITHIN EXISTING DWELLINGS (cross-section and details)	
-------	---	--

DRAWN BY	P&S	SCALE	1:5, 1:20	DATE	Apr 91
DRAWING NO.	A(06.11)04				
REV NO. & DATE	(6) 07/16				
REV NOTE:	Updated for Building Control				



119x32mm HW Handrail P20/130

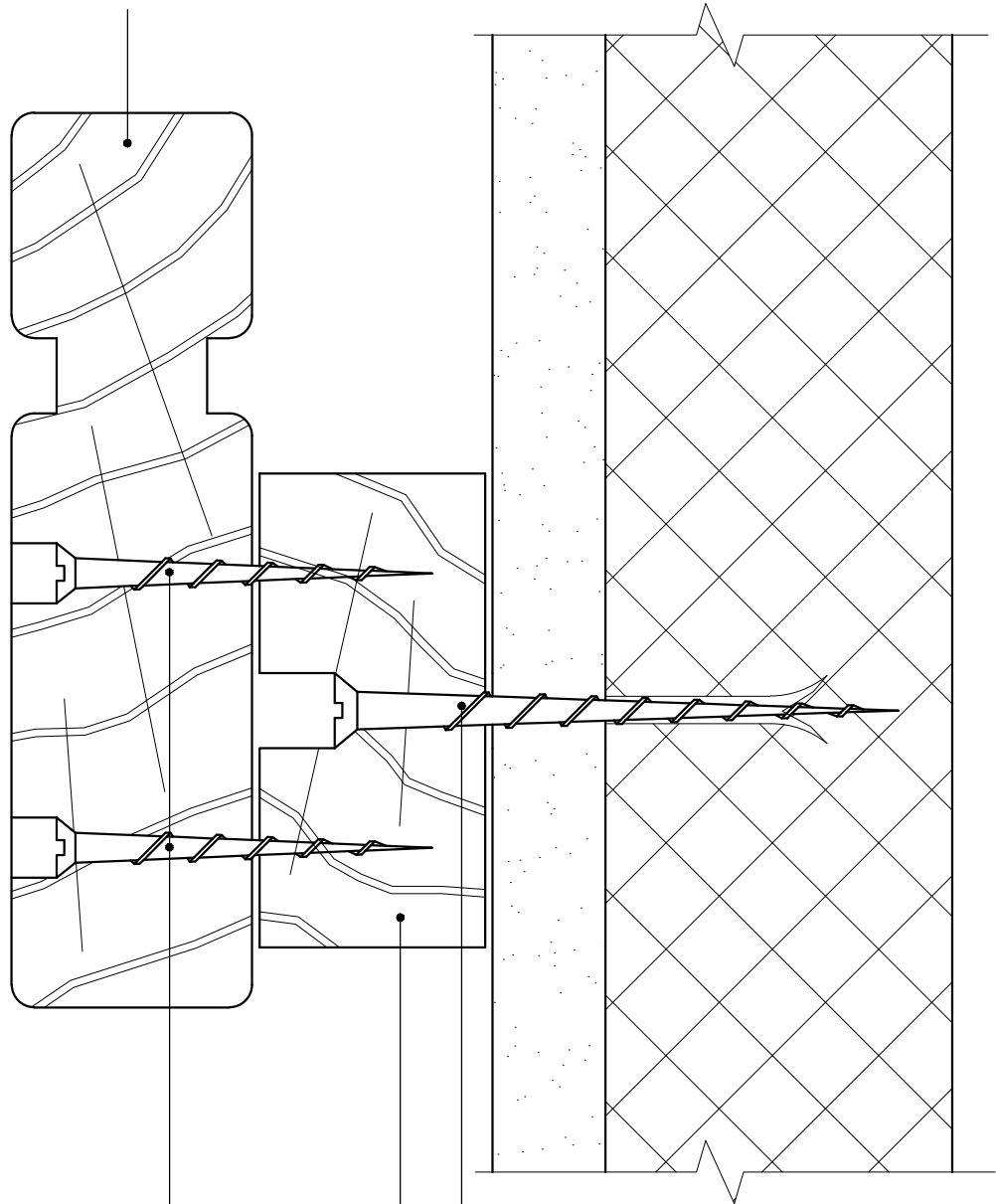

2No. 50mm No.8 screws

32x63mm SW Batten G20/270

75mm No.10 screw

HAND RAIL FIXING TO WALL SECTION

© NIHE 2017  
DRAWINGS NOT TO BE SCALED DUE TO PRINTING DISTORTION



TITLE

SECTION OF  
STAIRCASE  
HANDRAIL

DRAWN BY

TJB

SCALE

1:1

DATE

Apr 91

DRAWING NO.

A(06.11)13

REV NO. & DATE

(1) 9/94

REV NOTE:





\* This NIHE produced detail has been examined by The Building Control N.I. Standards Panel and has been considered reasonable in its interpretation of the relevant requirements of the Building Regulation NI 2012. There is no legal obligation for any Building Control department to adopt this recommendation & it is subject to revision in the event of changes to the legislation or other mitigating circumstances.

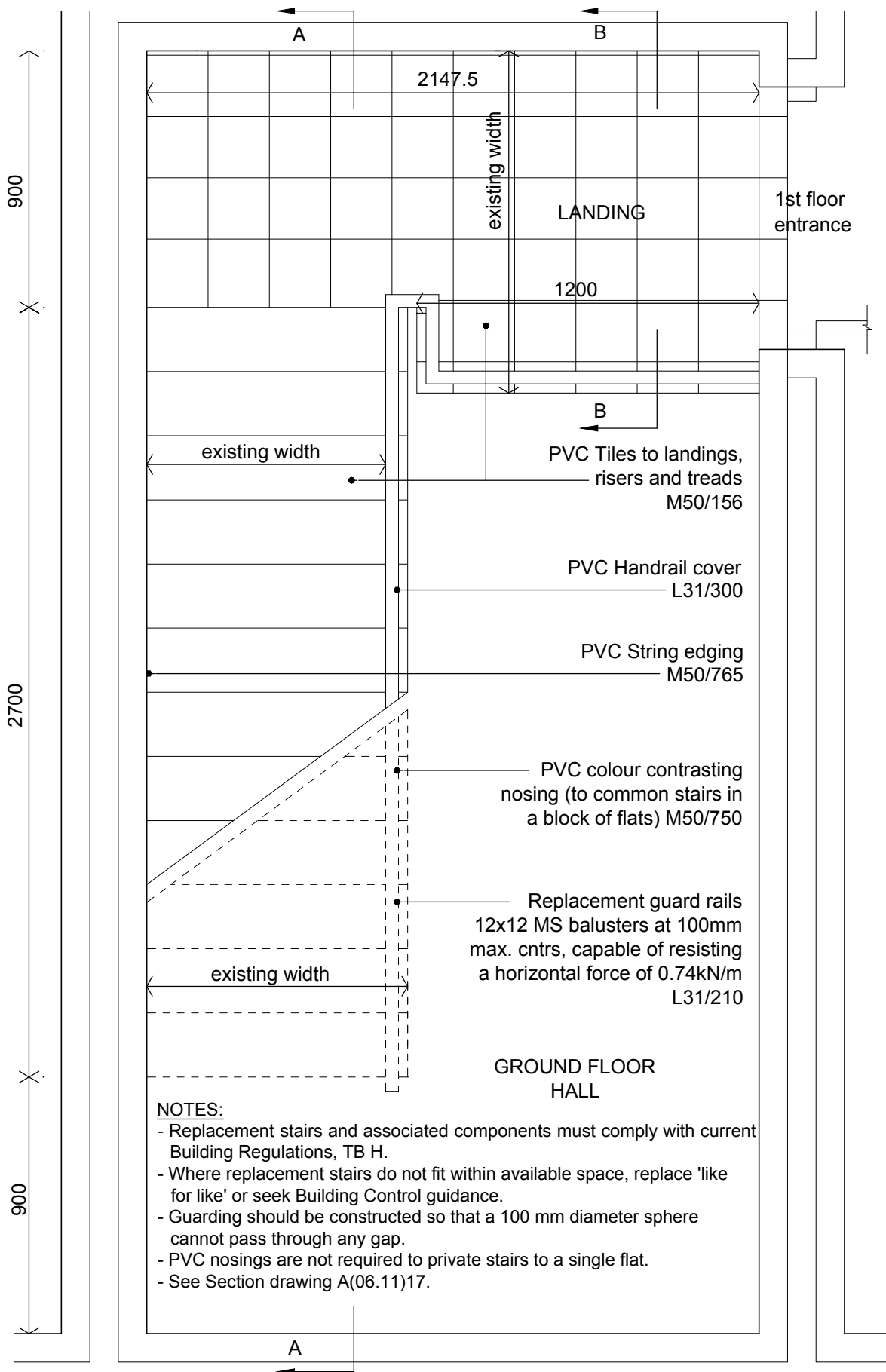

**NOTES:**

- Replacement stairs and associated components must comply with current Building Regulations, TB H.
- Where replacement stairs do not fit within available space, replace 'like for like' or seek Building Control guidance.
- Guarding should be constructed so that a 100 mm diameter sphere cannot pass through any gap.
- PVC nosings are not required to private stairs to a single flat.
- See Section drawing A(06.11)17.

© NIHE 2017

DRAWINGS NOT TO BE SCALED DUE TO PRINTING DISTORTION



**BCNI Standards  
Panel Agreed \***

TITLE  
**EXISTING INTERNAL  
STAIR TO FLATS - PLAN**

DRAWN BY <b>P&amp;S</b>	SCALE <b>1:20</b>	DATE <b>Apr 91</b>
DRAWING NO.	<b>A(06.11)16</b>	
REV NO. & DATE	<b>(6) 07/16</b>	
REV NOTE: Updated for Building Control		

\* This NIHE produced detail has been examined by The Building Control N.I. Standards Panel and has been considered reasonable in its interpretation of the relevant requirements of the Building Regulation NI 2012. There is no legal obligation for any Building Control department to adopt this recommendation & it is subject to revision in the event of changes to the legislation or other mitigating circumstances.

**NOTES:**

- Replacement stairs and associated components must comply with current Building Regulations, TB H.
- Where replacement stairs do not fit within available space, replace 'like for like' or seek Building Control guidance.
- Guarding should be constructed so that a 100 mm diameter sphere cannot pass through any gap.
- Replacement guard rails: 12x12 MS balusters at 100mm max. cntrs, capable of resisting a horizontal force of 0.74kN/m, L31/210
- PVC nosings are not required to private stairs to a single flat.
- See Plan drawing A(06.11)16.

**Housing Executive**  
 BCNI Standards Panel Agreed\*

**TITLE**  
 EXISTING INTERNAL STAIR  
 TO FLATS - SECTIONS

DRAWN BY <b>P&amp;S</b>	SCALE 1:20	DATE Apr 91
	DRAWING NO. A(06.11)17	
REV NO. & DATE (7) 07/16	REV NOTE: Updated for Building Control	

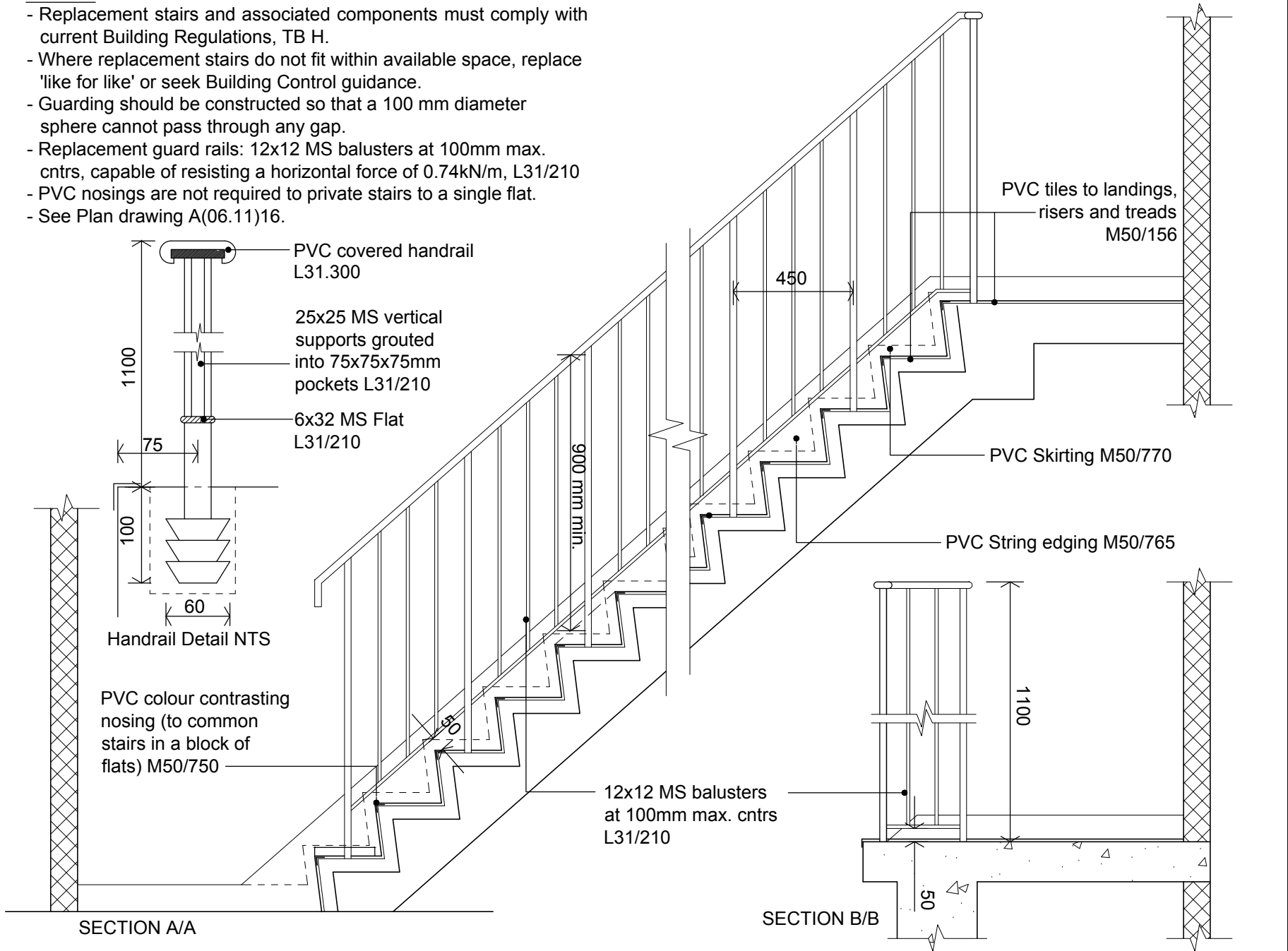

SECTION A/A

SECTION B/B

\* This NIHE produced detail has been examined by The Building Control N.I. Standards Panel and has been considered reasonable in its interpretation of the relevant requirements of the Building Regulation NI 2012. There is no legal obligation for any Building Control department to adopt this recommendation & it is subject to revision in the event of changes to the legislation or other mitigating circumstances.

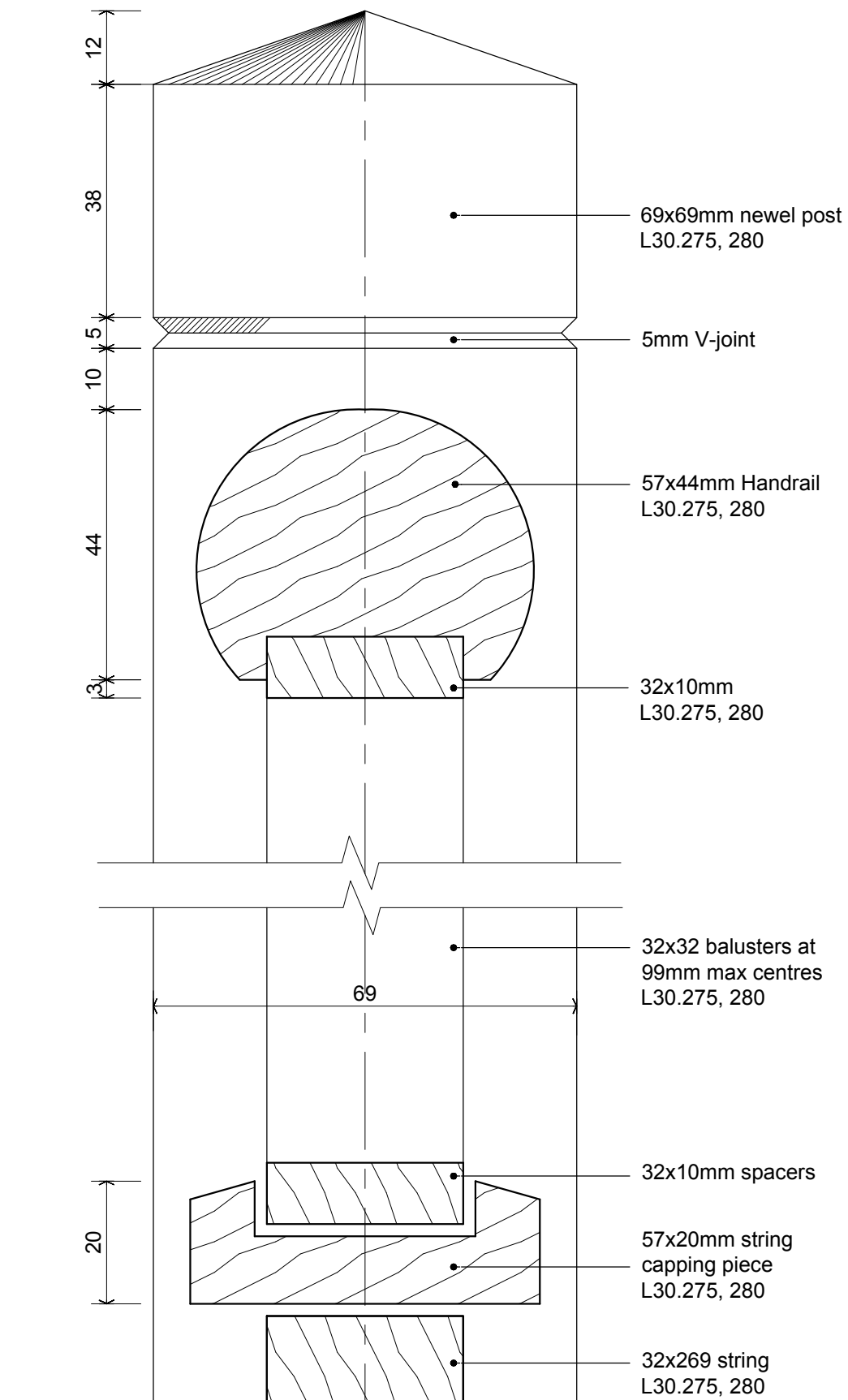

**NOTE:**

- Guarding rails to resist a min. horizontal force of 0.36 kN/m at a min. height of 900mm.
- Guarding should be constructed so that a 100 mm diameter sphere cannot pass through any opening in it.

**Housing Executive**

**BCNI Standards**  
**Panel Agreed \***

**TITLE**

**STANDARD NEWEL  
POST AND BALUSTRADE  
DETAIL WITHIN  
DWELLINGS**

**DRAWN BY**

**P&S**

**SCALE**

**1:1**

**DATE**

**Sept 94**

**DRAWING NO.**

**A(06.11)19**

**REV NO. & DATE**

**(3) 12/14**

**REV NOTE:**

**Updated for Building Control**



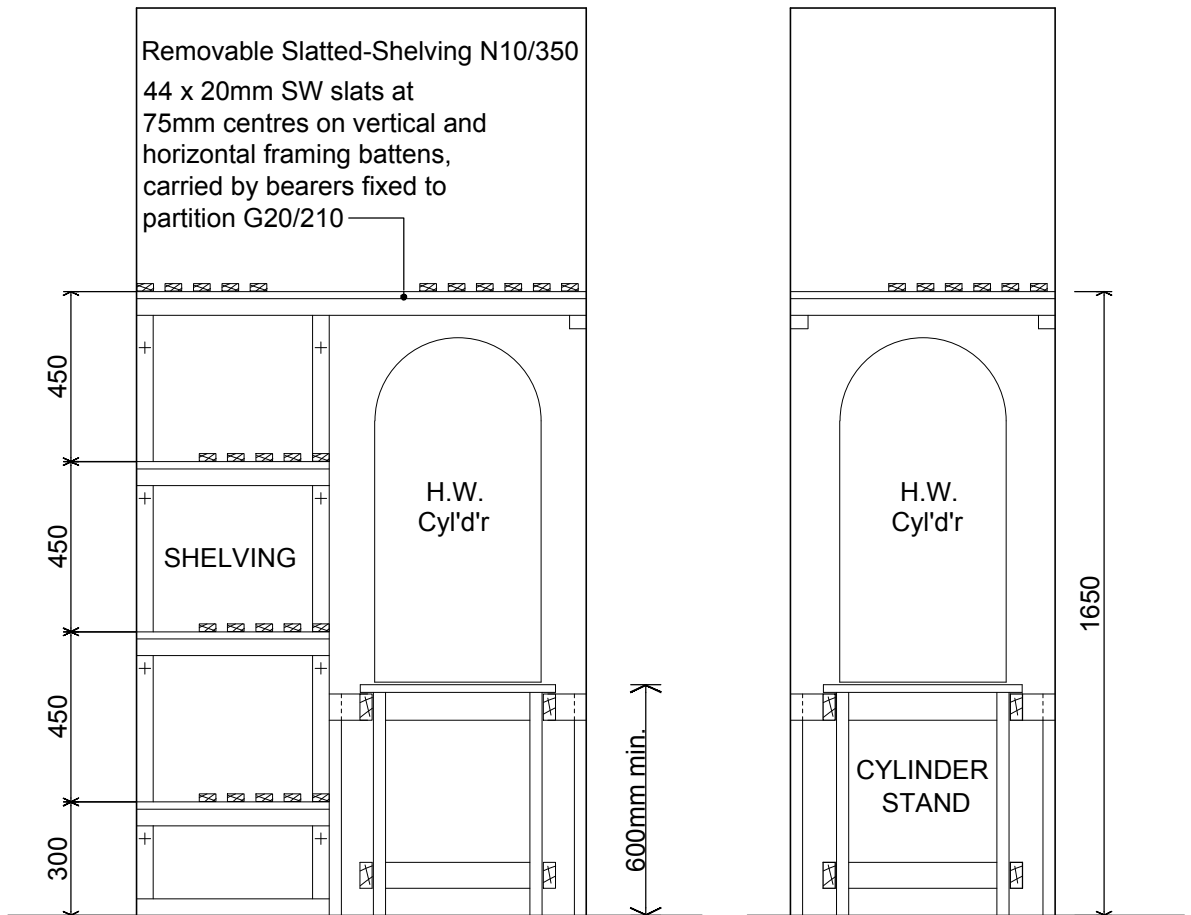

**TYPICAL SECTIONS THROUGH HOT PRESS TYPES**

NOTE: Single-storey dwellings with solid-fuel fires to have HW Cylinder placed on stand above finished floor level

Stand with 69x69 SW legs and 32x69 SW runners G20/210 with 19mm plywood platform top G20/310

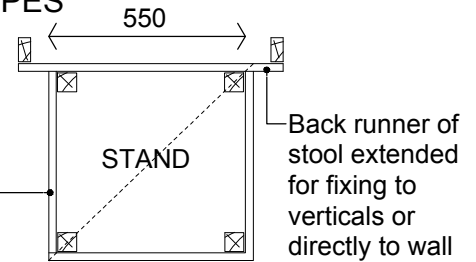

**PLAN of CYLINDER STAND**

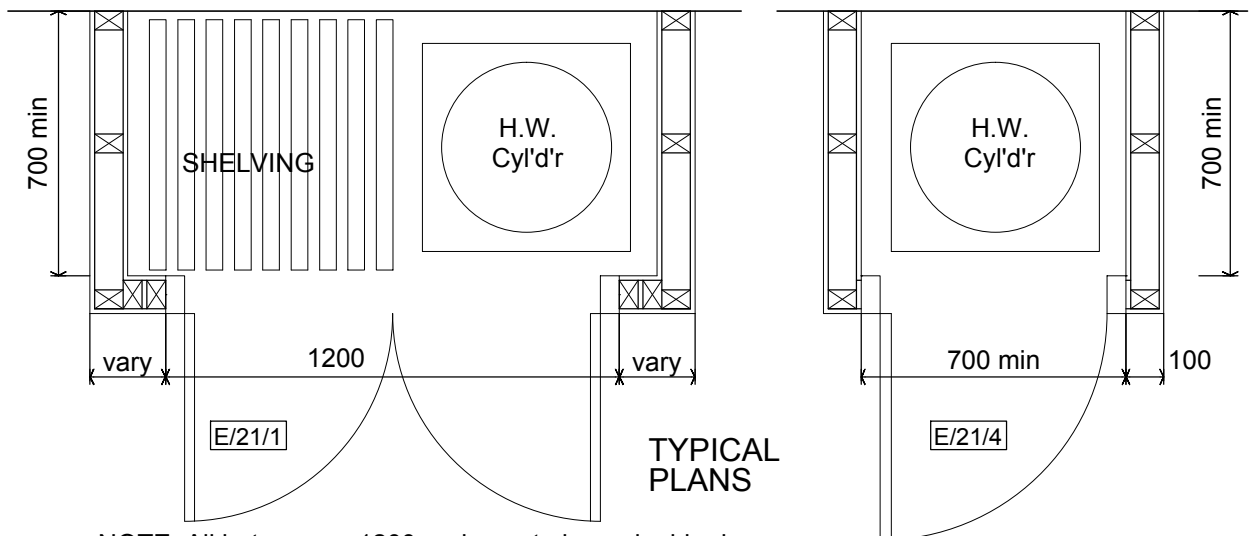

**TYPICAL PLANS**

NOTE: All hotpresses 1200 and over to have double doors



TITLE  
**HOT-PRESS CUPBOARD  
 INDIRECT CYLINDER  
 STAND AND SHELVING  
 (FOR SINGLE-STOREY  
 DWELLINGS)**  
 Typical Arrangements

DRAWN BY TJB/CgR/CB	SCALE 1:20	DATE Apr 91
DRAWING NO.	A(06.12)01	
REV NO. & DATE	(4) 09/12	
REV NOTE: Updated to revised spec		



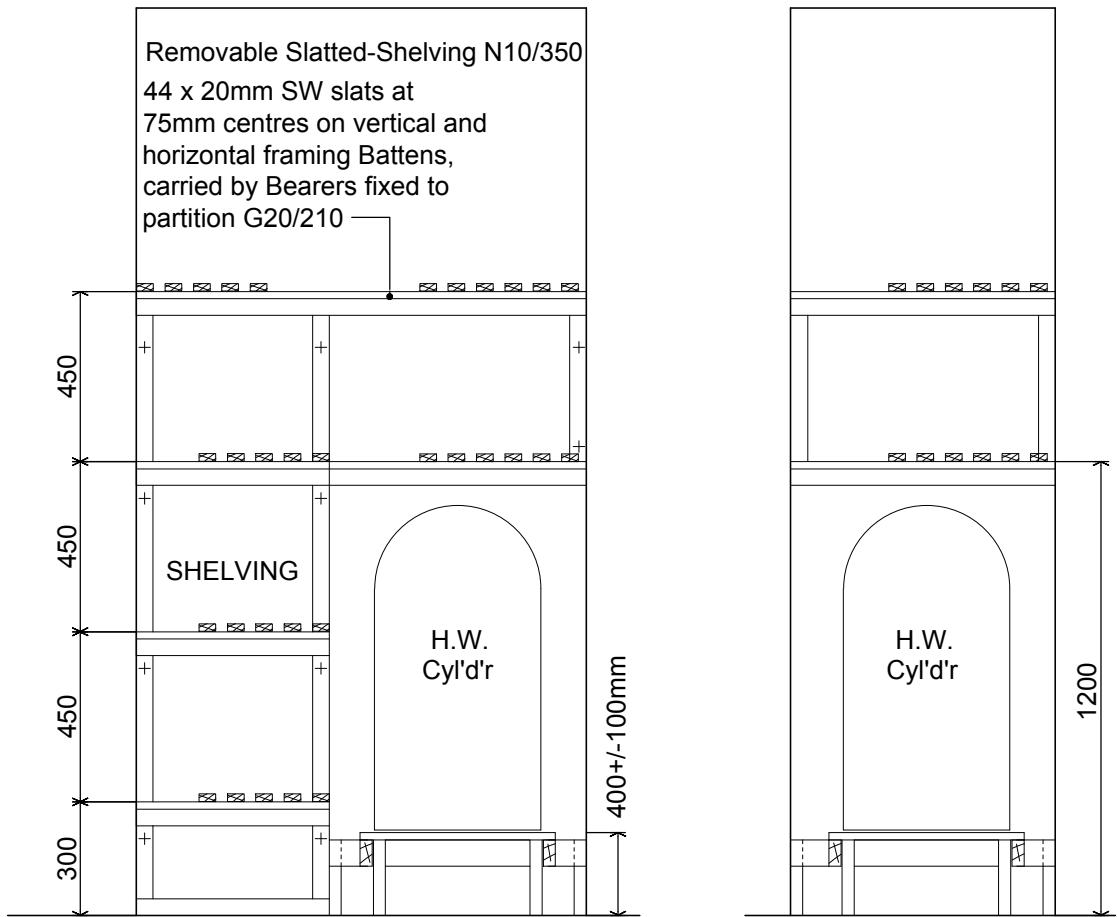

TYPICAL SECTIONS THRO' HOT PRESS TYPES

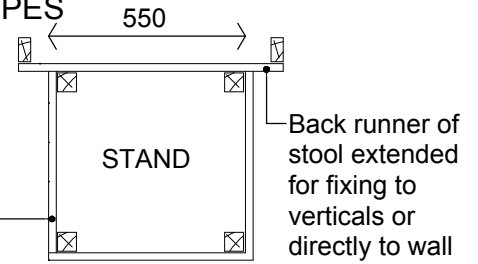

PLAN of CYLINDER STAND

Stand with 69x69 SW legs and 32x69 SW runners G20/210 with 19mm plywood platform top G20/310

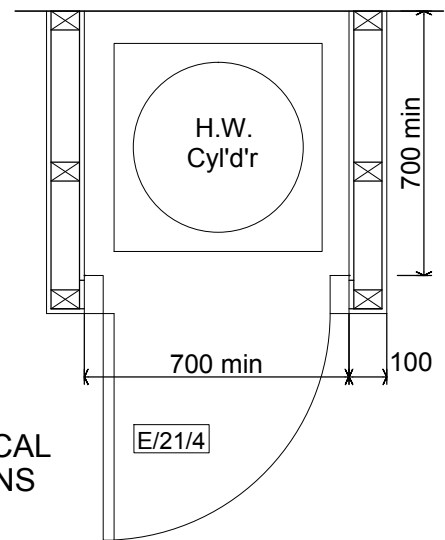
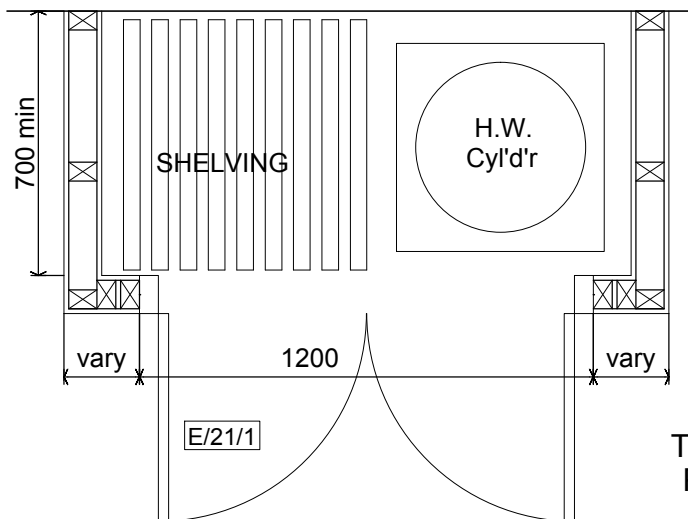

TYPICAL PLANS

NOTE: All hotpresses 1200 and over to have double doors

© NIHE 2017 DRAWINGS NOT TO BE SCALED DUE TO PRINTING DISTORTION



TITLE  
HOT-PRESS CUPBOARD  
INDIRECT CYLINDER  
STAND AND SHELVING  
(FOR TWO-STOREY  
DWELLINGS)  
Typical Arrangements

DRAWN BY TJB/CgR/CB	SCALE 1:20	DATE Apr 91
DRAWING NO.	A(06.12)02	
REV NO. & DATE	(4) 09/12	
REV NOTE: Updated to revised spec		

© NIHE 2017  
 DRAWINGS NOT TO BE SCALED DUE TO PRINTING DISTORTION

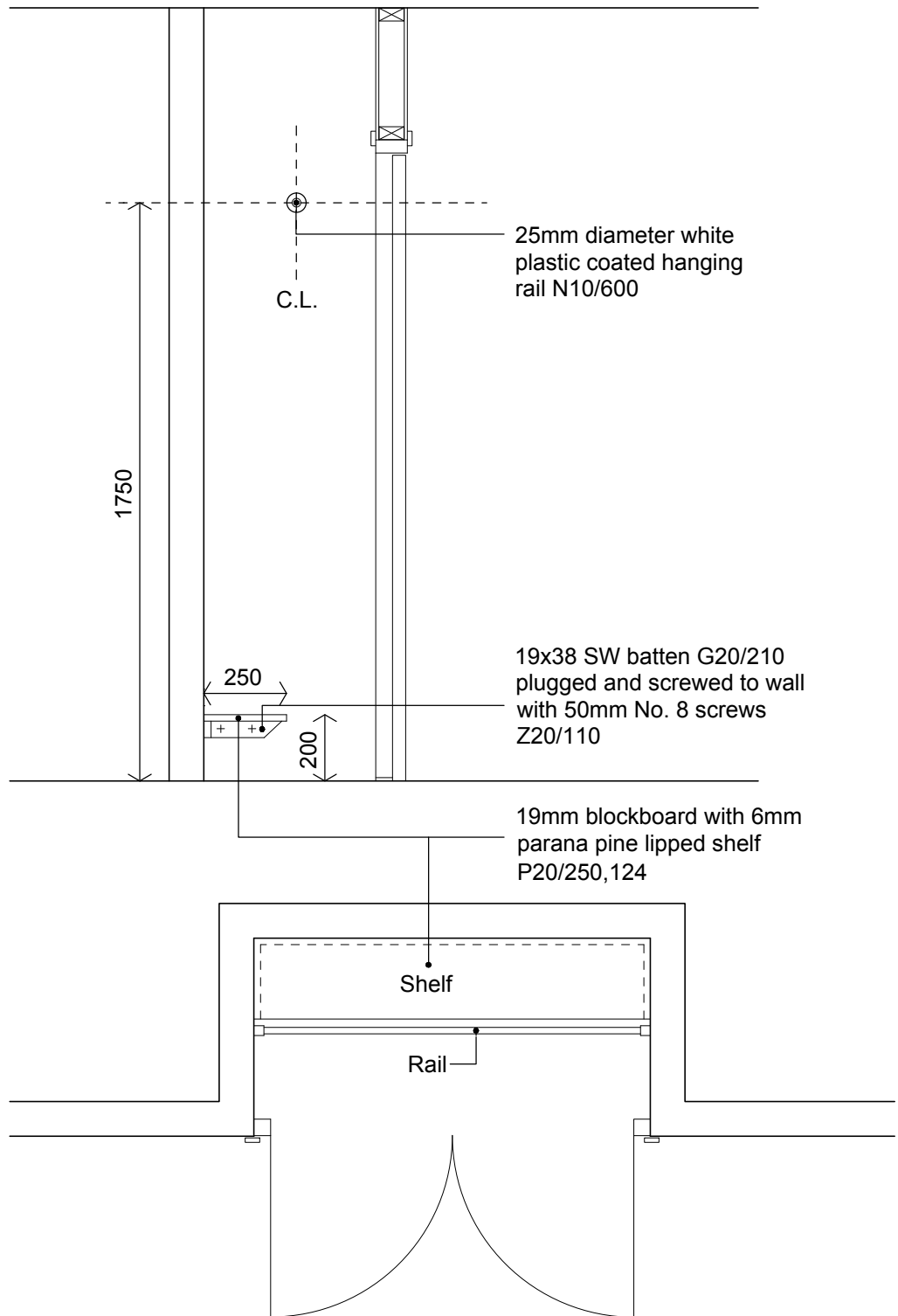

TITLE  
**STANDARD WARDROBE  
 RAIL AND SHELF  
 DETAIL**

DRAWN BY <b>TLB</b>	SCALE <b>1:20</b>	DATE <b>Apr 91</b>
DRAWING NO.	<b>A(06.12)06</b>	
REV NO. & DATE	<b>(1) 9/99</b>	
REV NOTE:		



**Housing**  
Executive

NB: All dims are approximate, units to be sized to fit existing back panel. Units 600mm wide and under to have a single door. Units over 600mm to have double doors. Overall height min. 900mm. Carcass to be dowelled and glued. SW timber to be painted as M60/182 before construction.

TITLE  
**ELECTRICAL METER CUPBOARD**  
STANDARD  
(Not suitable for protected stairways to 3 storey dwellings or communal areas)

REV NO. & DATE (1) 04/13	DRAWING NO. A(06.13)04	SCALE 1:10	DATE Nov 12
REV NOTE: Title, construction, workmanship and lock	DRAWN BY CB		

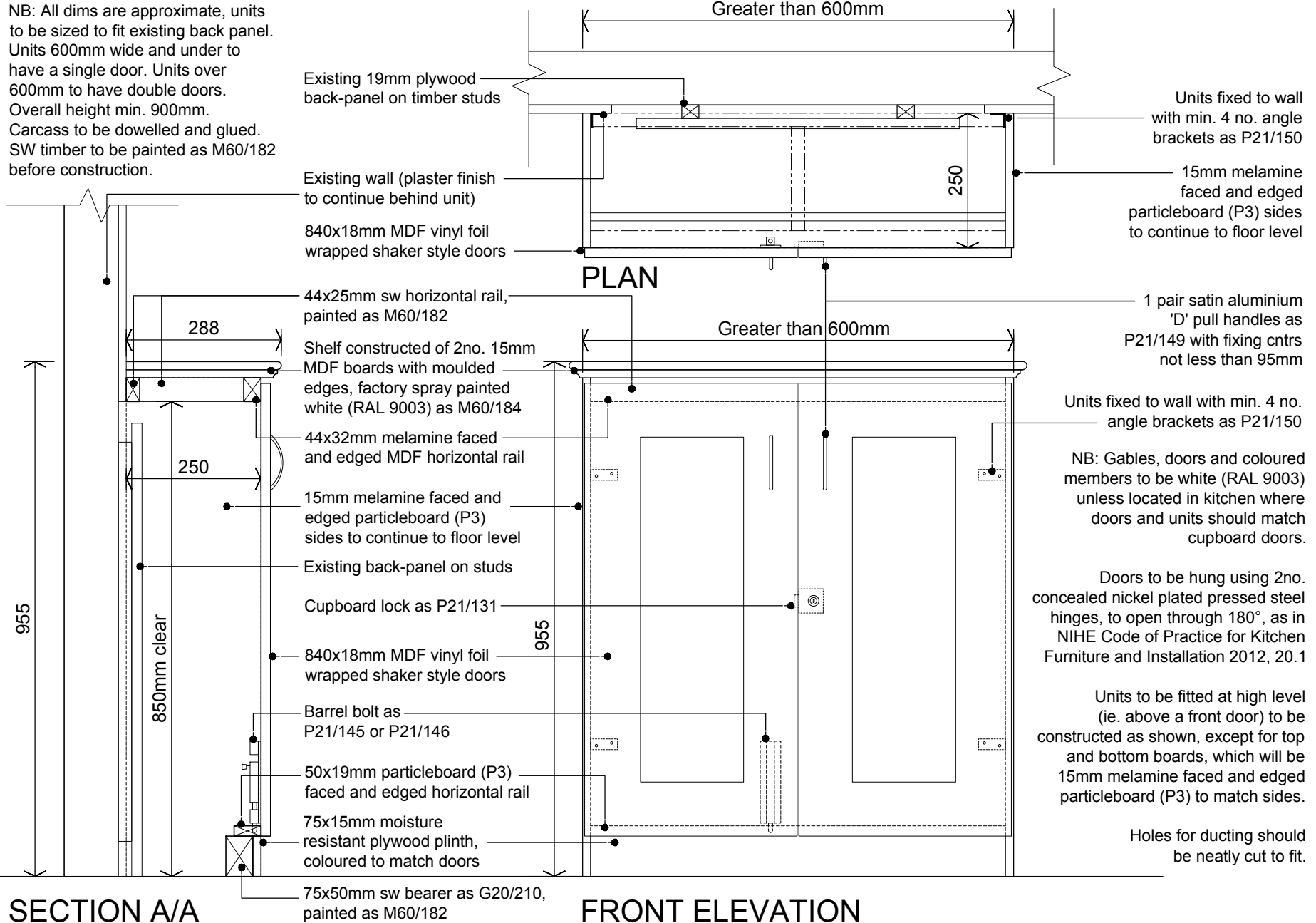

**SECTION A/A**

**FRONT ELEVATION**

SPECIFICATION REFERENCES: N10/102, 103 and NIHE Code of Practice for Kitchen Furniture and Installation 2012



**Housing**  
Executive

NB: All dims are approximate, units to be sized to fit existing back panel. Units 600mm wide and under to have a single door and units over 600mm to have double doors. Overall height min. 900mm. Carcass to be dowelled and glued. SW timber to be painted as M60/182 before construction. This drawing does not represent a complete fire resistant cupboard. If one is required see clause N10.107

Existing wall (plaster finish to continue behind cupboard)  
Existing back-panel on studs  
Fire retardant sealant as Z22.116 to be applied to joint between unit and existing wall  
Existing wall (plaster finish to continue behind unit)  
840x18mm FR MDF shaker style doors

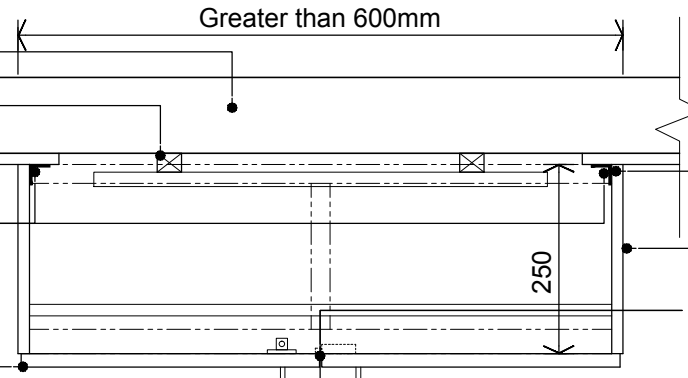

Units fixed to wall with min. 4 no. angle brackets as P21/150  
15mm FR MDF sides to continue to floor level  
L20.404 Intumescent Combined Smoke Seal  
1 pair satin aluminium 'D' pull handles as P21/149 with fixing cntrs not less than 95mm

44x25mm sw horizontal rail, painted with fire retardant paint as M60/258  
Shelf constructed of 2no. 15mm boards of FR MDF, with moulded edges  
44x32mm FR MDF horizontal rail  
Existing back-panel on studs  
15mm FR MDF sides to continue to floor level  
Cupboard lock as P21/131  
840x18mm FR MDF shaker style doors  
Barrel bolt as P21/145 or P21/146  
Units fixed to wall with min. 4 no. angle brackets as P21/150  
50x18mm FR MDF horizontal rail  
75x15mm FR MDF  
75x50mm sw bearer as G20/210, painted with fire retardant paint as M60/258

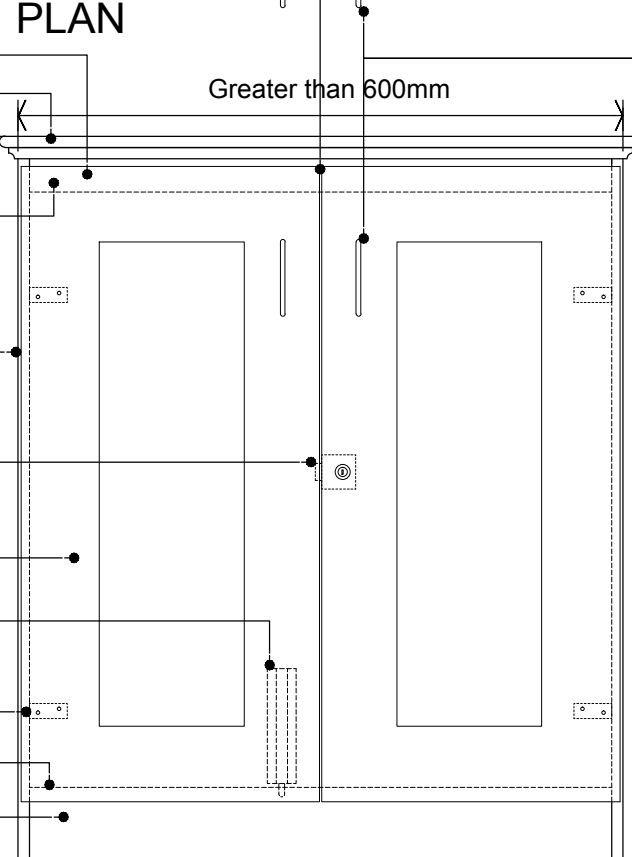

NB: All MDF to be fire retardant (FR) and to be factory spray painted white (RAL 9003) with fire retardant paint as M60/258

Doors to be hung using 2no. concealed nickel plated pressed steel hinges, to open through 180° as in NIHE Code of Practice for Kitchen Furniture and Installation 2012, 20.1

Units to be fitted at high level (ie. above a front door) to be constructed as shown, except for top and bottom boards, which will be 15mm fire retardant MDF, painted as above.

Holes for ducts should be neatly cut to fit. Small gaps should be filled using fire retardant sealant as Z22.116 and large gaps should be filled using fire retardant expanding foam as P10.710.

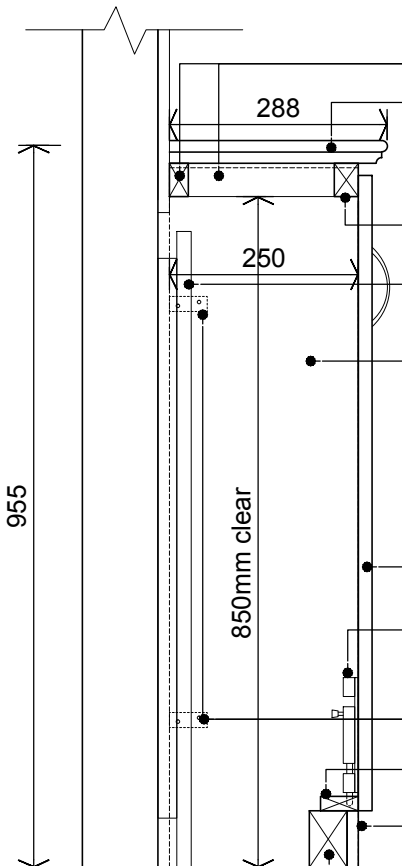

**SECTION A/A**

NOTE: min. 30min FR required.

**FRONT ELEVATION**

SPECIFICATION REFERENCES:  
N10/105, 106 and NIHE Code of Practice for Kitchen Furniture and Installation 2012

TITLE  
**ELECTRICAL METER CUPBOARD**  
Fire Retardant MDF  
(Suitable for meter cupboard replacement only, to protect stairways of 3 storey dwellings and communal areas)

DRAWING NO. A(06.13)05	SCALE 1:10	DATE Nov 12
	REV NO. & DATE (1) 04/13	
REV NOTE: Title, construction, workmanship and lock		





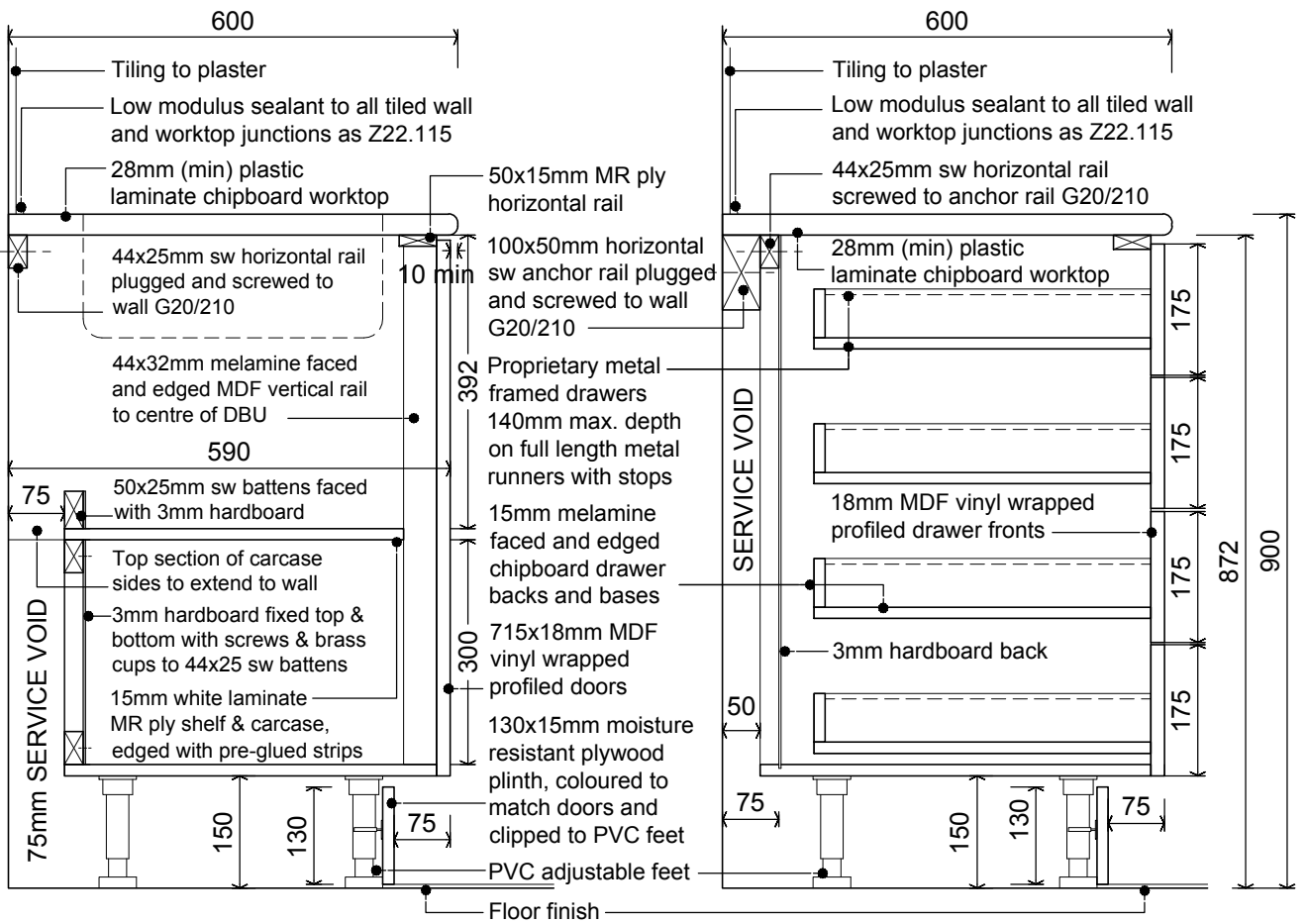

SECTION: 10DB/SU (sink unit)

SECTION: 5SB/DU (drawer unit)

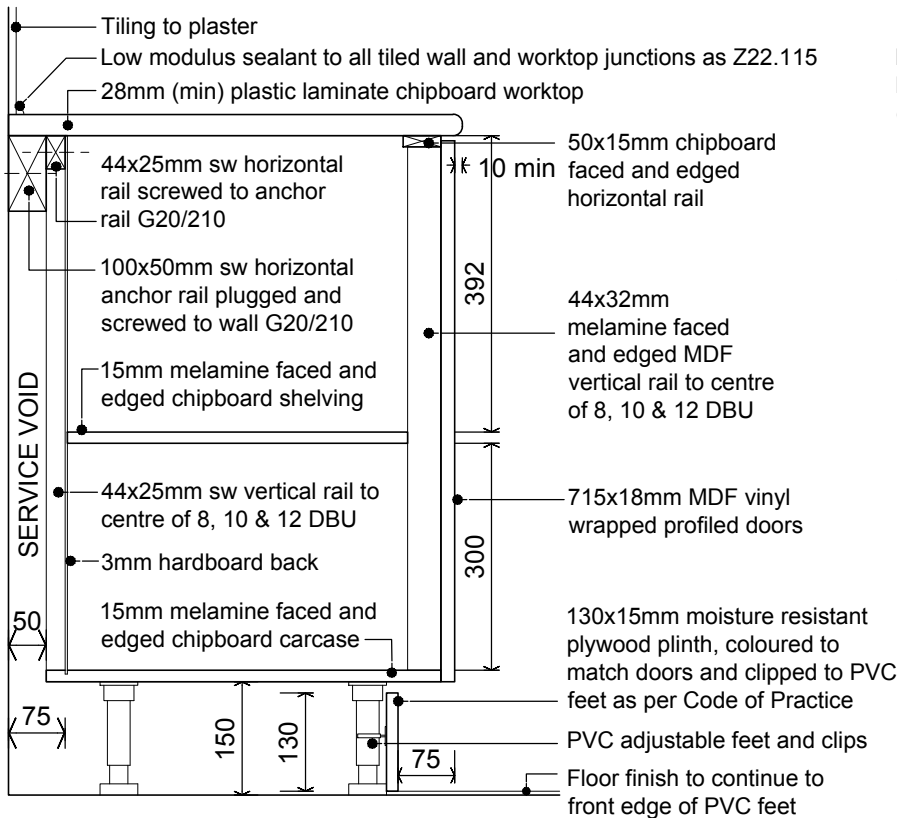

SECTION: 8,10&12 DBU (cupboard base unit)

NB: Moisture resistant (MR) plywood to be faced in high pressure laminate and edged with pre-glued strips

REFERENCES:

1. FOR SCHEDULE OF SYMBOLS SEE S(07.10)01
2. NIHE CODE OF PRACTICE N11 KITCHEN FURNITURE AND INSTALLATION
3. SEE SPECIFICATION CLAUSE N11/153

© NIHE 2017 DRAWINGS NOT TO BE SCALED DUE TO PRINTING DISTORTION



<p>TITLE FIXTURES AND FITTINGS</p> <p>STANDARD RANGE KITCHEN BASE UNITS</p> <p>TYPICAL SECTIONS</p>	<p>DRAWN BY P&amp;S</p>	<p>SCALE 1:10</p>	<p>DATE Aug 90</p>
	<p>DRAWING NO. C(07.10)01</p>		
	<p>REV NO. &amp; DATE (11) 06/16</p>		
	<p>REV NOTE: 15mm thk. horizontal front rail</p>		



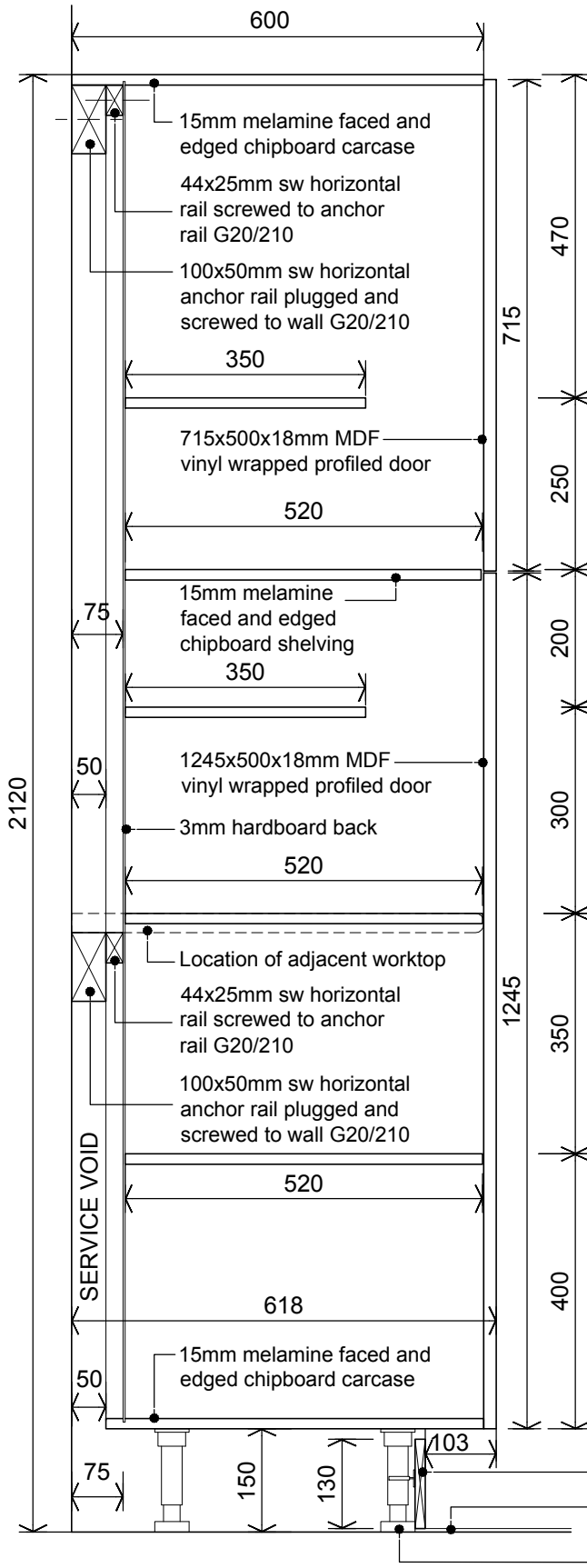

REFERENCES:

1. FOR SCHEDULE OF SYMBOLS SEE S(07.10)01
2. NIHE CODE OF PRACTICE N11 KITCHEN FURNITURE AND INSTALLATION
3. SEE SPECIFICATION CLAUSE: N11/153

NB: Visible side of tall unit carcass to be coloured to match doors

130x15mm moisture resistant plywood plinth, coloured to match doors and clipped to PVC feet as per Code of Practice

Floor finish to continue to front edge of PVC feet

PVC adjustable feet and clips

SECTION: 5 STU (single tall unit)

© NIHE 2017 DRAWINGS NOT TO BE SCALED DUE TO PRINTING DISTORTION



TITLE  
FIXTURES AND FITTINGS

STANDARD RANGE  
KITCHEN TALL UNIT

TYPICAL SECTION

DRAWN BY  
TJB/CgR/CB

SCALE  
1:10

DATE  
Aug 90

DRAWING NO.

C(07.10)02

REV NO. & DATE

(6) 8/12

REV NOTE:

Updated to revised CoP



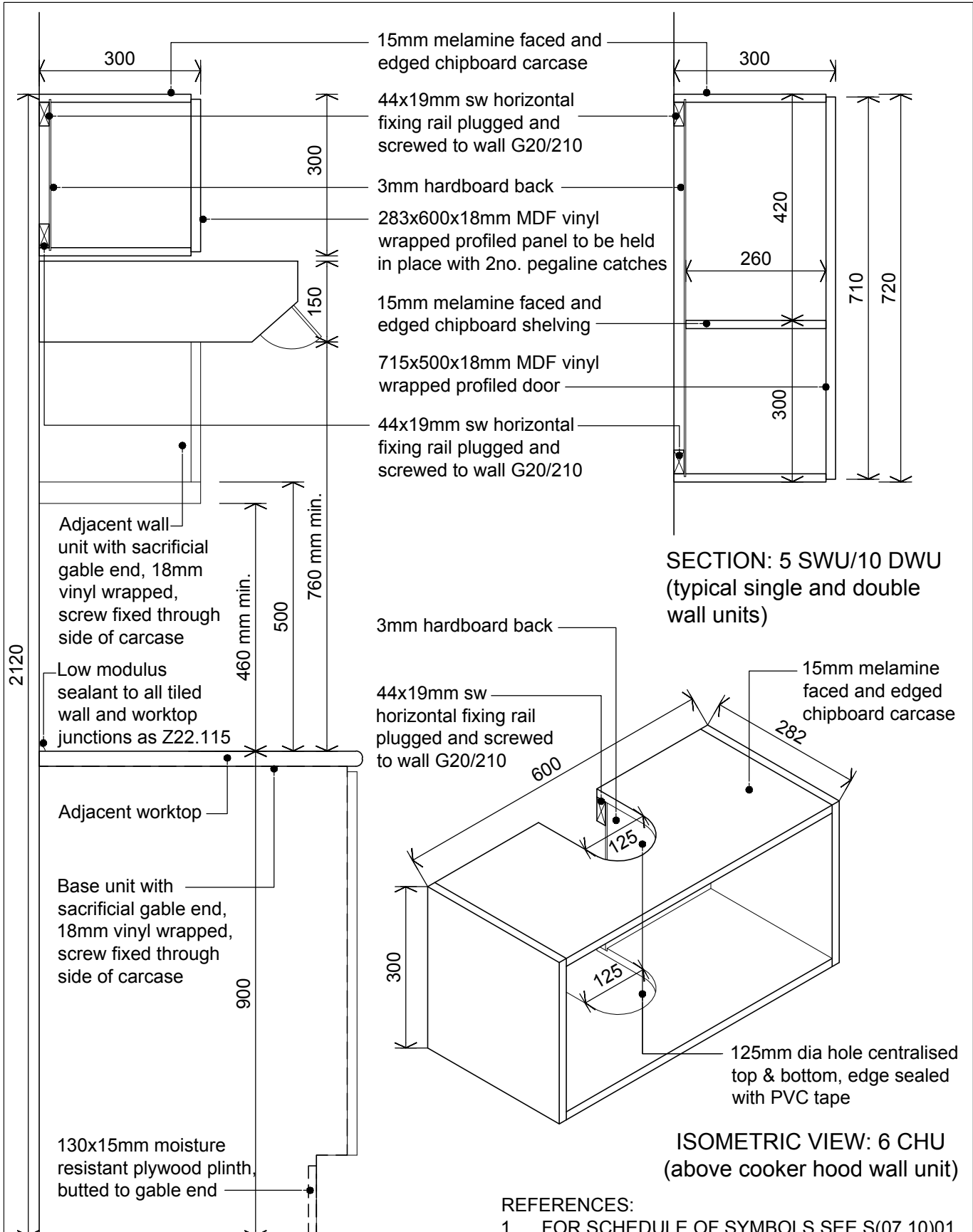

**SECTION: 6 CHU**  
(above cooker hood wall unit)

**SECTION: 5 SWU/10 DWU**  
(typical single and double wall units)

**ISOMETRIC VIEW: 6 CHU**  
(above cooker hood wall unit)

- REFERENCES:
1. FOR SCHEDULE OF SYMBOLS SEE S(07.10)01
  2. NIHE CODE OF PRACTICE N11 KITCHEN FURNITURE AND INSTALLATION
  3. SEE SPECIFICATION CLAUSE: N11/153

© NIHE 2017  
DRAWINGS NOT TO BE SCALED DUE TO PRINTING DISTORTION



TITLE  
**FIXTURES AND FITTINGS**

STANDARD RANGE  
KITCHEN WALL UNITS

TYPICAL SECTIONS

DRAWN BY <b>P&amp;S</b>	SCALE <b>1:10</b>	DATE <b>Aug 90</b>
DRAWING NO.	<b>C(07.10)03</b>	
REV NO. & DATE	<b>(7) 10/14</b>	
REV NOTE:	<b>Dimensions &amp; shelf height amendment</b>	



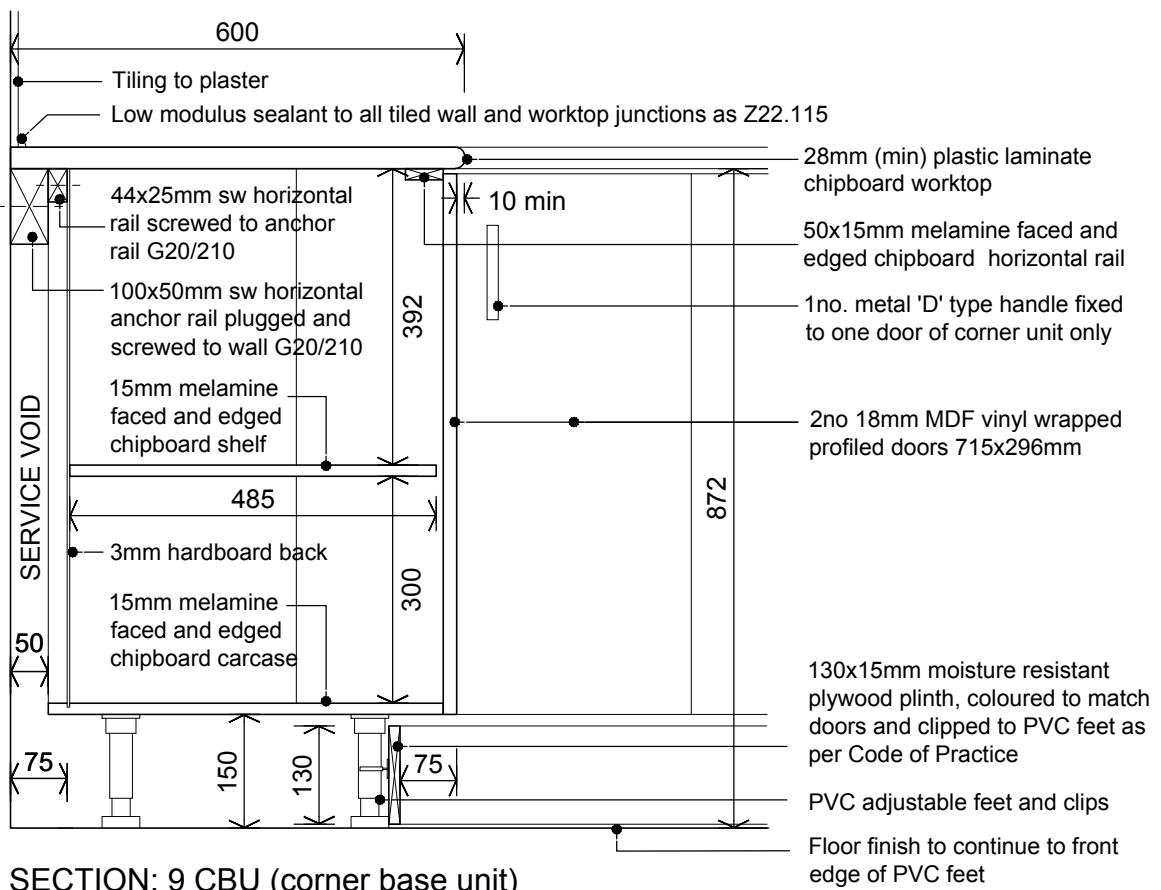

SECTION: 9 CBU (corner base unit)

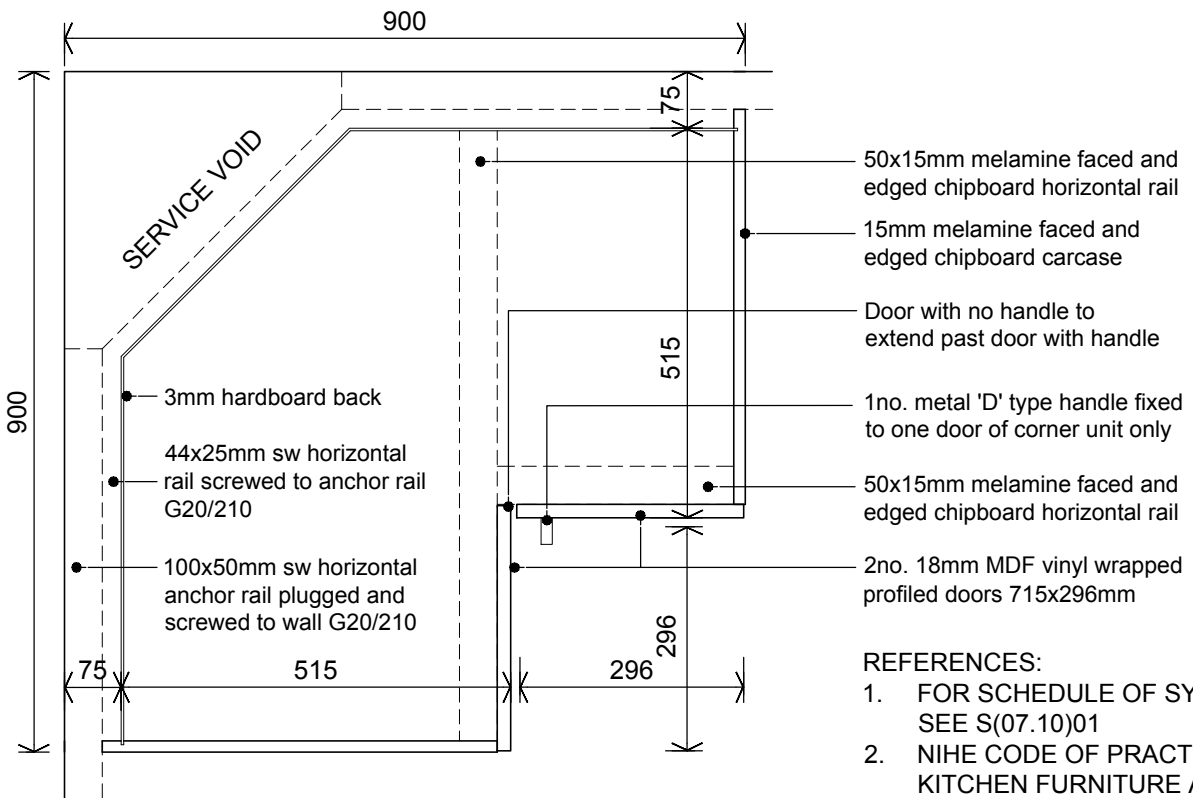

PLAN: 9 CBU (corner base unit)

130x15mm moisture resistant plywood plinth, coloured to match doors and clipped to PVC feet as per Code of Practice

PVC adjustable feet and clips

Floor finish to continue to front edge of PVC feet

50x15mm melamine faced and edged chipboard horizontal rail

15mm melamine faced and edged chipboard carcass

Door with no handle to extend past door with handle

1no. metal 'D' type handle fixed to one door of corner unit only

50x15mm melamine faced and edged chipboard horizontal rail

2no. 18mm MDF vinyl wrapped profiled doors 715x296mm

REFERENCES:

1. FOR SCHEDULE OF SYMBOLS SEE S(07.10)01
2. NIHE CODE OF PRACTICE N11 KITCHEN FURNITURE AND INSTALLATION
3. SEE SPECIFICATION CLAUSE: N11/153

© NIHE 2017 DRAWINGS NOT TO BE SCALED DUE TO PRINTING DISTORTION



TITLE  
**FIXTURES AND FITTINGS**

STANDARD RANGE KITCHEN  
 9 CBU CORNER BASE UNIT

TYPICAL PLAN & SECTION

DRAWN BY <b>P&amp;S</b>	SCALE <b>1:10</b>	DATE <b>Sept 94</b>
DRAWING NO.	<b>C(07.10)04</b>	
REV NO. & DATE	<b>(8) 07/16</b>	
REV NOTE: 15mm thk. horizontal front rail		



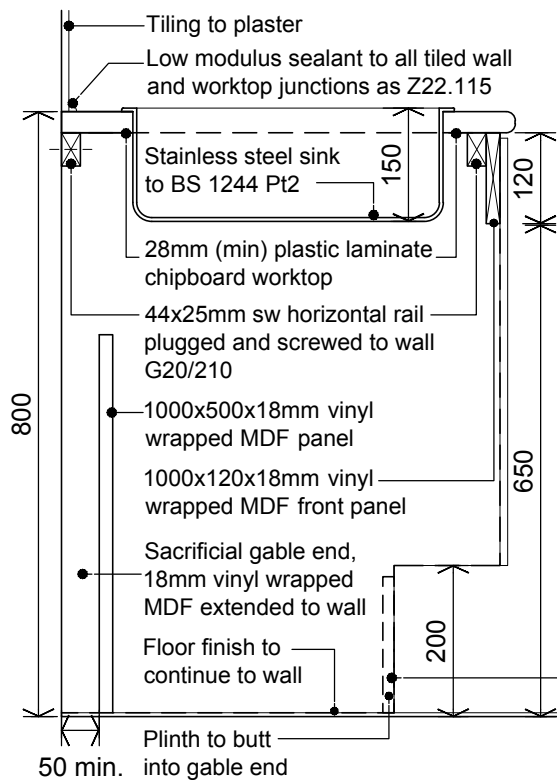

**SINK WORKTOP SECTION**

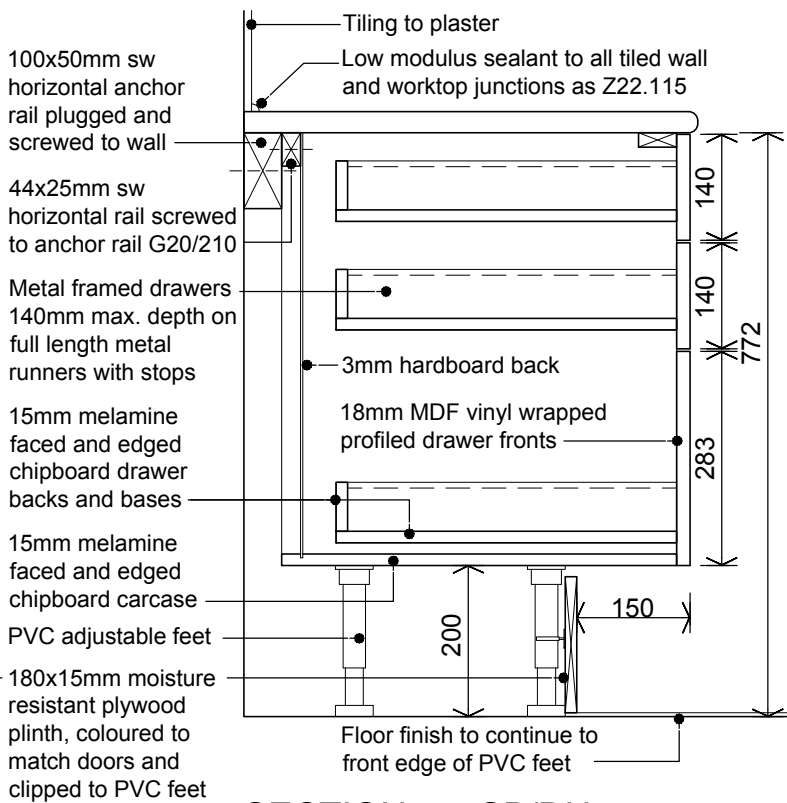

**SECTION: 5 uSB/DU  
(universal use drawer unit)**

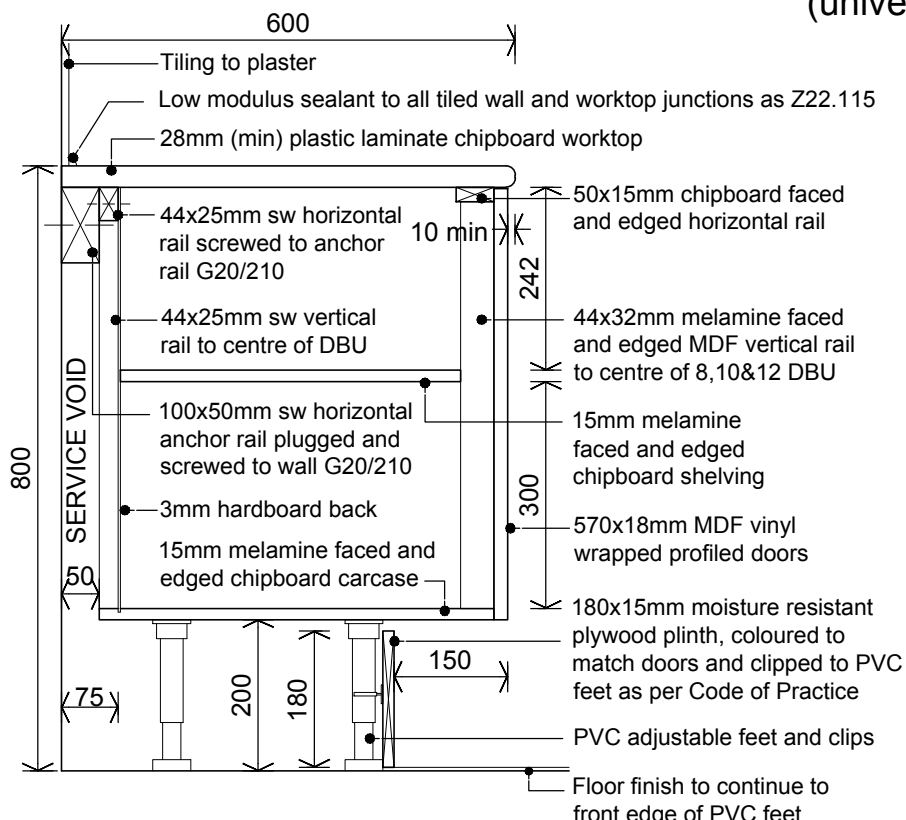

**SECTION: 5 uSBU & 8,10&12 uDBU  
(universal use single & double base units)**

- REFERENCES:**
1. FOR SCHEDULE OF SYMBOLS SEE S(07.10)01
  2. NIHE CODE OF PRACTICE N11 KITCHEN FURNITURE AND INSTALLATION
  3. SEE SPECIFICATION CLAUSE REFERENCES: N11/163
  4. TENANTS' OCCUPATIONAL THERAPIST TO BE INVOLVED IN KITCHEN DESIGN. DETAILS ARE GUIDANCE ONLY.

© NIHE 2017 DRAWINGS NOT TO BE SCALED DUE TO PRINTING DISTORTION



<b>TITLE</b> FIXTURES AND FITTINGS (UNIVERSAL USE RANGE)  KITCHEN WORKTOP DRAWER AND BASE UNITS TYPICAL SECTIONS	<b>DRAWN BY</b> P&S	<b>SCALE</b> 1:10	<b>DATE</b> Sept 00
	<b>DRAWING NO.</b>	C(07.10)05	
	<b>REV NO. &amp; DATE</b>	(6) 07/16	
	<b>REV NOTE:</b> 15mm thk. horizontal front rail		

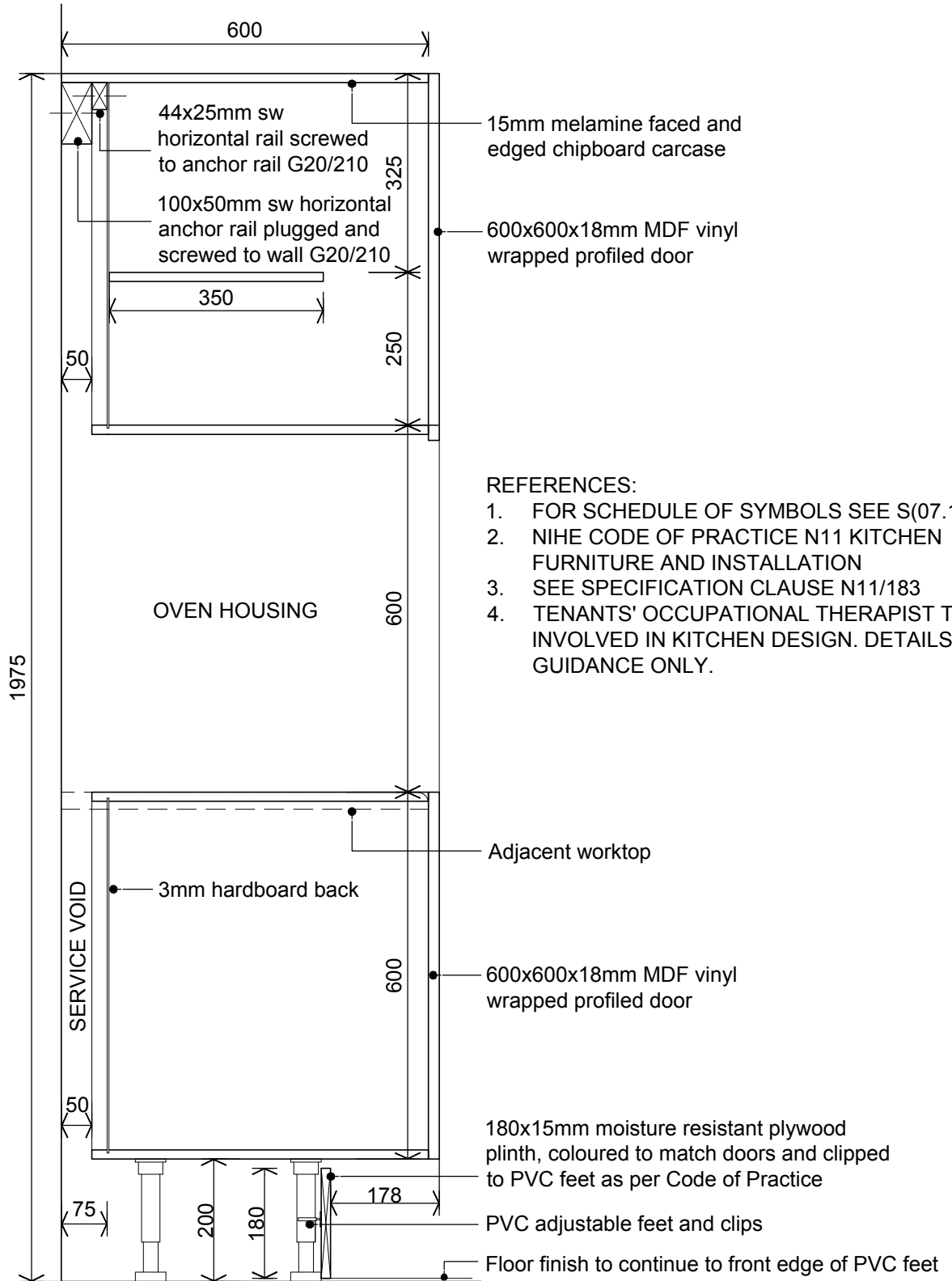

**SECTION: 6 uOHU**  
(universal use oven housing unit)

© NIHE 2017  
DRAWINGS NOT TO BE SCALED DUE TO PRINTING DISTORTION



TITLE <b>FIXTURES AND FITTINGS</b> (UNIVERSAL USE RANGE )  6 uOHU  OVEN HOUSING UNIT	DRAWN BY <b>TJB/CgR/CB</b>	SCALE <b>1:10</b>	DATE <b>Sept 00</b>
	DRAWING NO. <b>C(07.10)06</b>		
	REV NO. & DATE <b>(4) 08/12</b>		
	REV NOTE: <b>Updated to revised CoP</b>		

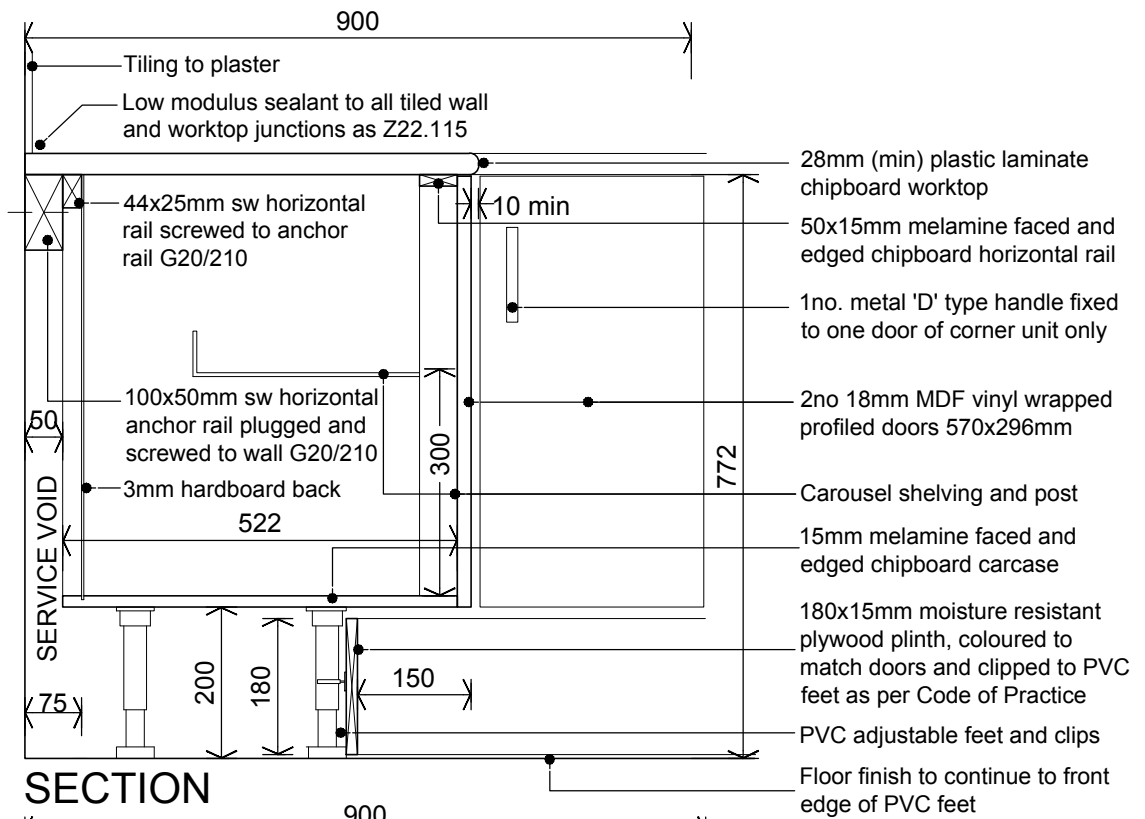

**SECTION**

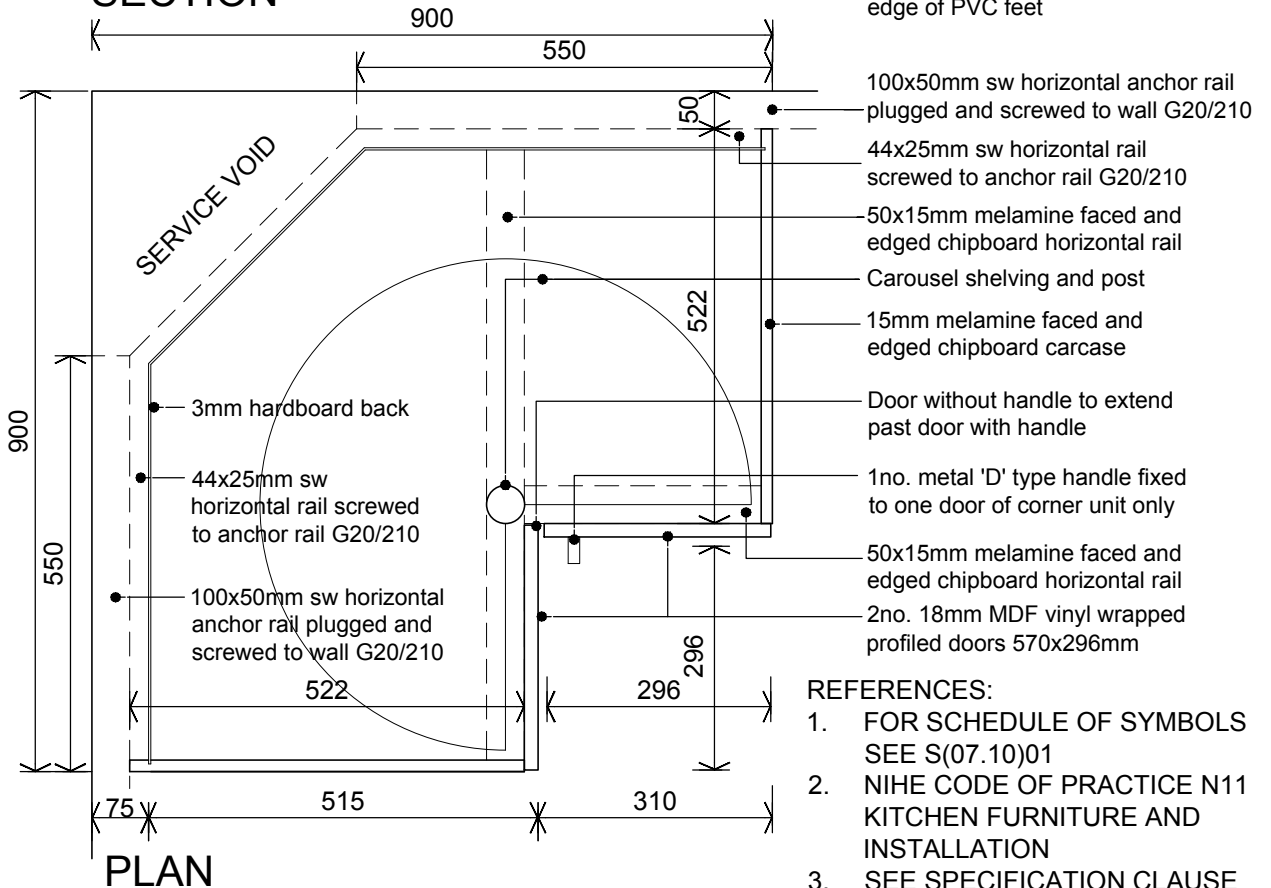

**PLAN**

- 28mm (min) plastic laminate chipboard worktop
- 50x15mm melamine faced and edged chipboard horizontal rail
- 1no. metal 'D' type handle fixed to one door of corner unit only
- 2no 18mm MDF vinyl wrapped profiled doors 570x296mm
- Carousel shelving and post
- 15mm melamine faced and edged chipboard carcass
- 180x15mm moisture resistant plywood plinth, coloured to match doors and clipped to PVC feet as per Code of Practice
- PVC adjustable feet and clips
- Floor finish to continue to front edge of PVC feet

- 100x50mm sw horizontal anchor rail plugged and screwed to wall G20/210
- 44x25mm sw horizontal rail screwed to anchor rail G20/210
- 50x15mm melamine faced and edged chipboard horizontal rail
- Carousel shelving and post
- 15mm melamine faced and edged chipboard carcass
- Door without handle to extend past door with handle
- 1no. metal 'D' type handle fixed to one door of corner unit only
- 50x15mm melamine faced and edged chipboard horizontal rail
- 2no. 18mm MDF vinyl wrapped profiled doors 570x296mm

**REFERENCES:**

1. FOR SCHEDULE OF SYMBOLS SEE S(07.10)01
2. NIHE CODE OF PRACTICE N11 KITCHEN FURNITURE AND INSTALLATION
3. SEE SPECIFICATION CLAUSE REFERENCES: N11/163
4. TENANTS' OCCUPATIONAL THERAPIST TO BE INVOLVED IN KITCHEN DESIGN. DETAILS ARE GUIDANCE ONLY.

© NIHE 2017 DRAWINGS NOT TO BE SCALED DUE TO PRINTING DISTORTION



TITLE	DRAWN BY	SCALE	DATE
FIXTURES AND FITTINGS (UNIVERSAL USE RANGE)	P&S	1:10	Sept 00
9 uCBU	DRAWING NO.	C(07.10)07	
KITCHEN CORNER BASE UNIT	REV NO. & DATE	(6) 06/16	
	REV NOTE:	15mm thk. horizontal front rail	



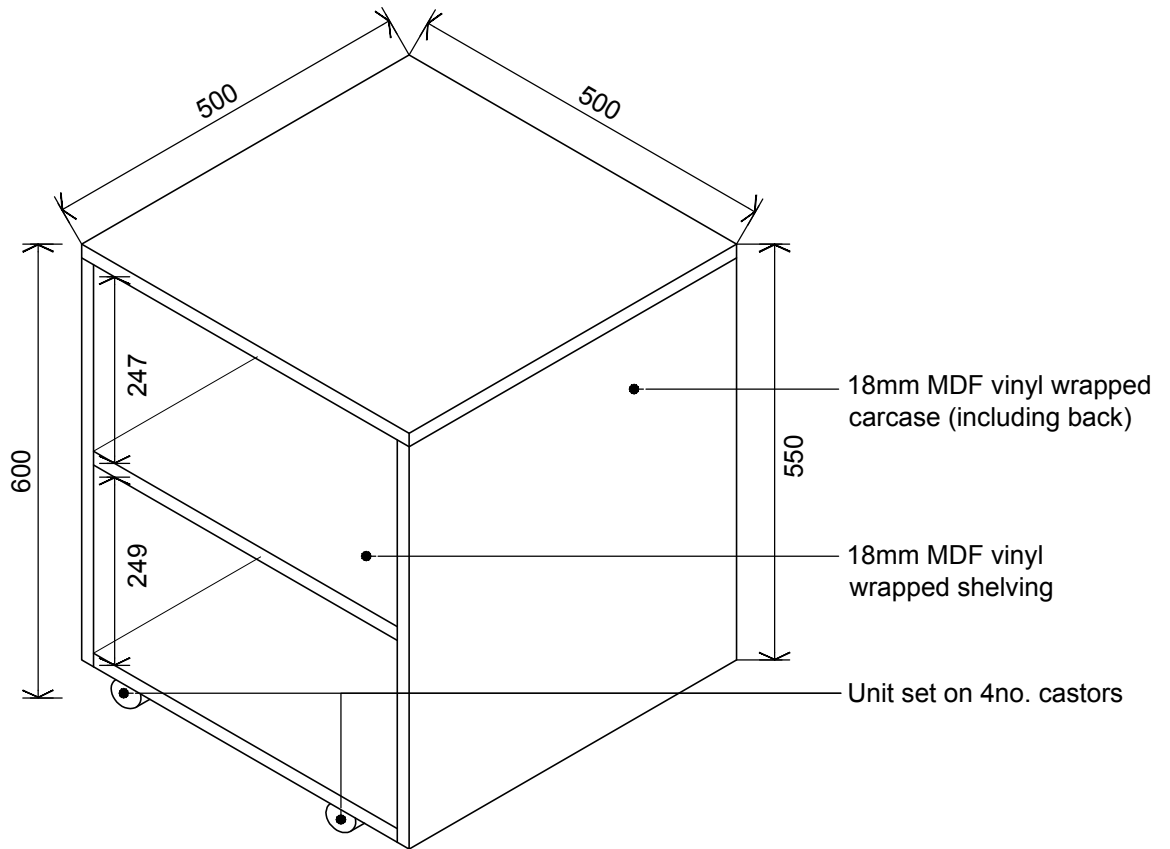

UNIVERSAL USE SINGLE PORTABLE UNIT: 5 uSPU

REFERENCES:

1. FOR SCHEDULE OF SYMBOLS SEE S(07.10)01
2. NIHE CODE OF PRACTICE N11 KITCHEN FURNITURE AND INSTALLATION
3. SEE SPECIFICATION CLAUSE N11/183
4. TENANTS' OCCUPATIONAL THERAPIST TO BE INVOLVED IN KITCHEN DESIGN. DETAILS ARE GUIDANCE ONLY.

© NIHE 2017  
DRAWINGS NOT TO BE SCALED DUE TO PRINTING DISTORTION



TITLE <b>FIXTURES AND FITTINGS</b> (UNIVERSAL USE RANGE)  <b>PORTABLE UNIT DETAIL</b> 5 uSPU	DRAWN BY <b>TJB/CB</b>	SCALE <b>1:10</b>	DATE <b>Sept 00</b>
	DRAWING NO. <b>C(07.10)08</b>		
	REV NO. & DATE <b>(3) 08/12</b>		
	REV NOTE: <b>Updated to revised CoP</b>		





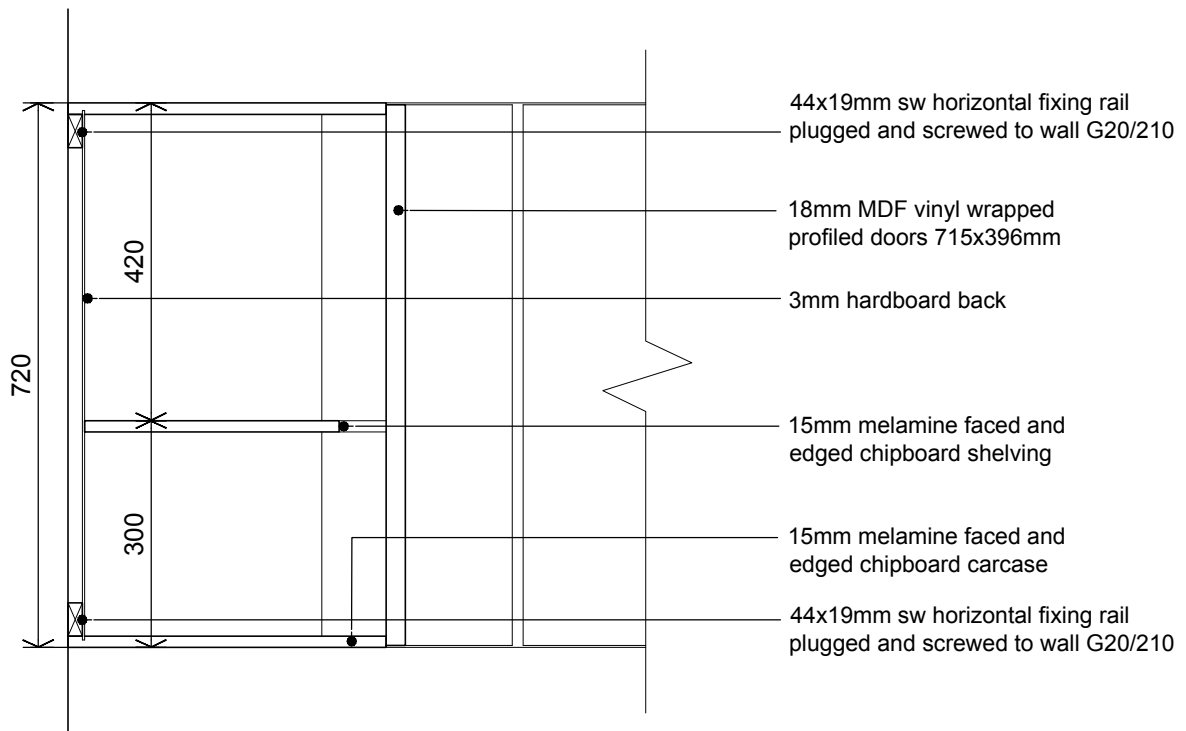

SECTION A:A: 6 CWU (corner wall unit)

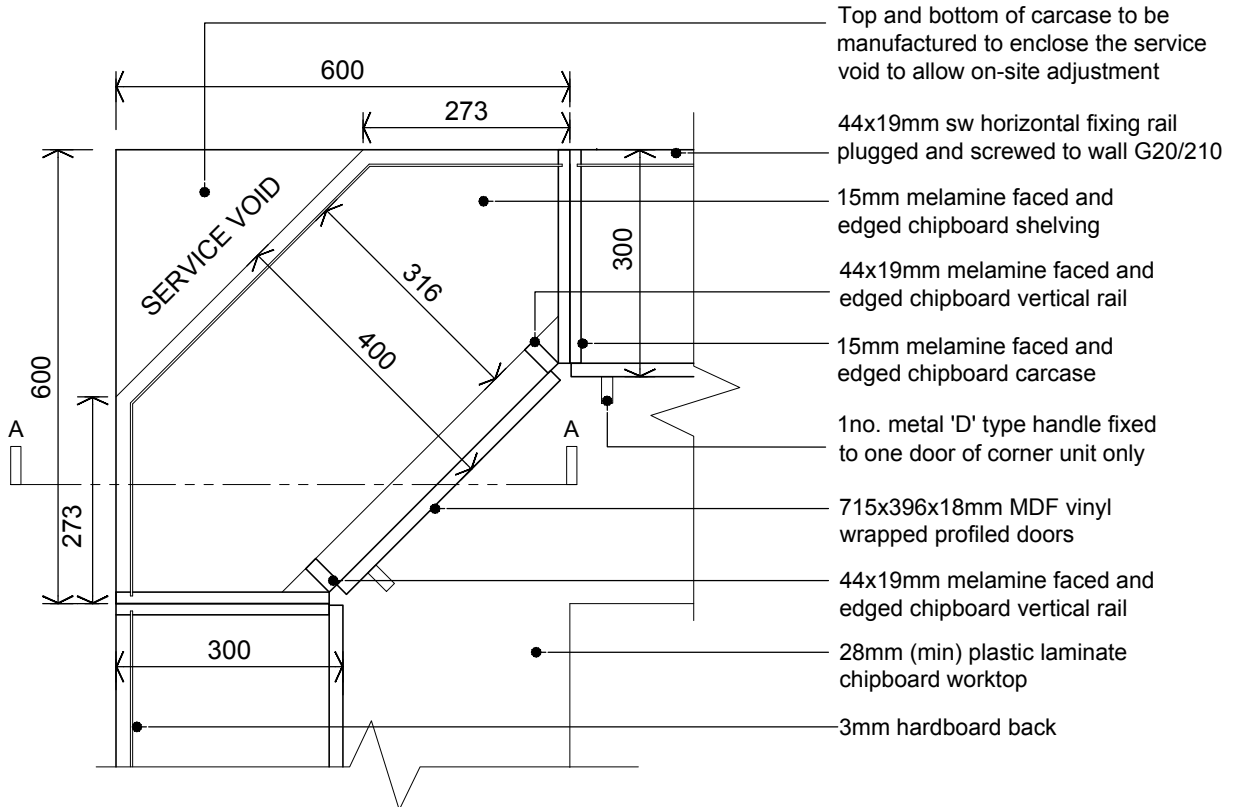

PLAN: 6 CWU (corner wall unit)

REFERENCES:

1. FOR SCHEDULE OF SYMBOLS SEE S(07.10)01
2. NIHE CODE OF PRACTICE N11 KITCHEN FURNITURE AND INSTALLATION
3. SEE SPECIFICATION CLAUSE: N11/153











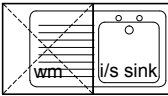

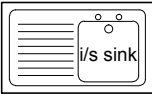
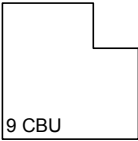

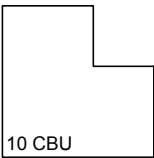

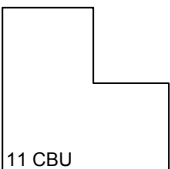
© NIHE 2017 DRAWINGS NOT TO BE SCALED DUE TO PRINTING DISTORTION

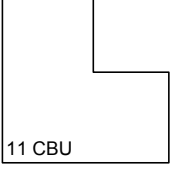

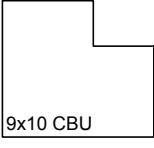
TITLE  
**FIXTURES AND FITTINGS**  
 STANDARD RANGE KITCHEN  
 6 CWU CORNER WALL UNIT  
 TYPICAL PLAN & SECTION

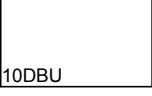
DRAWN BY <b>CB</b>	SCALE <b>1:10</b>	DATE <b>July 12</b>
DRAWING NO. <b>C(07.10)09</b>		
REV NO. & DATE <b>(1) 10/14</b>		
REV NOTE: <b>Shelf height amended</b>		

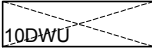

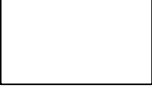
1.		5 SB/SU (Sink unit)	14.		6 CWU (Corner wall unit)
2.		10 DB/SU (Sink unit)	15.		9 CBU (Corner base unit)
3.		Washing Machine (Free standing or under W/T type)	16.		10 CBU (Corner base unit)
4.		600 W Cooker	17.		11 CBU (Corner base unit)
5.		600 W Refrigerator	18.		9x10 CBU (Corner base unit)
6.		3, 4, 5 & 6 SBU (Single base unit)	19.		10x11 CBU (Corner base unit)
7.		5 SB/DU (Drawer unit)	20.		6 EFR (Easy future removed)
8.		8, 10 & 12 DBU (Double base unit)			
9.		3, 4, 5 & 6 SWU (Single wall unit)			
10.		8 & 10 DWU (Double wall unit)			
11.		6 CHU (above cooker hood unit)			
12.		5 STU (2150 high tall unit)			
13.		Worktop (Any length, inc. returns)			



TITLE  
SCHEDULE OF  
SYMBOLS FOR  
STANDARD  
KITCHEN FITTINGS

DRAWN BY TJB/CB	SCALE 1:50	DATE Feb 91
DRAWING NO.	S(07.10)01	
REV NO. & DATE	(1) 09/12	
REV NOTE: Updated to revised CoP		



\* This NIHE produced detail has been examined by The Building Control N.I. Standards Panel and has been considered reasonable in its interpretation of the relevant requirements of the Building Regulation NI 2012. There is no legal obligation for any Building Control department to adopt this recommendation & it is subject to revision in the event of changes to the legislation or other mitigating circumstances.

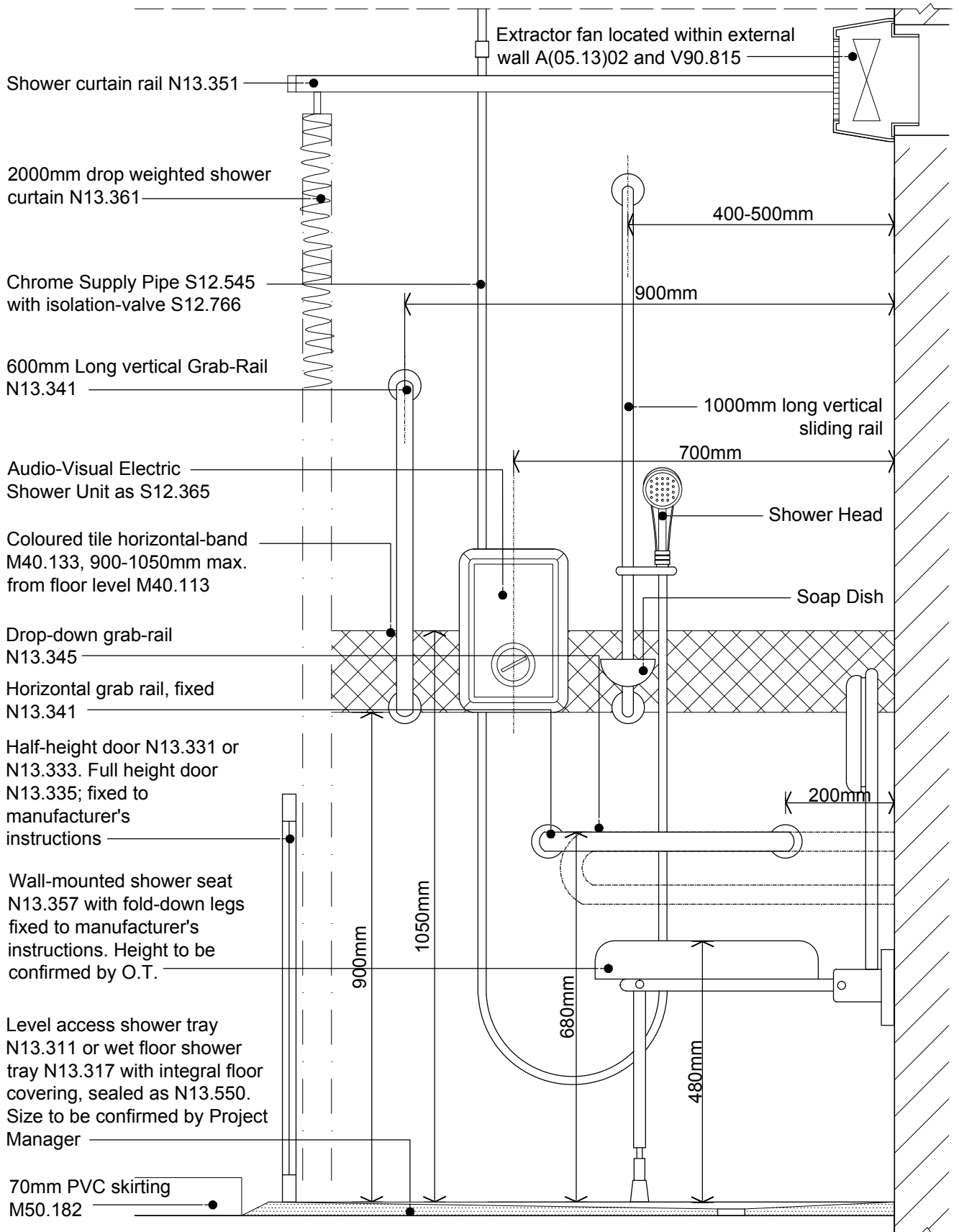

NOTE: - Ceiling mounted enclosed bathroom light fitting V90.691  
 - Dimensions highlighted are for guidance only and are subject to O.T.'s recommendations

**Housing Executive**

*BCNI Standards Panel Agreed \**

TITLE

**SHOWER ENCLOSURE ELEVATION LAYOUT & GUIDANCE**

DRAWN BY <b>P&amp;S</b>	SCALE <b>1:10</b>	DATE <b>May 08</b>
DRAWING NO.	<b>A(07.12)01</b>	
REV NO. & DATE	<b>2 (07/16)</b>	
REV NOTE: <b>Updated to Building Regs</b>		

© NIHE 2017  
 DRAWINGS NOT TO BE SCALED DUE TO PRINTING DISTORTION

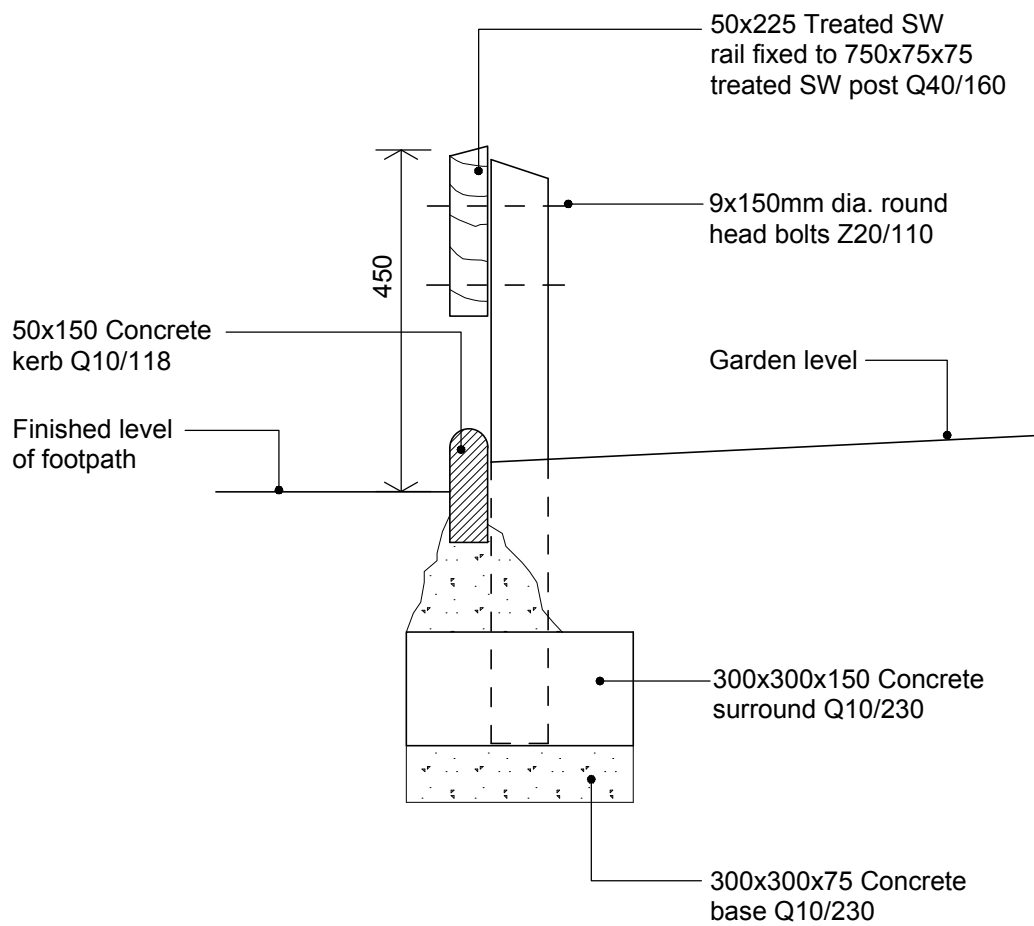

SECTION



TITLE <b>LOW LEVEL FRONT GARDEN RAIL</b>	DRAWN BY <b>TJB</b>	SCALE <b>1:10</b>	DATE <b>Apr 91</b>
	DRAWING NO. <b>A(08.10)01</b>		
	REV NO. & DATE <b>(3) 9/99</b>		
	REV NOTE:		



44x69mm splayed treated SW horizontal runner (top and bottom)

PC concrete posts 100 x 100mm

20x144 treated SW vertical boards @ 165mm centres

50x150 Concrete kerb Q10.118

ELEVATION

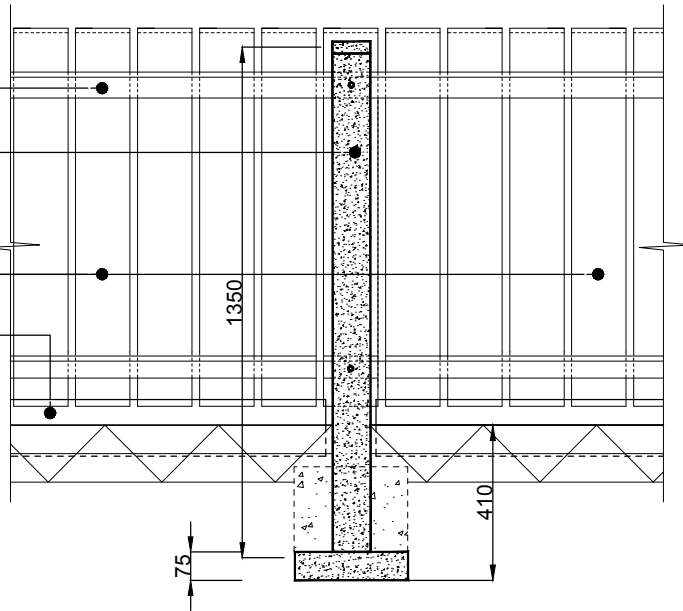

20 x144 treated SW vertical boards @ 165mm centres

44x69 splayed treated SW runners Q40.130

100x100 precast conc. post

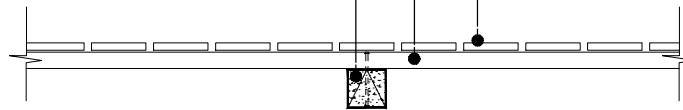

PLAN

44x69 Splayed treated SW runners Q40.130 (top and bottom)

20x144 treated sw vertical boards splayed top and bottom Q40.130

Concrete posts 100 x 100mm

50x150 Concrete kerb Q10.118

300x300 Concrete around posts

75mm Concrete base

SECTION

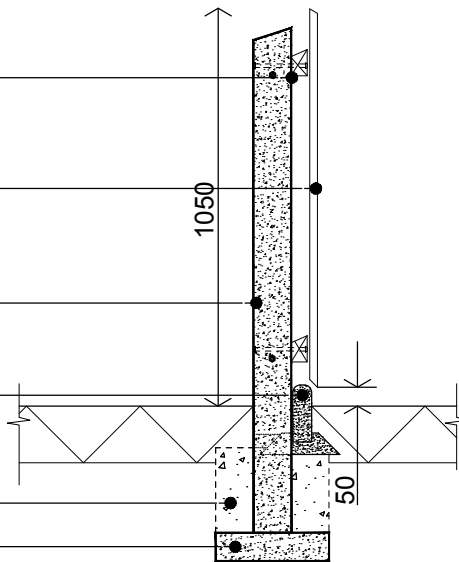

**UNPROTECTED AND / OR EXPOSED FENCING LOCATIONS**  
Bullwire to be stapled over vertical boarding at ledging and bracing locations, Q40.133 to employers' discretion

© NIHE 2017 DRAWINGS NOT TO BE SCALED DUE TO PRINTING DISTORTION



TITLE  
**TIMBER FENCING AND GATE AT 1050 HIGH**

DRAWN BY <b>P&amp;S</b>	SCALE <b>1:20</b>	DATE <b>Apr 91</b>
DRAWING NO.	<b>A(08.10)02</b>	
REV NO. & DATE	<b>(3) 12/16</b>	
REV NOTE: Updated to revised spec		



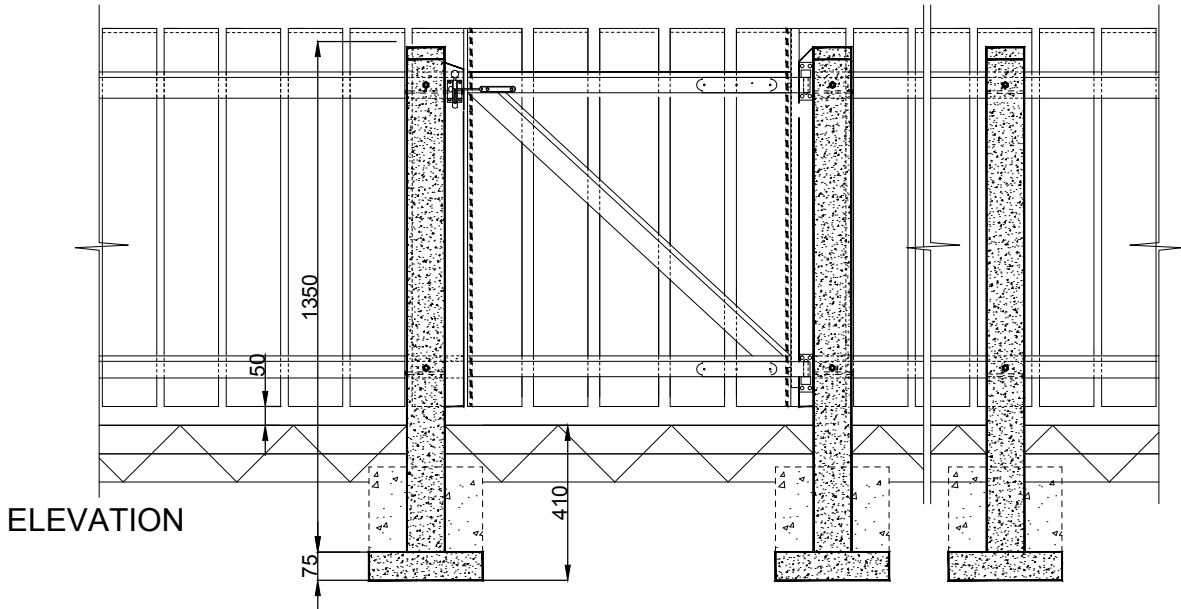

ELEVATION

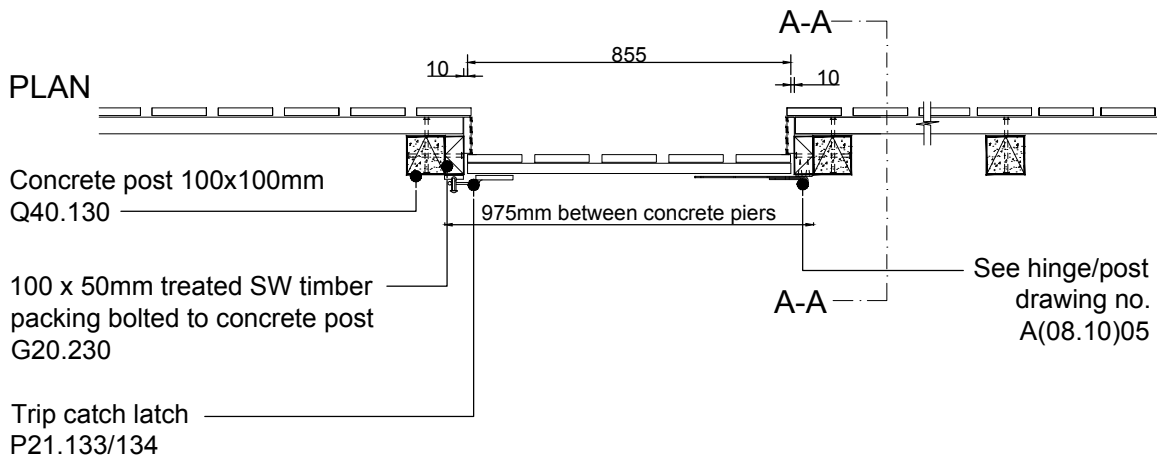

PLAN

Concrete post 100x100mm  
Q40.130

100 x 50mm treated SW timber  
packing bolted to concrete post  
G20.230

Trip catch latch  
P21.133/134

A-A

A-A

See hinge/post  
drawing no.  
A(08.10)05

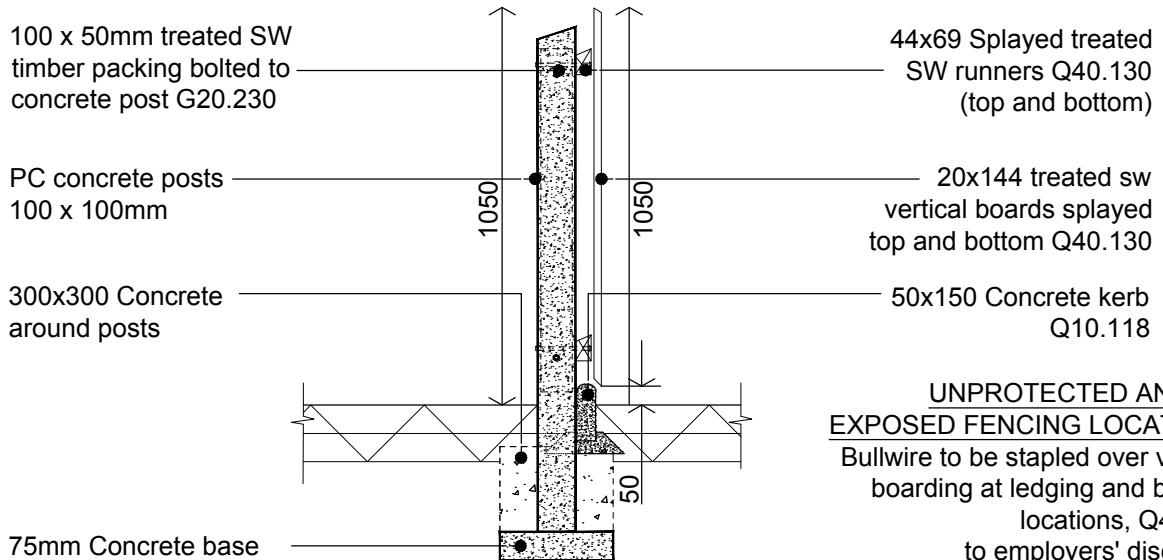

100 x 50mm treated SW  
timber packing bolted to  
concrete post G20.230

PC concrete posts  
100 x 100mm

300x300 Concrete  
around posts

75mm Concrete base

44x69 Splayed treated  
SW runners Q40.130  
(top and bottom)

20x144 treated sw  
vertical boards splayed  
top and bottom Q40.130

50x150 Concrete kerb  
Q10.118

**UNPROTECTED AND/OR  
EXPOSED FENCING LOCATIONS**

Bullwire to be stapled over vertical  
boarding at ledging and bracing  
locations, Q40.133  
to employers' discretion

SECTION

© NIHE 2017  
DRAWINGS NOT TO BE SCALED DUE TO PRINTING DISTORTION



TITLE

TIMBER FENCING  
AND GATE  
1050 HIGH

DRAWN BY  
P&S

SCALE  
1:20

DATE  
Apr 91

DRAWING NO.

A(08.10)03

REV NO. & DATE

(3) 12/16

REV NOTE:

Updated to revised spec



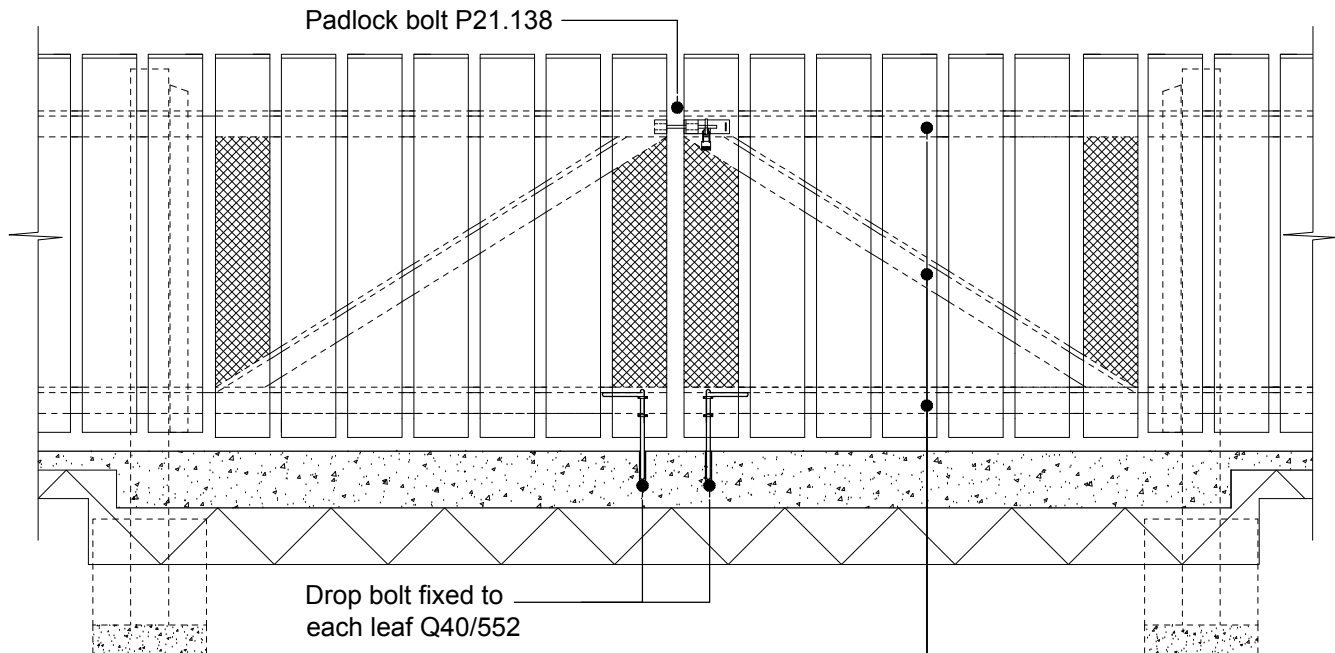

ELEVATION

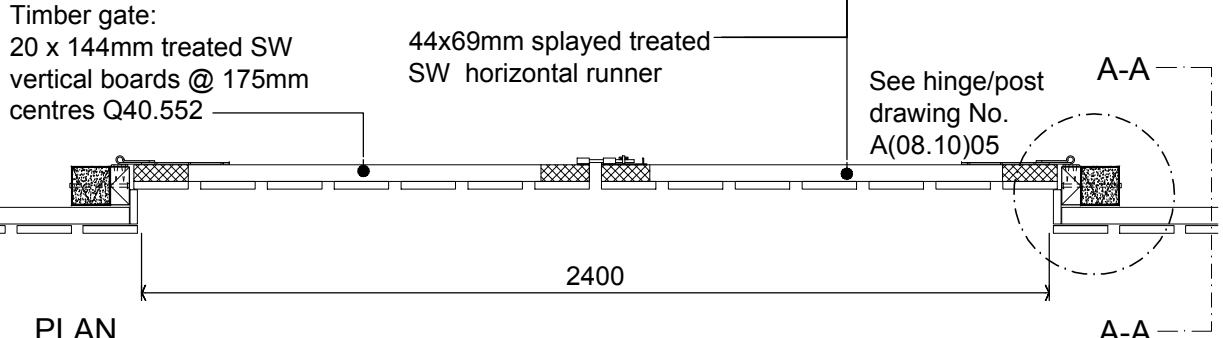

PLAN

- 44x69 Splayed treated SW runners Q40.130 (top and bottom)
- 20x144 treated SW vertical boards splayed top and bottom Q40.130
- 50x150 Concrete kerb Q10.118
- UNPROTECTED AND/OR EXPOSED FENCING LOCATIONS**  
Bullwire to be stapled over vertical boarding at ledging and bracing locations, Q40.133 to employers' discretion

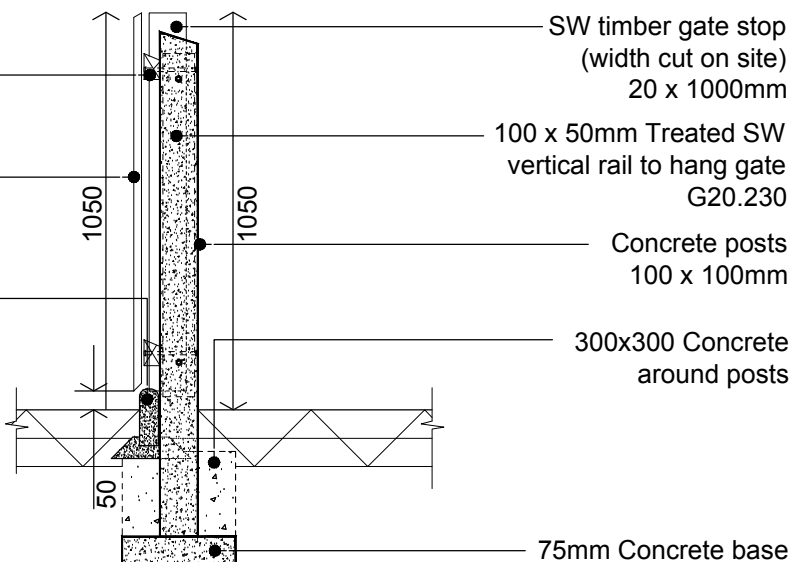

SECTION

© NIHE 2017 DRAWINGS NOT TO BE SCALED DUE TO PRINTING DISTORTION



TITLE	TIMBER GATES (DOUBLE) IN TIMBER FRAME		
-------	---------------------------------------	--	--

DRAWN BY	SCALE	DATE
P&S	1:20	Apr 91
DRAWING NO.	A(08.10)04	
REV NO. & DATE	(4) 12/16	
REV NOTE:	Construction change	



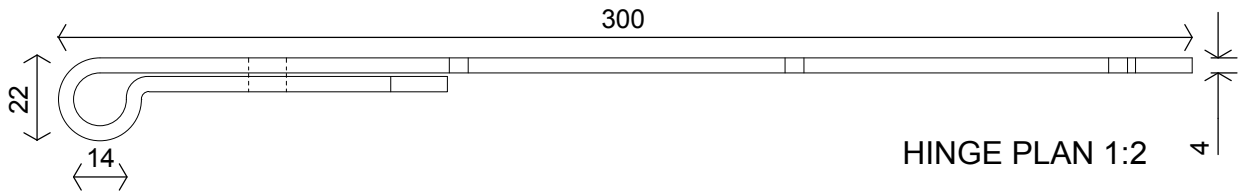

HINGE PLAN 1:2

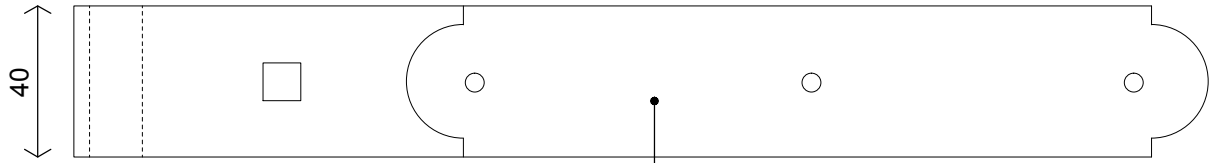

HINGE ELEVATION 1:2

Hinge to be formed from galvanised mild steel strap as shown Q40/550

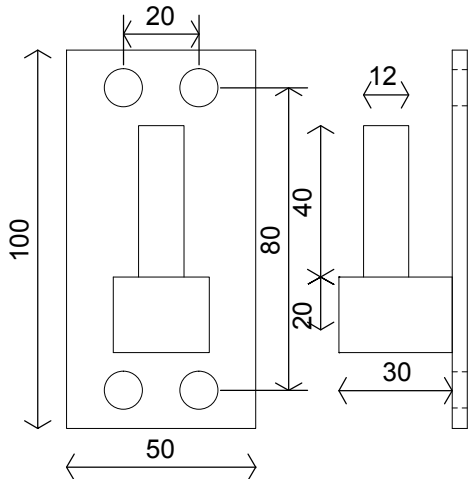

ELEVATIONS 1:2

**BRACKET**

- top bracket faces upwards and the bottom one downwards - brackets to be formed of solid galvanised mild steel to form hook welded to bracket Q40/550

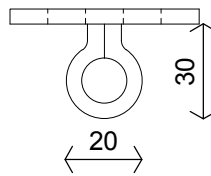

PLAN 1:2

AXONOMETRIC VIEW OF ASSEMBLY 1:10

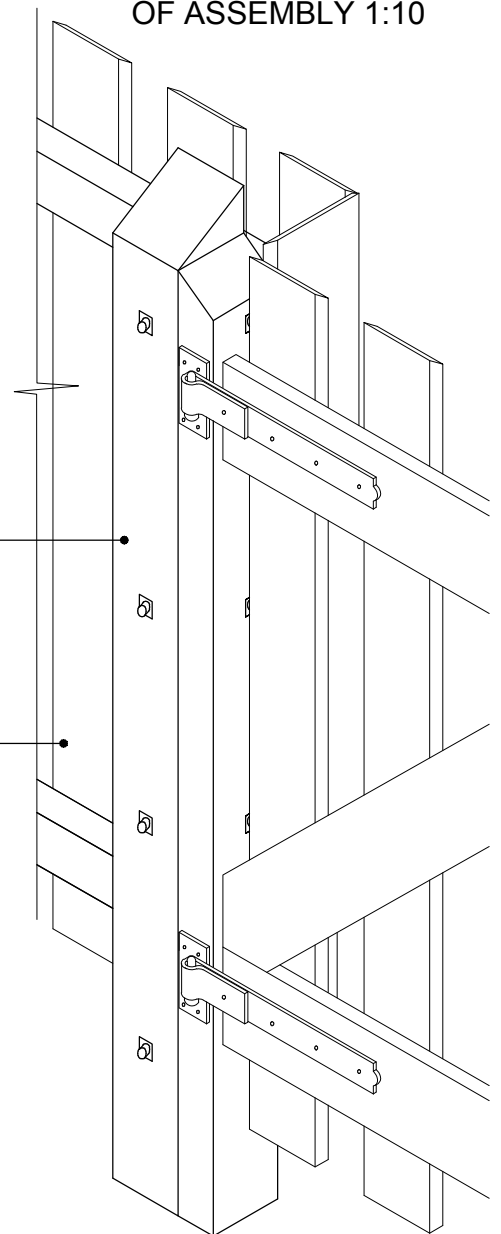

PC concrete posts

20x144 treated SW vertical boards splayed top and bottom Q40.130

50x100 treated SW vertical rail to take hinge, bolted to P.C. post G20/230, Q40/130

Galvanised MS hinge to sit onto brackets as shown Q40.550

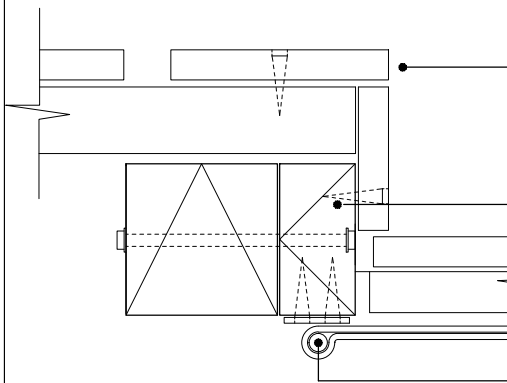

PLAN OF ASSEMBLY 1:5

All screws to be 38mm No.12 non-ferrous MS screws Q40.550

© NIHE 2017 DRAWINGS NOT TO BE SCALED DUE TO PRINTING DISTORTION



<b>TITLE</b>  HINGE/POST DETAIL	DRAWN BY <b>P&amp;S</b>	SCALE 1:2,1:5,1:10	DATE Apr 91
	DRAWING NO. A(08.10)05		
	REV NO. & DATE (2) 12/16		
	REV NOTE: Gate connection detail amended		





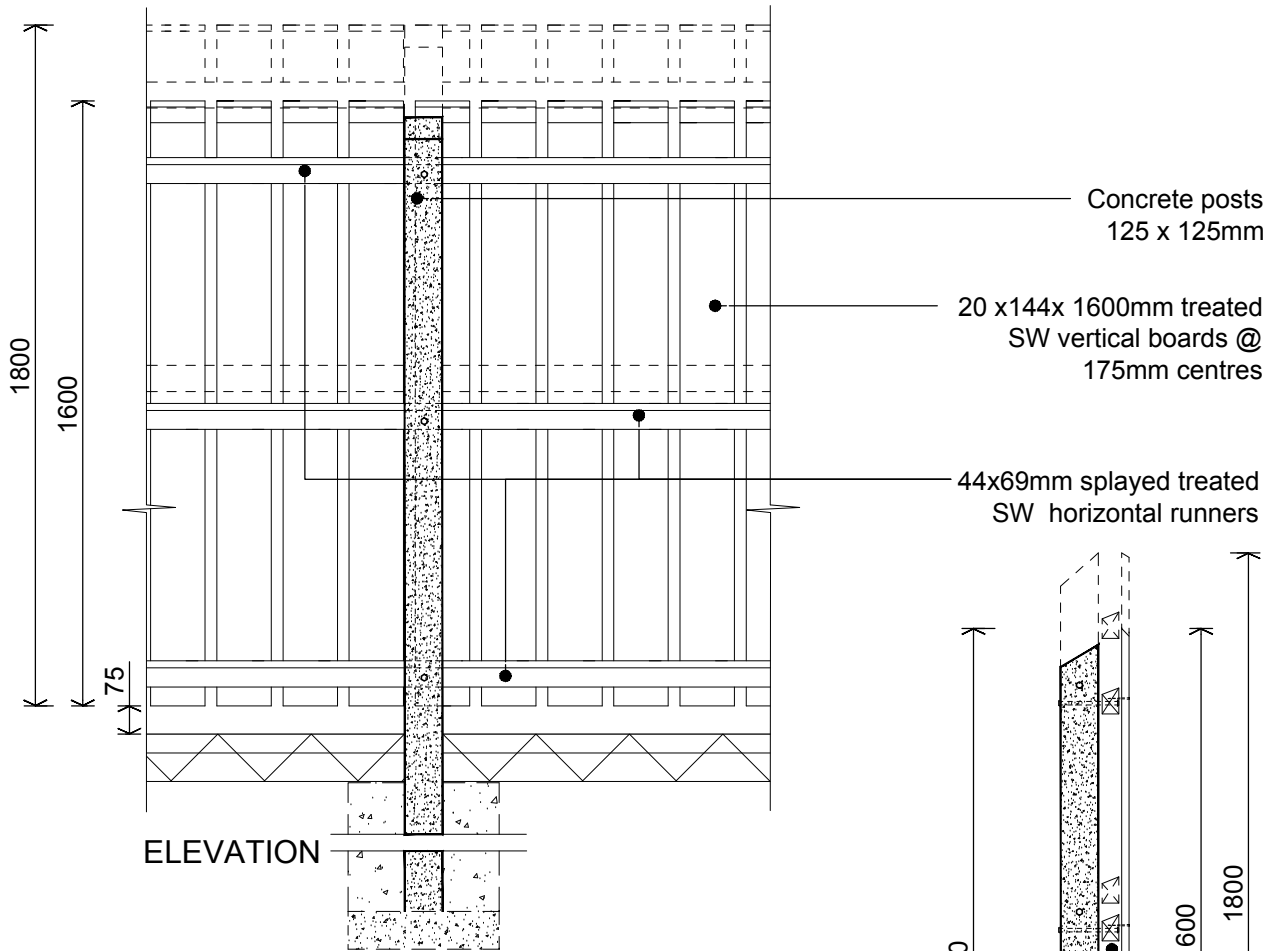

ELEVATION

Concrete posts  
125 x 125mm

20 x 144 x 1600mm treated  
SW vertical boards @  
175mm centres

44x69mm splayed treated  
SW horizontal runners

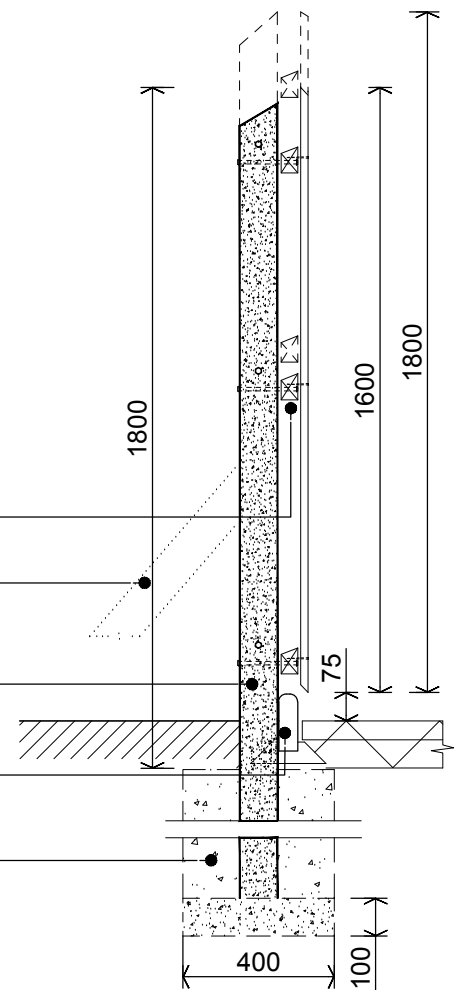

SECTION

44x69 Splayed treated SW runners

Precast concrete stays to be  
used on corners Q40.136/146

125 x 125mm precast concrete post

50x150 Concrete kerb  
Q10/120

400 x 400 x 600 mm concrete around posts

UNPROTECTED AND / OR EXPOSED FENCING LOCATIONS:

Bullwire to be stapled over vertical boarding at ledging and  
bracing locations at employers' discretion.

Q40.138 (1675 mm high fence)

Q40.152 (1875 mm high fence)

Specification References:

Q40.135 & Q40.551 for 1675mm high fence & gate

Q40.150 & Q40.553 for 1875mm high fence & gate

1875 mm high fence shown as short dashed line

© NIHE 2017  
DRAWINGS NOT TO BE SCALED DUE TO PRINTING DISTORTION



TITLE	DRAWN BY		SCALE	DATE
<b>TIMBER FENCING</b> 1675 & 1875 mm high	P&S		1:20	Apr 91
	DRAWING NO.		A(08.10)06	
	REV NO. & DATE		(5) 12/16	
	REV NOTE: Updated for revised spec			

DRAWN BY		SCALE	DATE
P&S		1:20	Apr 91
DRAWING NO.		A(08.10)06	
REV NO. & DATE		(5) 12/16	
REV NOTE: Updated for revised spec			



Specification References:

Q40.135 & Q40.551 for 1675mm high fence & gate

Q40.150 & Q40.553 for 1875mm high fence & gate

1875 mm high fence shown as short dashed line

44x69mm splayed treated SW horizontal runner

20 x144 treated SW vertical boards @ 175mm centres

44 x 69mm splayed treated SW bracing

Padlock bolt P21.138

Timber gate:

5no. 20 x 144mm treated SW vertical boards

44 x 69mm splayed treated SW bracing

Bracket hinges

See A(08.10)05

50x125mm treated SW rail G20.230

Concrete posts 125 x 125mm

20x144 treated SW vertical boards @ 175mm centres

50x125 treated SW packing bolted to 125x125 P.C. post G20.230

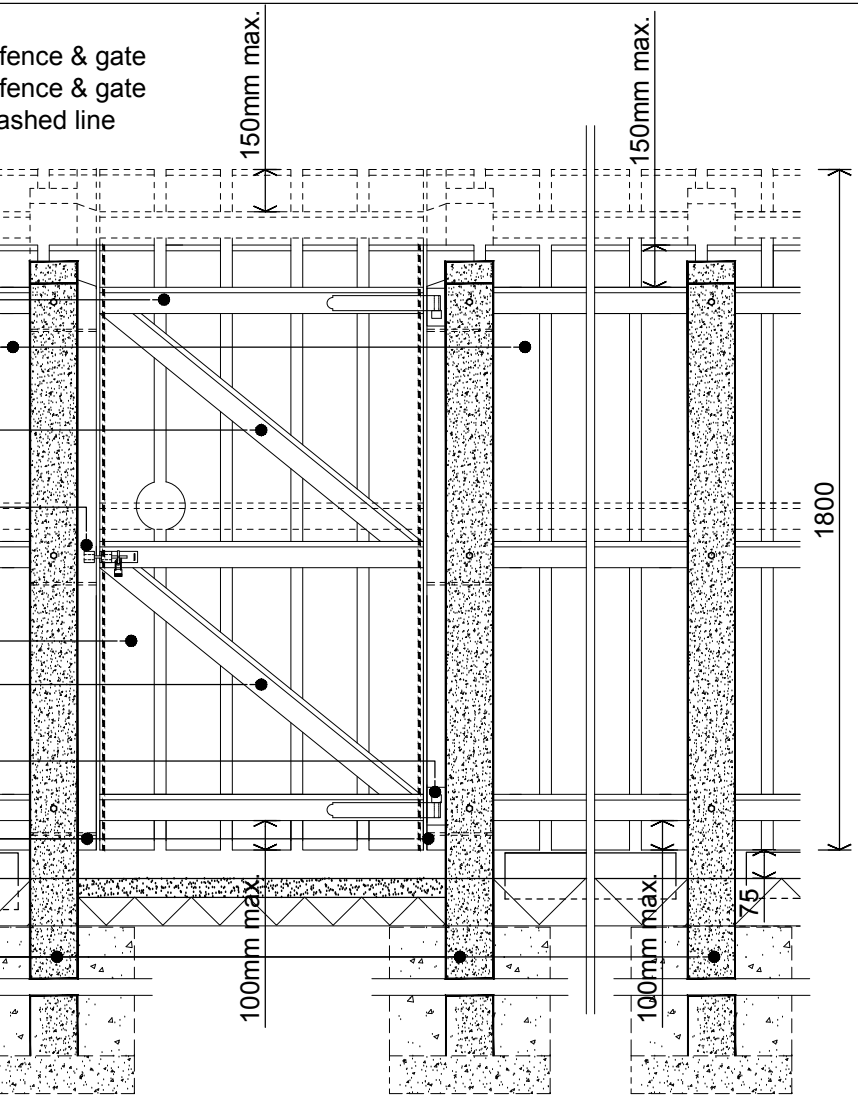

**ELEVATION**

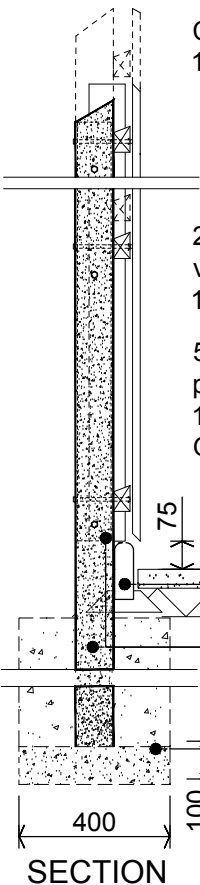

**SECTION**

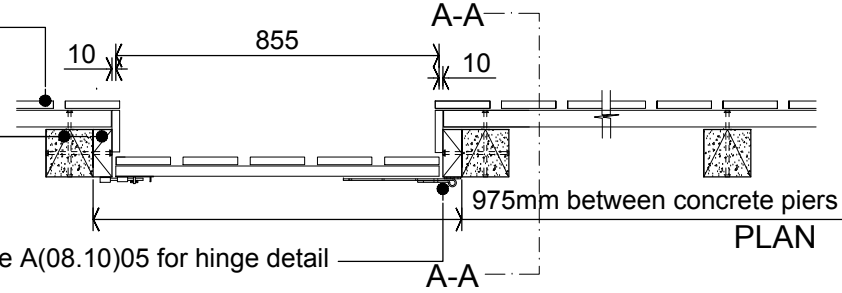

**PLAN**

See A(08.10)05 for hinge detail

50x150 Concrete kerb Q10.118

125 x 125mm PC concrete post and 50 x 125mm treated SW timber

400 x 400 x 600mm concrete around posts

UNPROTECTED AND / OR EXPOSED FENCING LOCATIONS:

Bullwire to be stapled over vertical boarding at ledging and bracing locations at employers' discretion.

© NIHE 2017 DRAWINGS NOT TO BE SCALED DUE TO PRINTING DISTORTION



TITLE	DRAWN BY	SCALE	DATE
TIMBER FENCING WITH GATE 1675 - 1875 mm high	P&S	1:20	Apr 91
	DRAWING NO.	A(08.10)07	
	REV NO. & DATE	(5) 12/16	
	REV NOTE:	Updated to revised spec	

DRAWN BY	SCALE	DATE
P&S	1:20	Apr 91
DRAWING NO.	A(08.10)07	
REV NO. & DATE	(5) 12/16	
REV NOTE:	Updated to revised spec	



Specification References:

Gate: Q40.554

Fence: Q40.145

44x69mm splayed treated SW horizontal runner

Concrete posts  
125 x 125mm

44 x 69mm splayed treated SW bracing

Padlock bolt P21.138

44x69mm splayed treated SW horizontal runner

20 x 144mm treated SW diagonal boards

44 x 69mm splayed treated SW bracing

44x69mm splayed treated SW frame

50x100mm treated SW rail G20.230

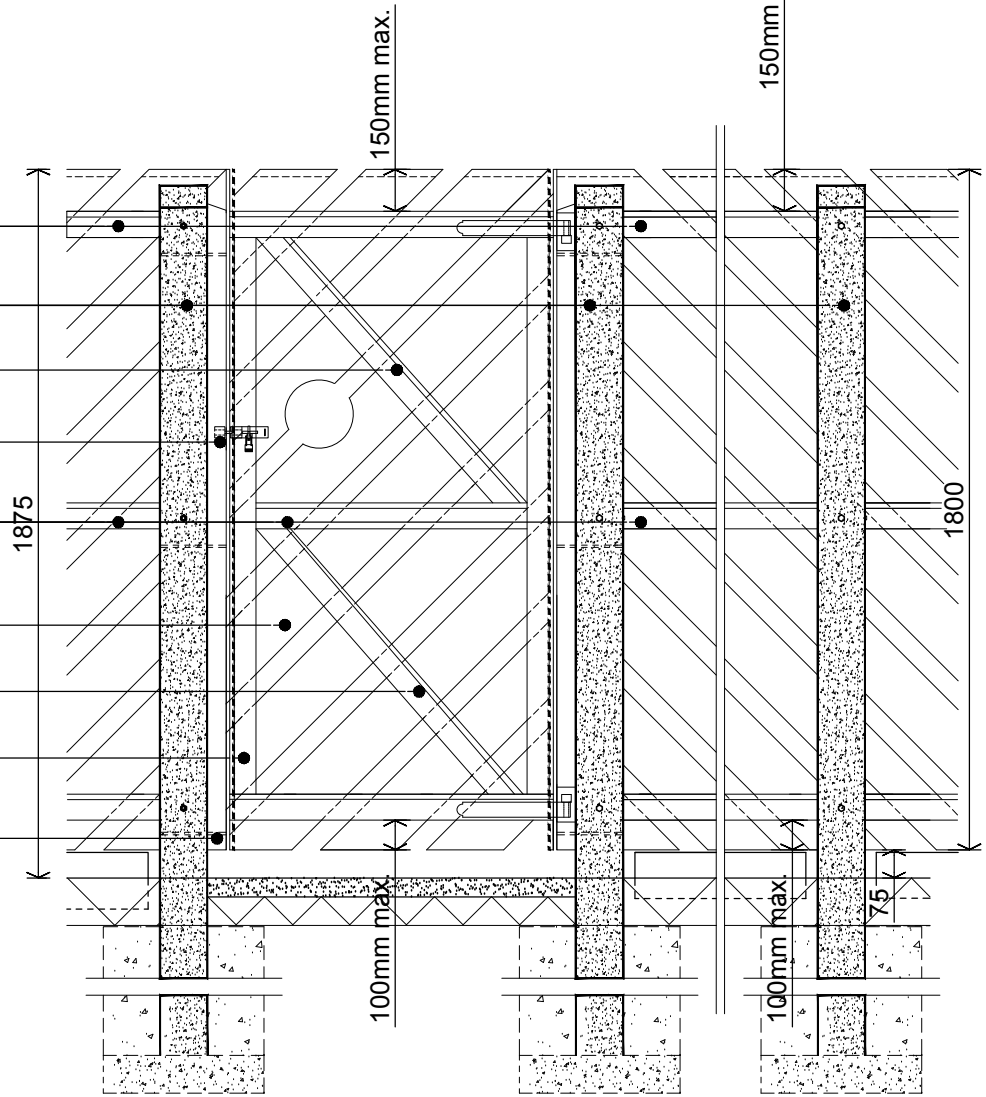

ELEVATION

20x144 treated SW vertical boards @ 175mm centres

50x125 treated SW packing bolted to 125x125 P.C. post G20.230

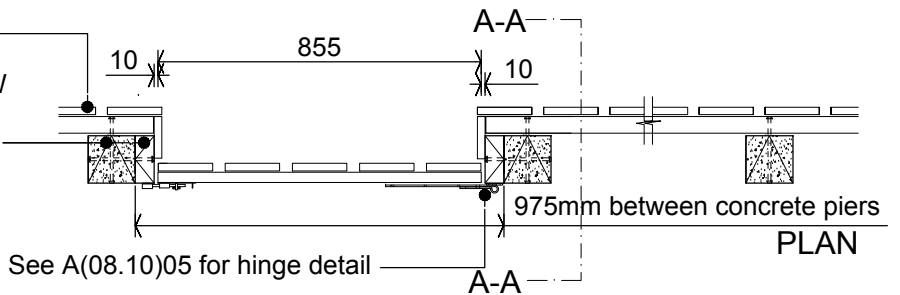

PLAN

See A(08.10)05 for hinge detail

UNPROTECTED AND / OR EXPOSED FENCING LOCATIONS:

Bullwire to be stapled over vertical boarding at ledging and bracing locations at employers' discretion.

© NIHE 2017 DRAWINGS NOT TO BE SCALED DUE TO PRINTING DISTORTION



TITLE	TIMBER GATE (SINGLE) IN DIAGONAL TIMBER FENCE		
-------	---	--	--

DRAWN BY	P&S	SCALE	1:20	DATE	Apr 91
DRAWING NO.	A(08.10)08				
REV NO. & DATE	(4) 12/16				
REV NOTE:	Updated to revised spec				



© NIHE 2017  
DRAWINGS NOT TO BE SCALED DUE TO PRINTING DISTORTION

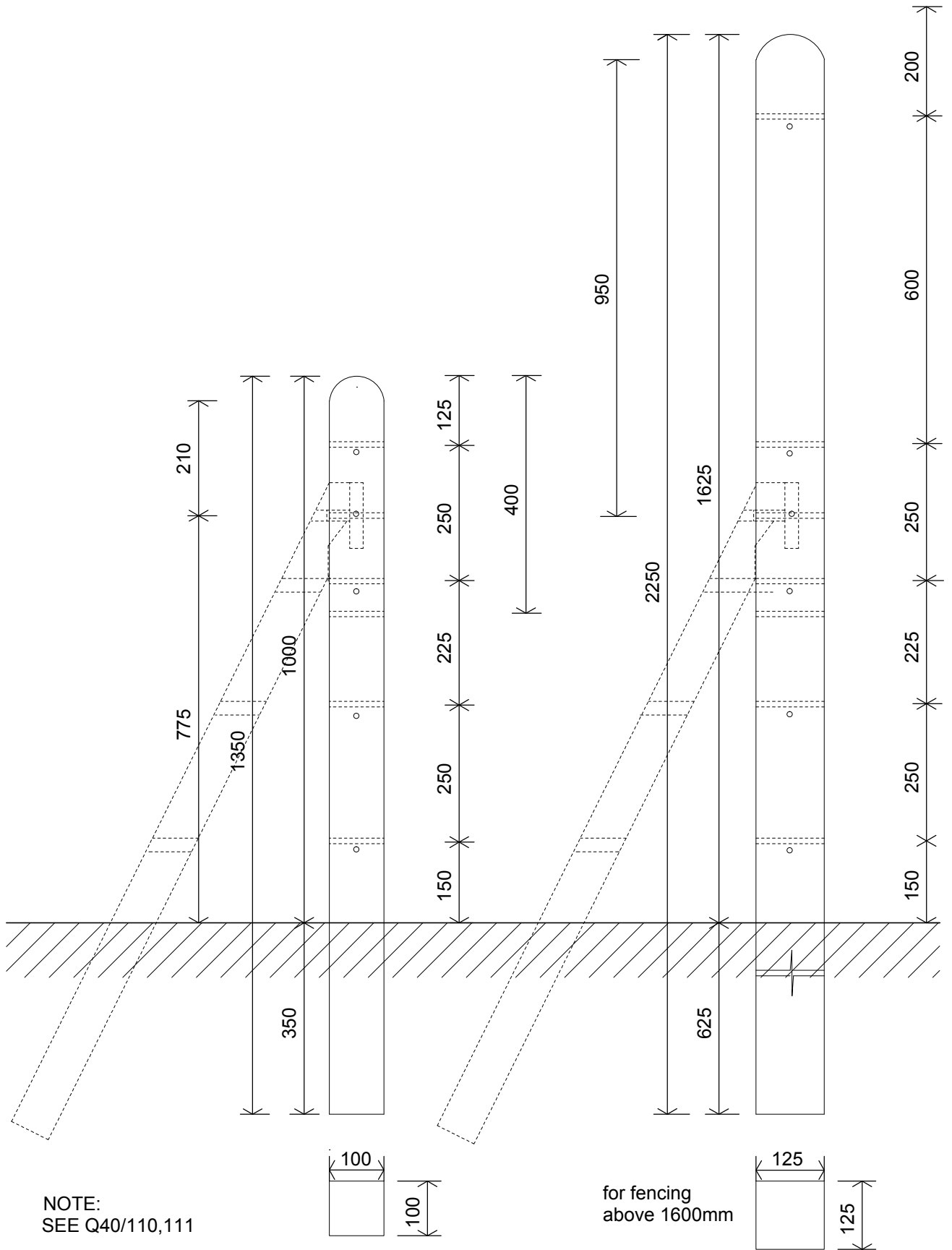

NOTE:  
SEE Q40/110,111

for fencing  
above 1600mm



TITLE  
**CONCRETE CHAINLINK  
POSTS**

DRAWN BY <b>P&amp;S</b>	SCALE <b>1:10</b>	DATE <b>Apr 91</b>
DRAWING NO.	<b>A(08.10)10</b>	
REV NO. & DATE	<b>(2) FEB 2015</b>	
REV NOTE: <b>Updated for revised spec</b>		



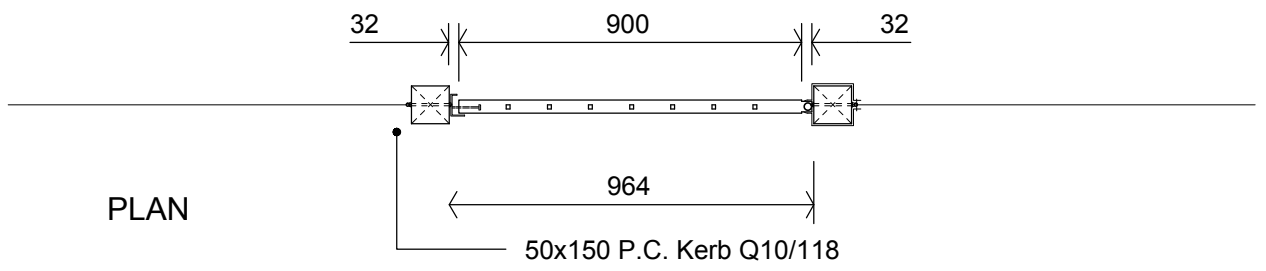
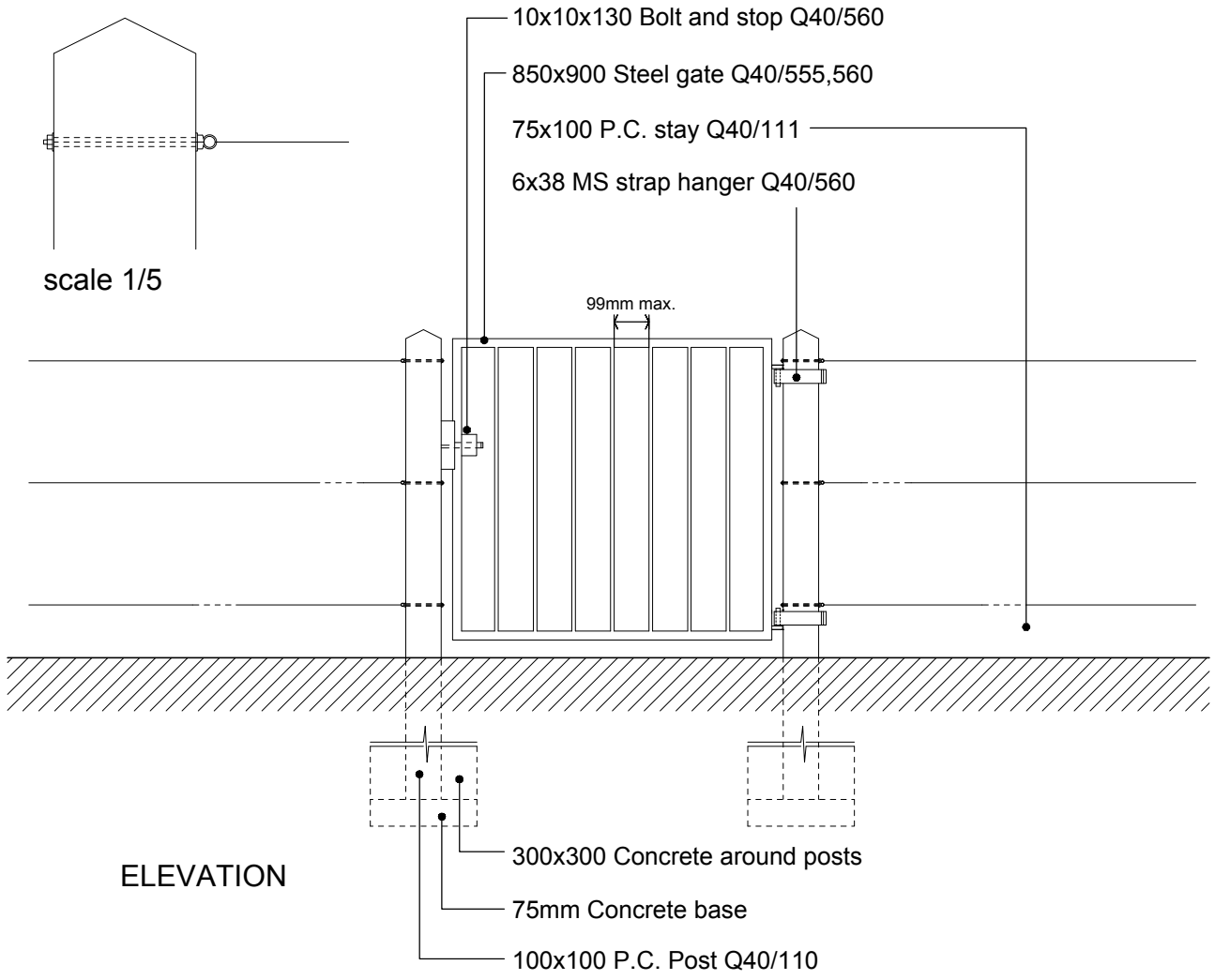
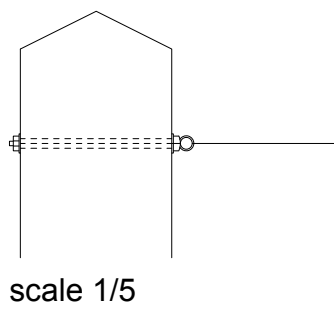

NOTE: Gate to be hung with top and bottom lugs as show to prevent removal.

© NIHE 2017  
DRAWINGS NOT TO BE SCALED DUE TO PRINTING DISTORTION



TITLE	STEEL GATE (SINGLE) WITH POST AND WIRE FENCING		
-------	--	--	--

DRAWN BY P&S	SCALE 1:20	DATE Apr 91
DRAWING NO.	A(08.10)11	
REV NO. & DATE	(2) feb 2015	
REV NOTE: Updated to revised spec		

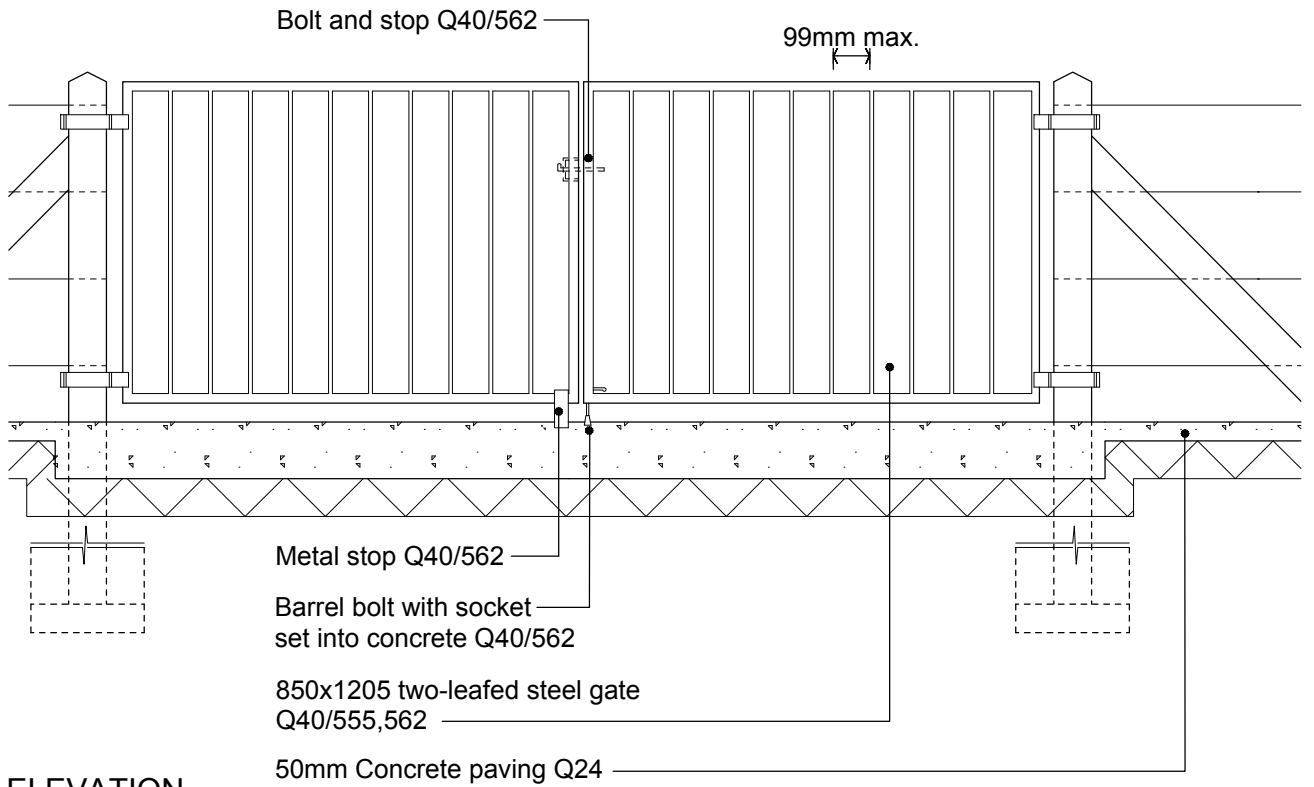

ELEVATION

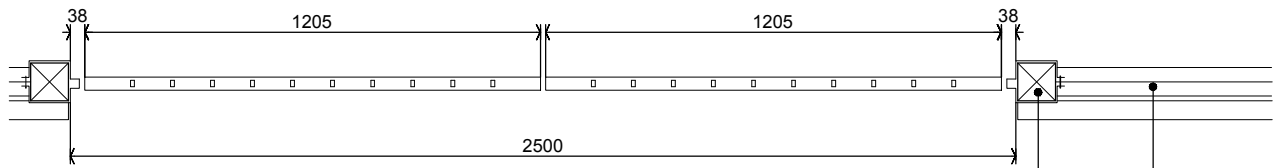

PLAN

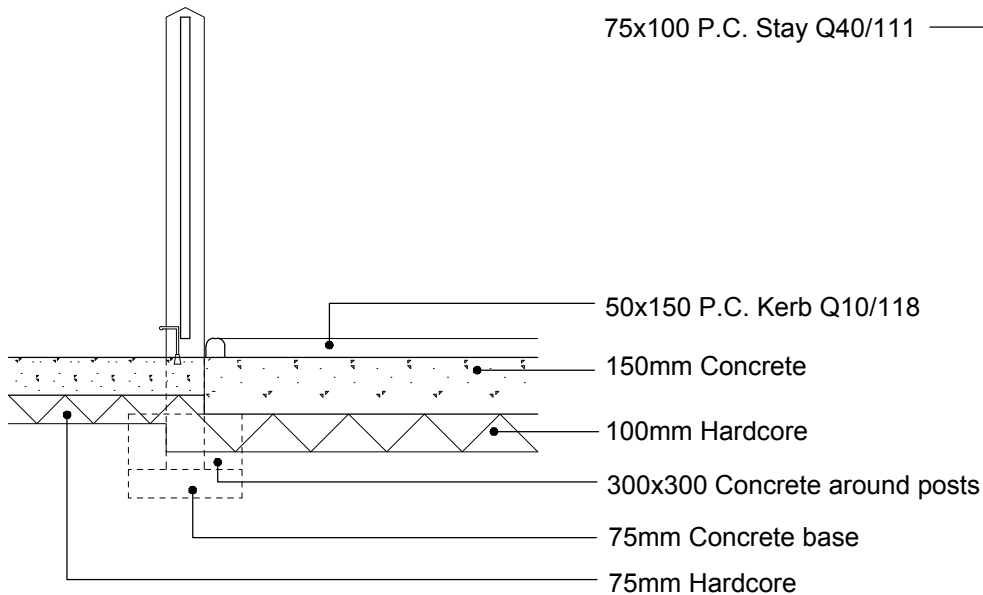

SECTION

© NIHE 2017 DRAWINGS NOT TO BE SCALED DUE TO PRINTING DISTORTION



TITLE <b>STEEL GATE (DOUBLE)          WITH POST AND WIRE          FENCING</b>	DRAWN BY <b>TJB/CB</b>	SCALE <b>1:20</b>	DATE <b>Apr 91</b>
	DRAWING NO. <b>A(08.10)12</b>		
	REV NO. & DATE <b>(3) 09/12</b>		
	REV NOTE: <b>Updated to revised spec</b>		

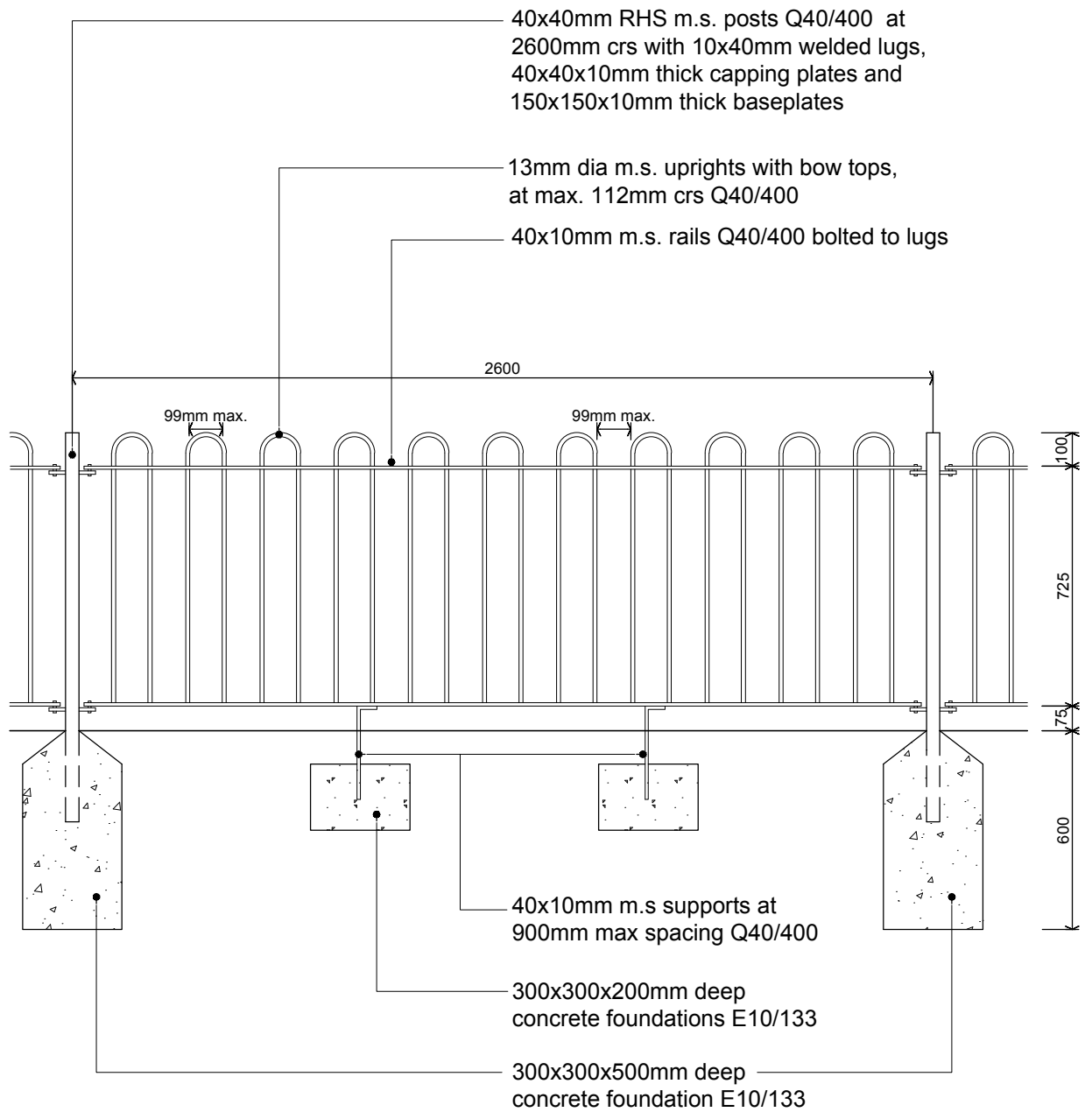

## ELEVATION

All mild steel components to be galvanised (Z11/360) after construction and painted after assembly on site (M60/150)



<b>TITLE</b>  <b>RAILINGS</b> steel bow topped	<b>DRAWN BY</b> P&S	<b>SCALE</b> 1:20	<b>DATE</b> Sept 91
	<b>DRAWING NO.</b>	A(08.10)13	
	<b>REV NO. &amp; DATE</b>	(4) 09/14	
	<b>REV NOTE:</b> Top Rail Lowered		

© NIHE 2017  
 DRAWINGS NOT TO BE SCALED DUE TO PRINTING DISTORTION

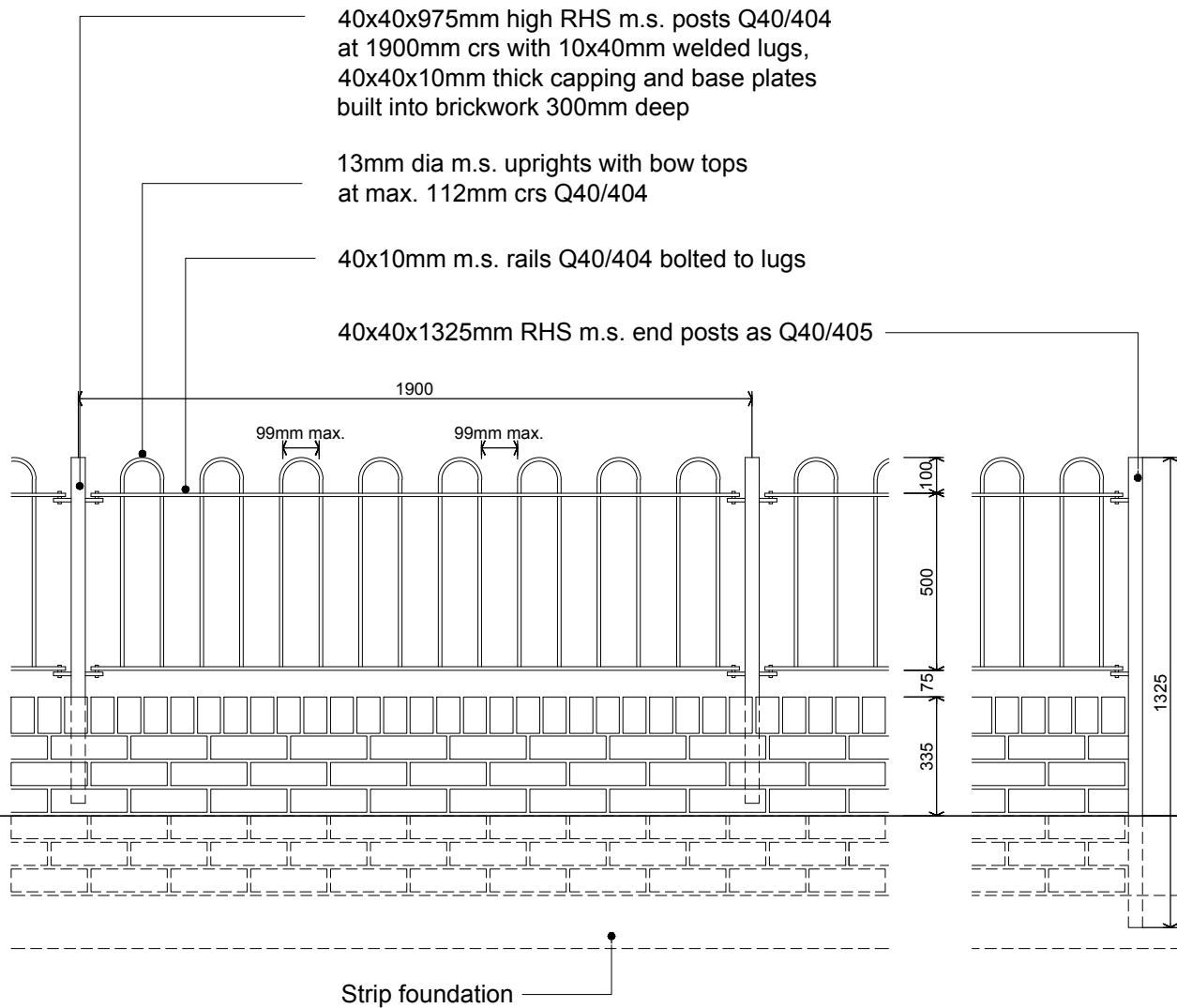

## ELEVATION

All mild steel components to be galvanised (Z11/360) after construction and painted after assembly on site (M60/150)



TITLE

RAILINGS  
steel bow topped  
on dwarf wall

DRAWN BY  
P&S

SCALE  
1:20

DATE  
Jan 98

DRAWING NO.

A(08.10)14

REV NO. & DATE

(3) 09/14

REV NOTE:

Top Rail Lowered





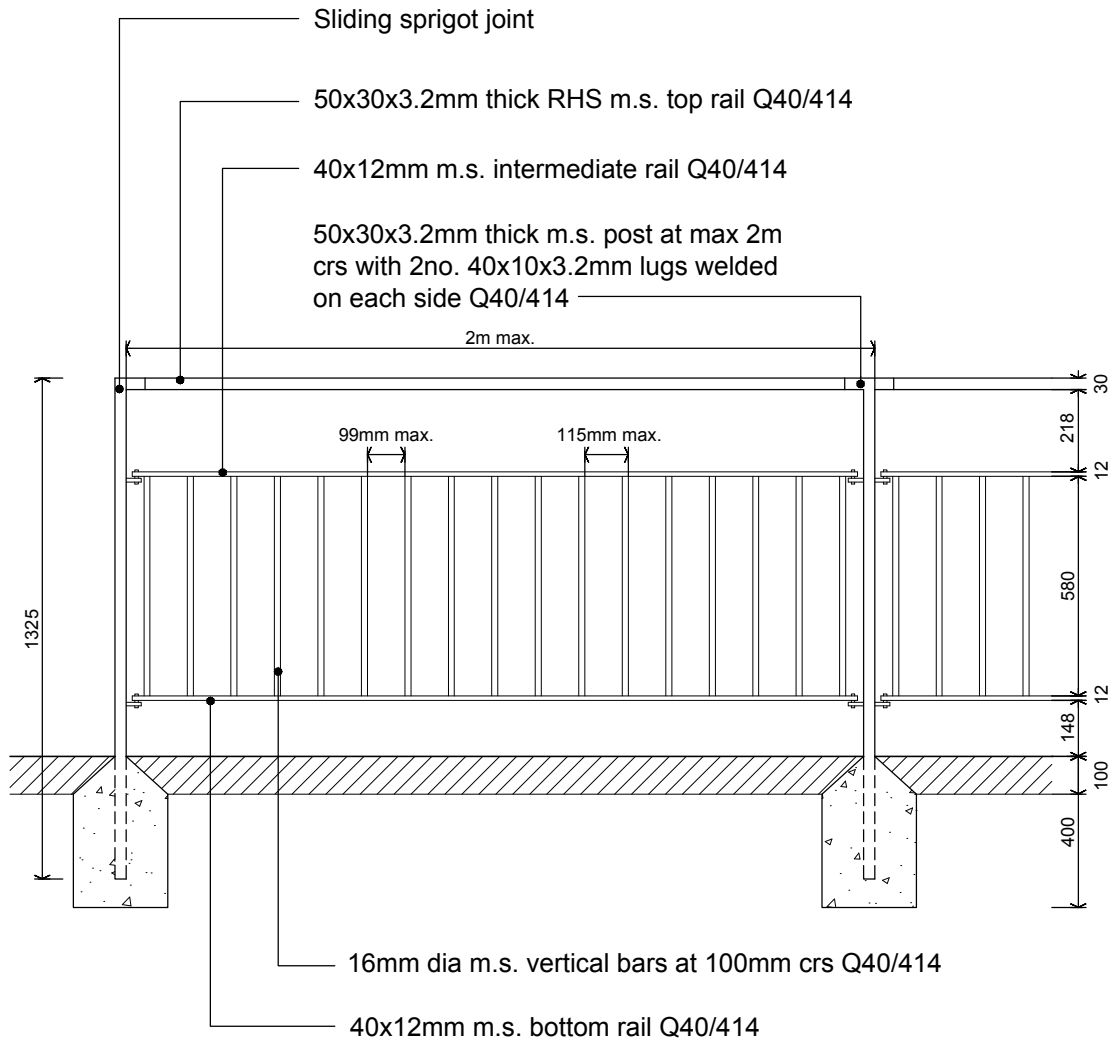

### ELEVATION

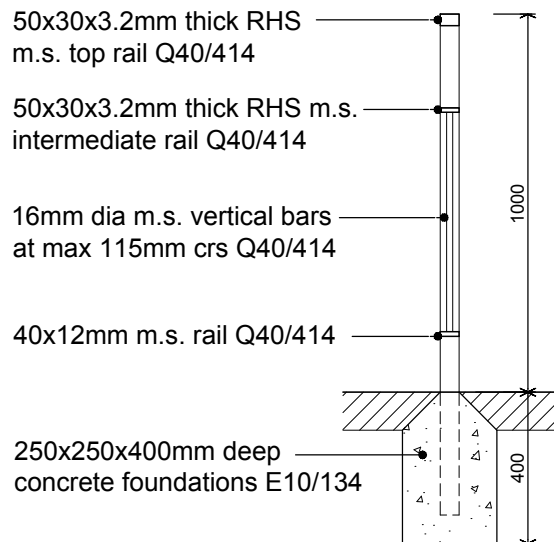

### SECTION

All mild steel components to be galvanised (Z11/360) after construction and painted after assembly on site (M60/150)



<b>TITLE</b> <b>RAILINGS</b> steel, vertical bar with separate top bar	<b>DRAWN BY</b> TJB/CB	<b>SCALE</b> 1:20	<b>DATE</b> Oct 91
	<b>DRAWING NO.</b>	A(08.10)15	
	<b>REV NO. &amp; DATE</b>	(1) 09/12	
	<b>REV NOTE:</b> Updated to revised spec		

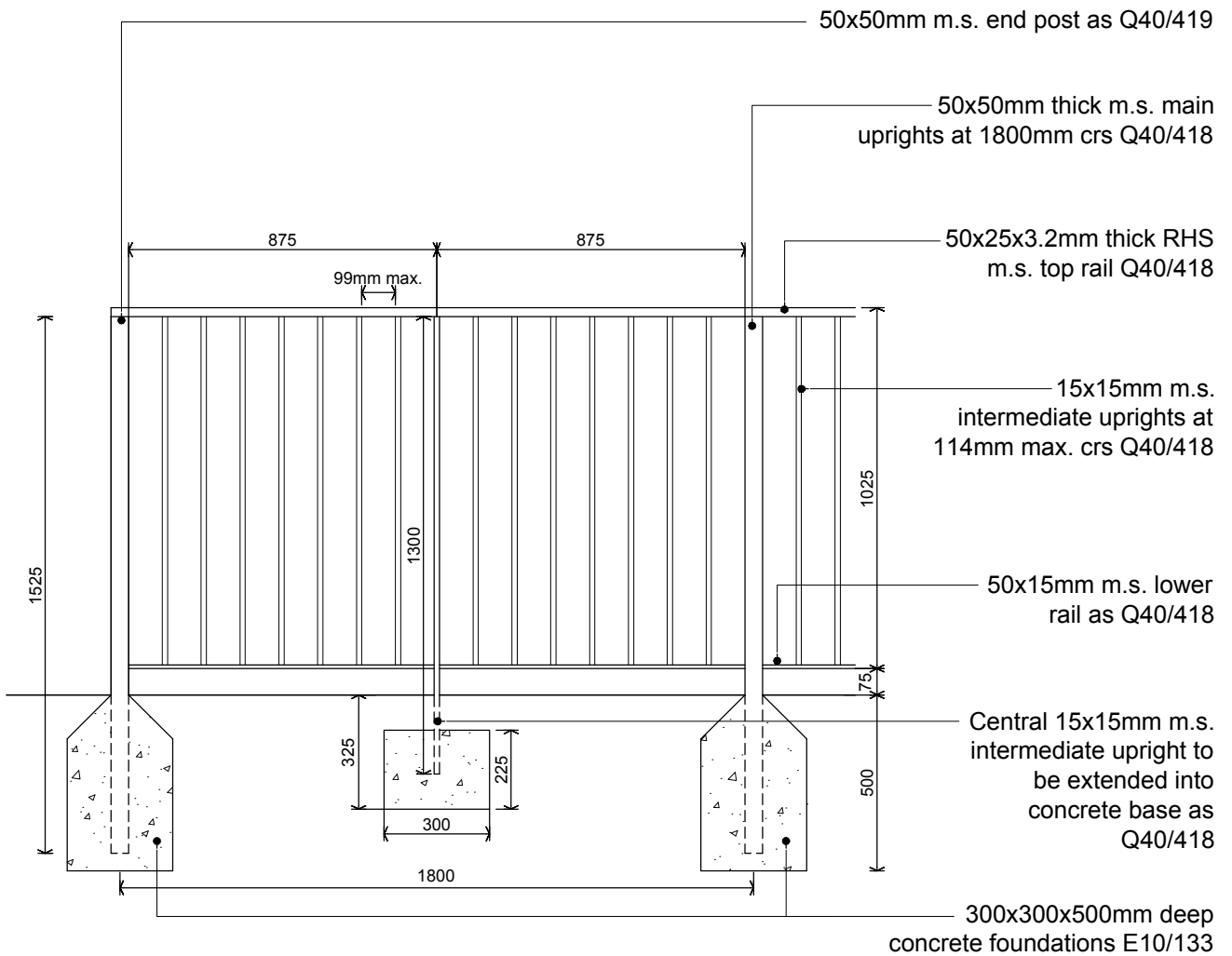

## ELEVATION

All mild steel components to be galvanised (Z11/360) after construction  
and painted after assembly on site (M60/150)

**Housing**  
Executive

TITLE  
RAILINGS  
steel, barrier type  
1100mm overall  
height

DRAWN BY  
TJB/CB

SCALE  
1:20

DATE  
Feb 92

DRAWING NO.

A(08.10)16

REV NO. & DATE

(2) 09/12

REV NOTE:

Updated to revised spec



38x38x2.6mm thick RHS galvanised m.s. intermediate posts at max 3000mm crs drilled to take stirrup wires Q40/428

50x50x3.2mm thick RHS galvanised m.s. end and corner posts as Q40/429

25x25x2.0mm thick RHS galvanised m.s. strut and brace as Q40/430

3.0mm dia core plastic coated line wires as Q40.428

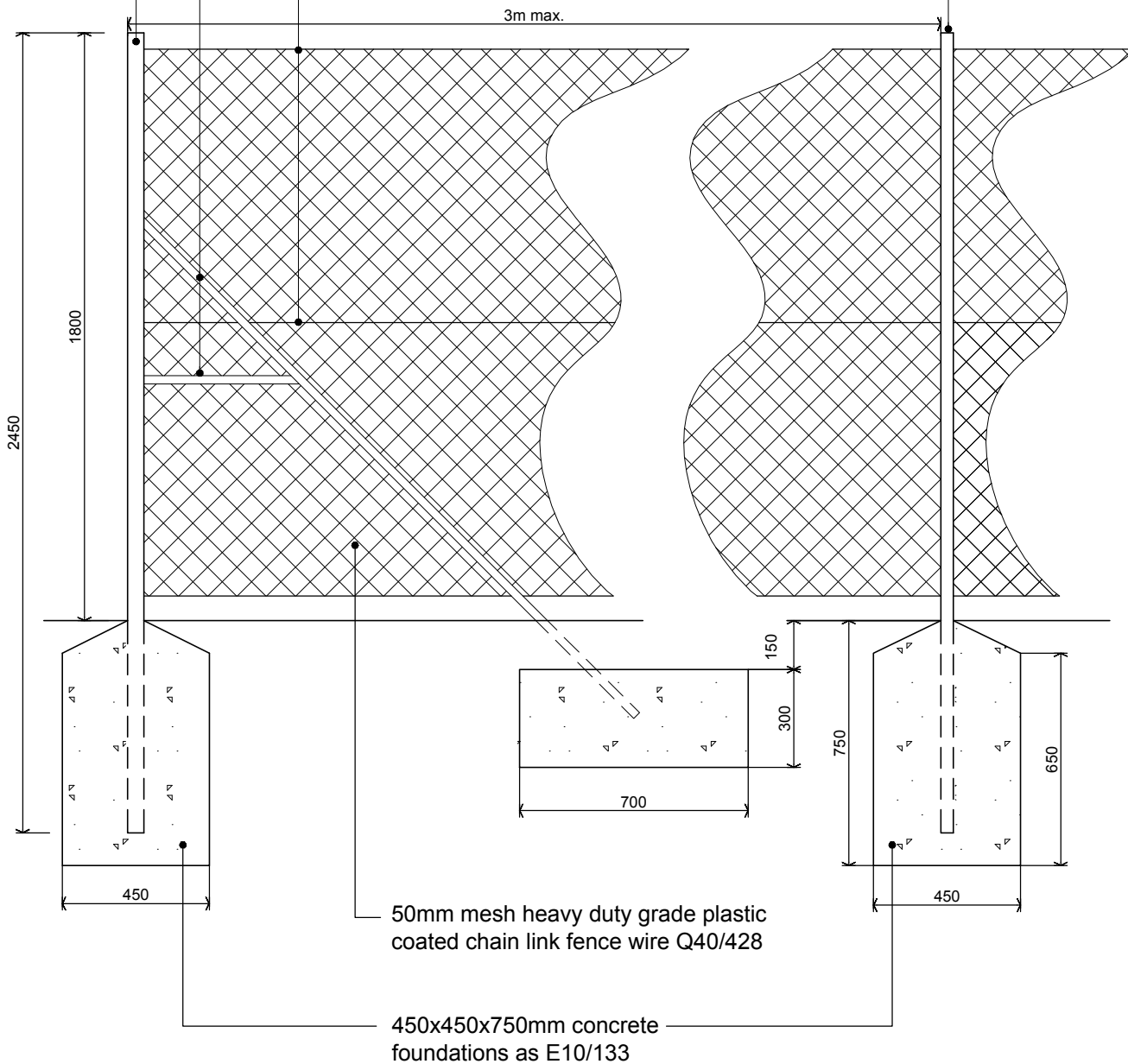

ELEVATION

© NIHE 2017 DRAWINGS NOT TO BE SCALED DUE TO PRINTING DISTORTION



<b>TITLE</b>  <b>RAILINGS</b> steel mesh	<b>DRAWN BY</b> TJB/CB	<b>SCALE</b> 1:20	<b>DATE</b> Oct 91
	<b>DRAWING NO.</b>	A(08.10)17	
	<b>REV NO. &amp; DATE</b>	(1) 09/12	
	<b>REV NOTE:</b> Updated to revised spec		

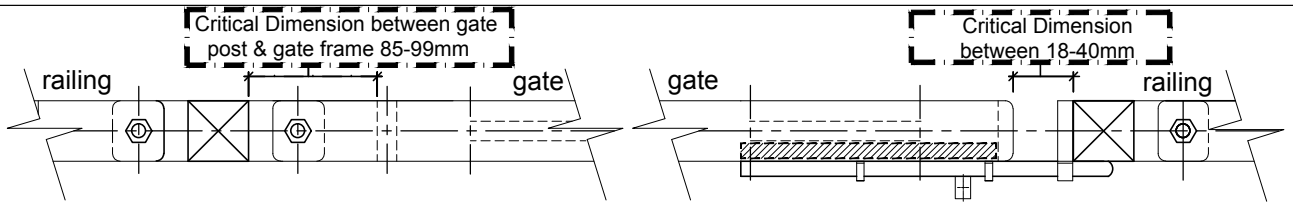

Detail A & Detail B-C - Plan of Closed Gate (1:5)

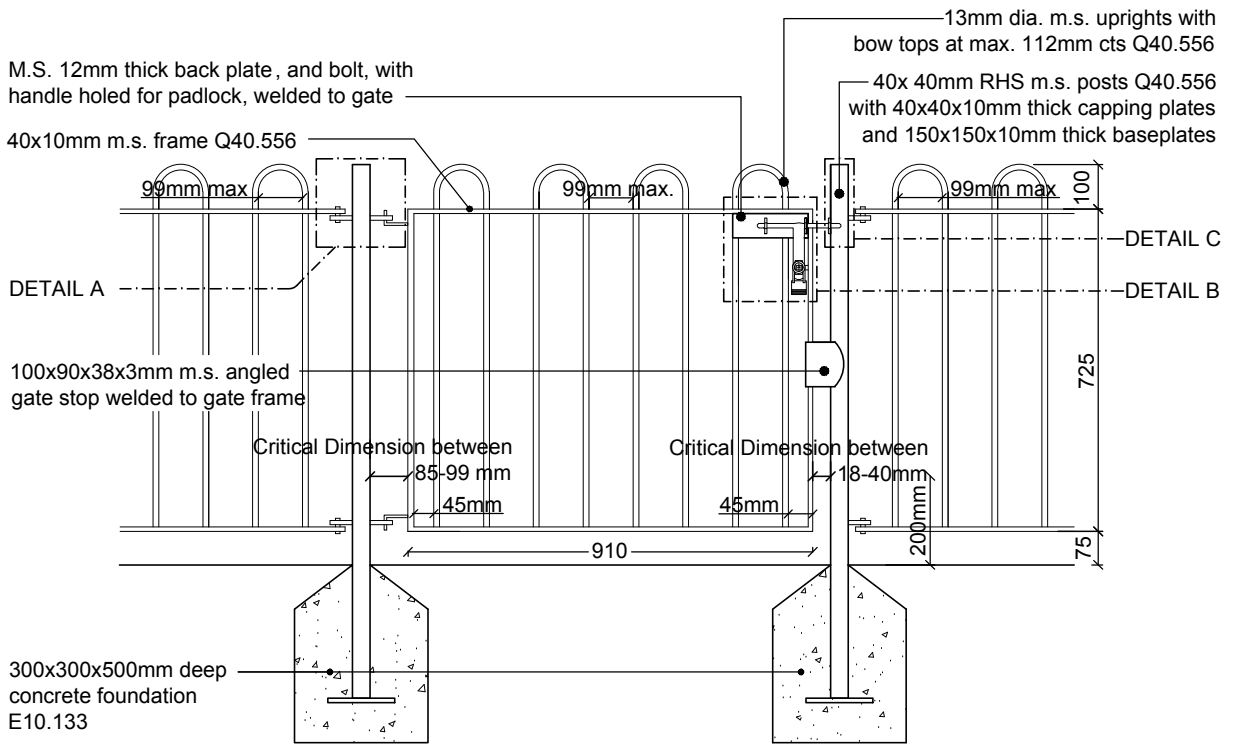
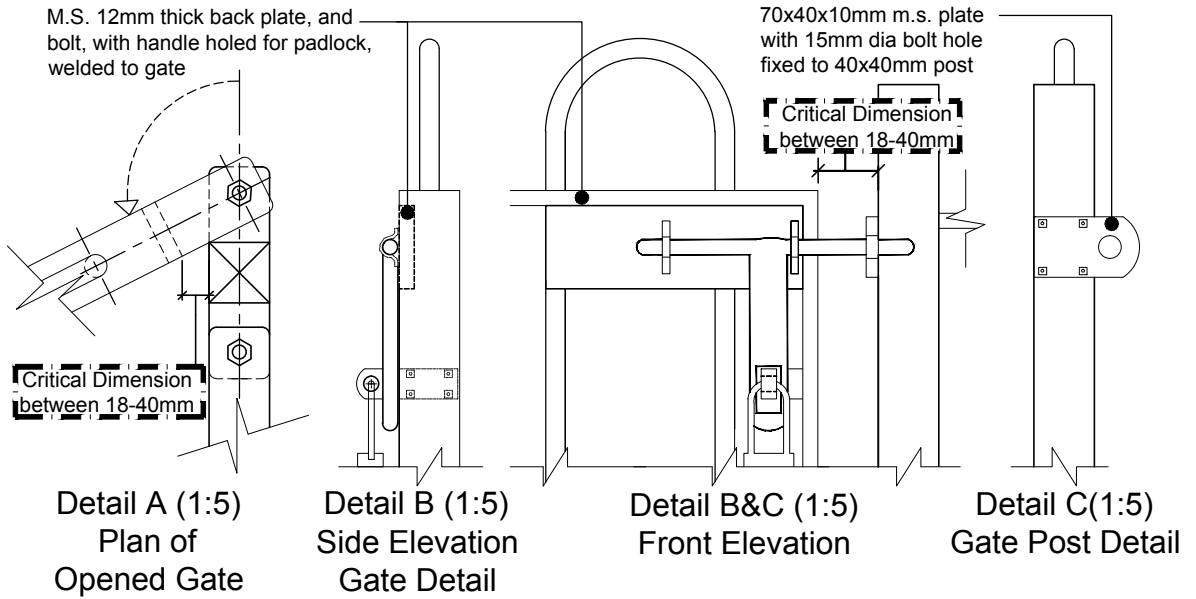

Front Elevation (Not to Scale)

**NOTES:**

- Specification Reference Q40.556
- All mild steel components to be galvanised (Z11.360) after construction and painted after assembly on site (M60.150).
- The critical dimensions are essential to avoid injury when gate is in operation.



TITLE	DRAWN BY P&S	SCALE 1:5/NTS	DATE Sept 91
STEEL, SINGLE GATE IN BOW TOPPED RAILING	DRAWING NO.	A(08.10)18	
	REV NO. & DATE	(4) 01/17	
	REV NOTE:	Updated to revised spec	



DRAWN BY P&S	SCALE 1:5/NTS	DATE Sept 91
DRAWING NO.	A(08.10)18	
REV NO. & DATE	(4) 01/17	
REV NOTE:	Updated to revised spec	

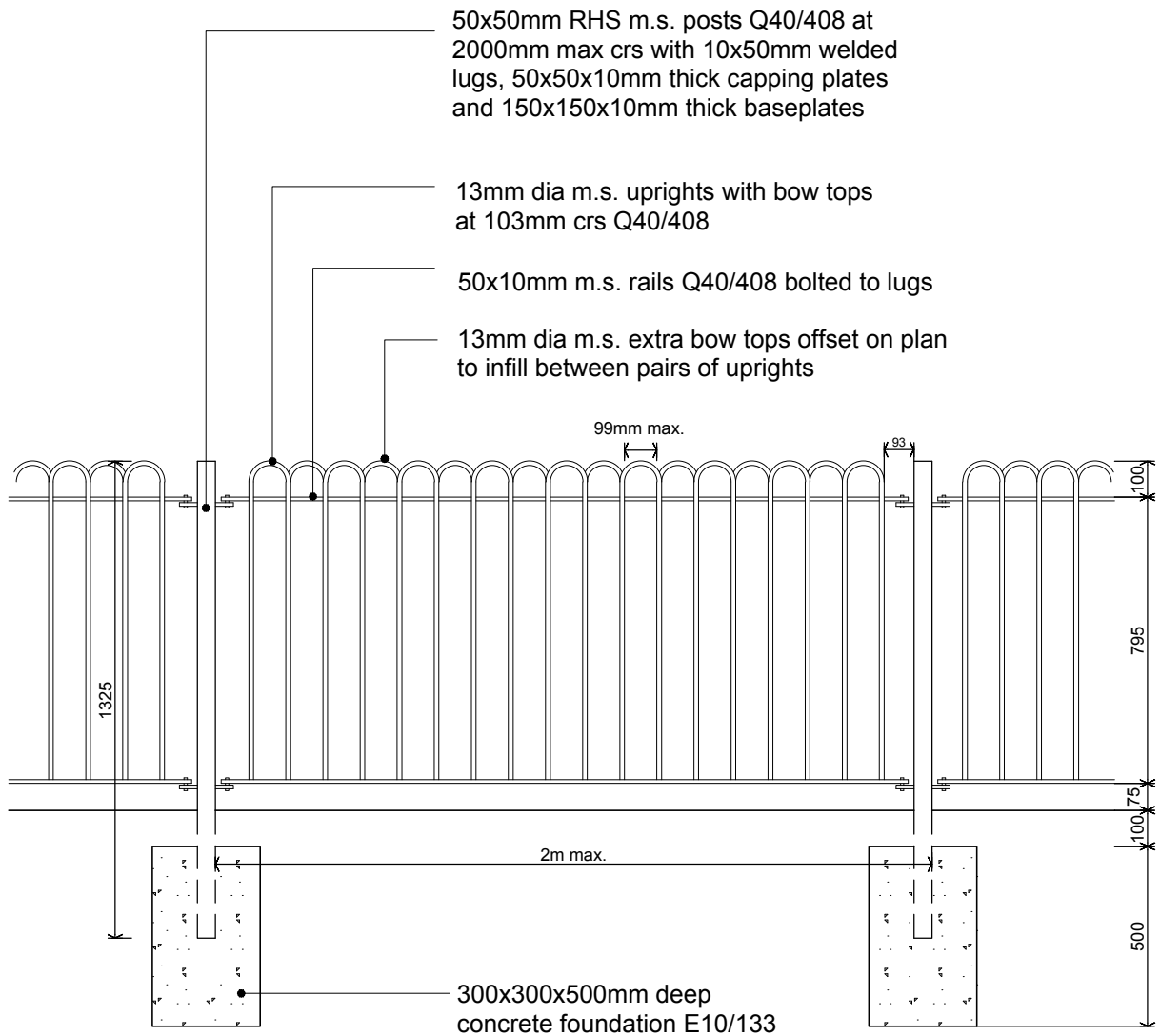



## ELEVATION

All mild steel components to be galvanised (Z11/360) after construction and painted after assembly on site (M60/150)

	TITLE	DRAWN BY <b>P&amp;S</b>	SCALE <b>1:20</b>	DATE <b>Oct 91</b>
	<b>RAILINGS</b> steel double bow topped	DRAWING NO.	<b>A(08.10)19</b>	
		REV NO. & DATE	<b>(3) 02/15</b>	
		REV NOTE:	<b>Top Rail Lowered</b>	
				

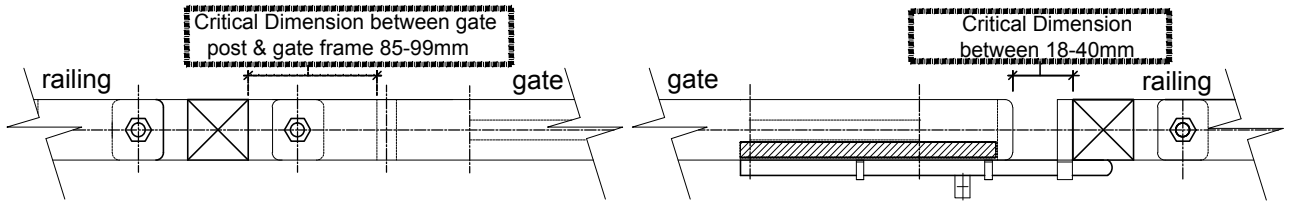

Detail A & Detail B-C - Plan of Closed Gate (1:5)

M.S. 12mm thick back plate, and bolt, with handle holed for padlock, welded to gate

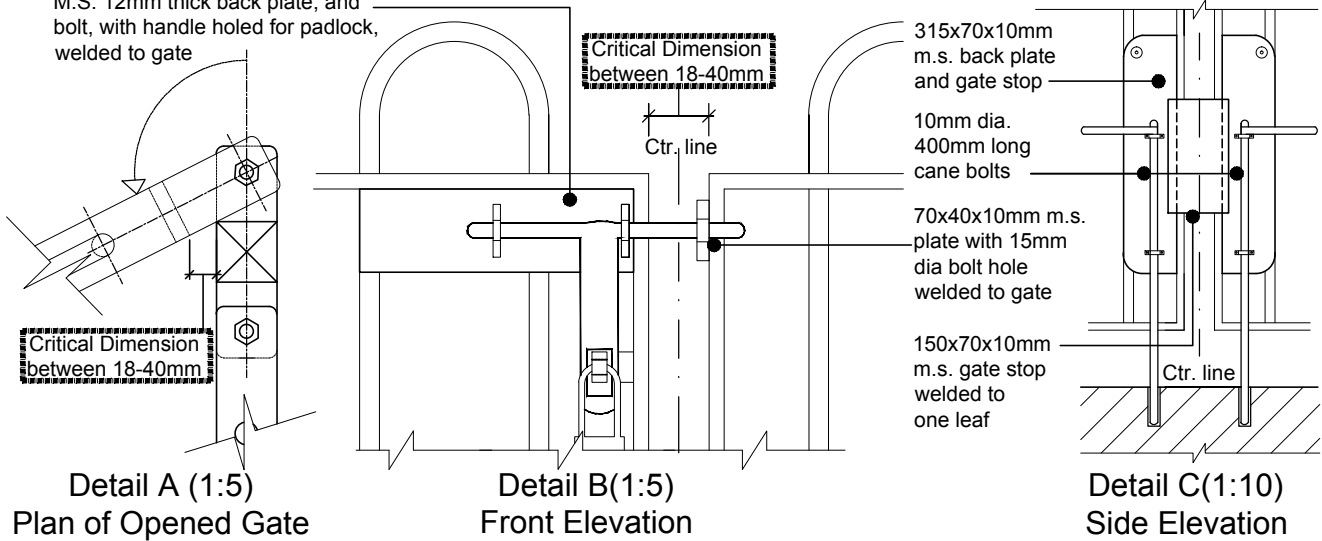

M.S. 12mm thick back plate, and bolt, with handle holed for padlock, welded to gate

40x10mm m.s. frame Q40/557

13mm thick dia. m.s. uprights with bow tops at 112mm cts Q40.557

40x40mm RHS m.s. post Q40.557 with 40x40x10mm thick capping plates and 150x150x10mm thick baseplates

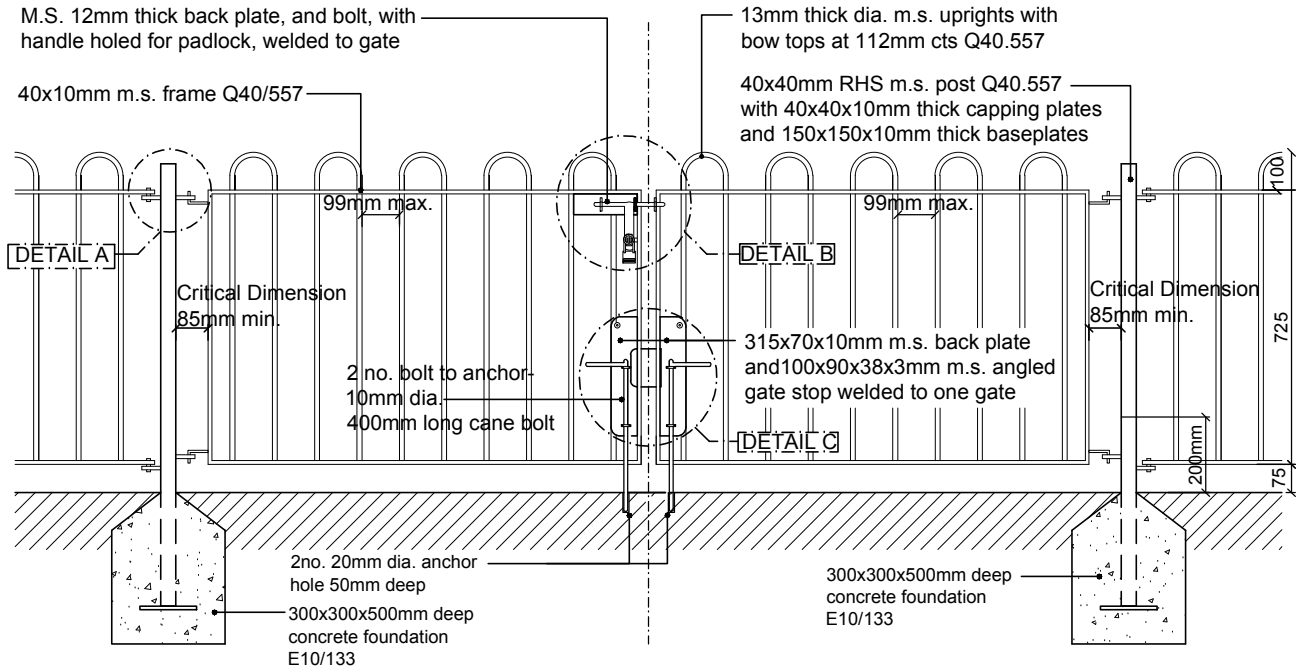

Front Elevation (NTS)

NOTES:

- Specification Reference Q40.557
- All mild steel components to be galvanised (Z11.360) after construction and painted after assembly on site (M60.150).
- The critical dimensions are essential to avoid injury when gates are in operation.



<p>TITLE</p> <p>Steel Double Gates in bow topped railings</p>	<p>DRAWN BY</p> <p>P&amp;S</p>	<p>SCALE</p> <p>1:5/NTS</p>	<p>DATE</p> <p>Nov 91</p>
	<p>DRAWING NO.</p>	<p>A(08.10)20</p>	
	<p>REV NO. &amp; DATE</p>	<p>(4) 01/17</p>	
	<p>REV NOTE:</p> <p>Updated to revised spec</p>		

20x144 treated sw vertical boards @ 437mm centres infill with 2 No 20x72 evenly spaced vertical boards (with 50mm space between each board) Q40/125

44x69 splayed treated SW runners Q40/130

50mm concrete paving or asphalt to DOE specification Q22/Q24

75mm blinded hardcore

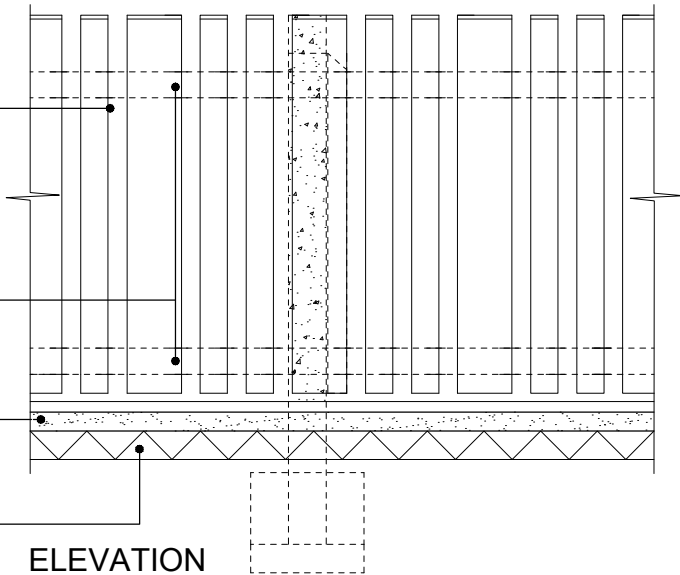

100 x 100 precast conc. post & 100 x 50mm treated softwood timber

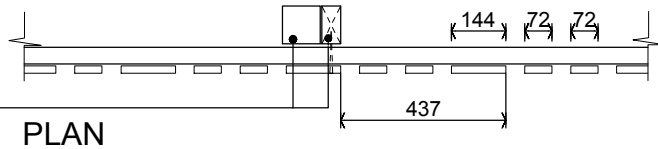

44x69 Splayed treated SW runners Q40/130  
20x144 (wide) and 20x72 infill (narrow) treated sw vertical boards splayed top and bottom Q40/125

50x150 concrete kerb Q10/118

300x300 concrete around posts

75mm concrete foundation

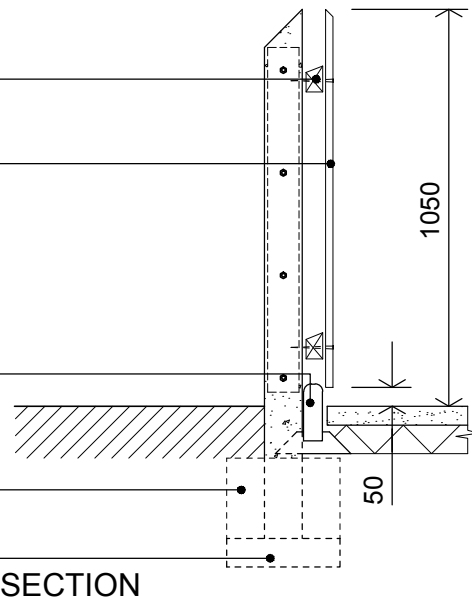

UNPROTECTED AND /OR EXPOSED FENCING LOCATIONS-  
Bullwire to be stapled over vertical boarding at ledging and bracing, Q40/133 to employers' discretion

© NIHE 2017  
DRAWINGS NOT TO BE SCALED DUE TO PRINTING DISTORTION



TITLE	1050 TIMBER FENCE (Double Narrow Board)		
-------	--	--	--

DRAWN BY	SCALE	DATE
P&S	1:20	Aug 98
DRAWING NO.	A(08.10)21	
REV NO. & DATE	(1) Feb 2015	
REV NOTE:	Update for revised spec	



20x144 Treated SW vertical boards @560mm centres  
infill with 3 No 20x72 vertical boards @ 122mm centres (with 50mm space between each board) Q40/126

44x69 Splayed treated SW runners Q40/130

50mm concrete paving or asphalt to DOE specification Q22/Q24

75mm blinded hardcore

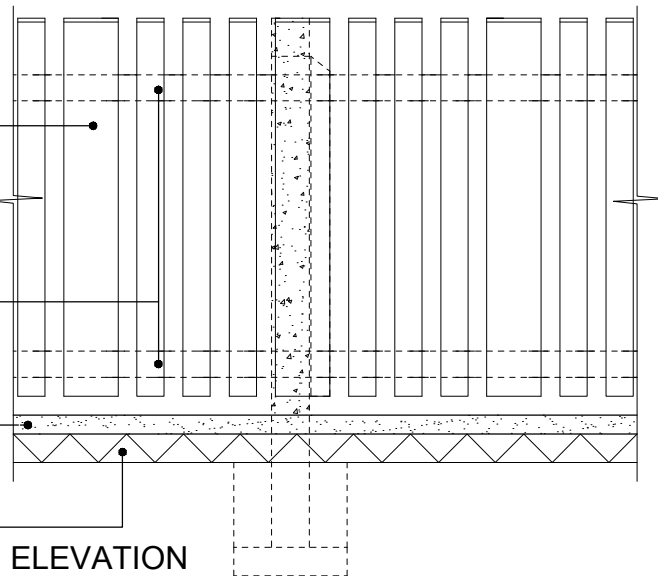

100 x 100 precast conc. post & 100 x 50mm treated softwood timber

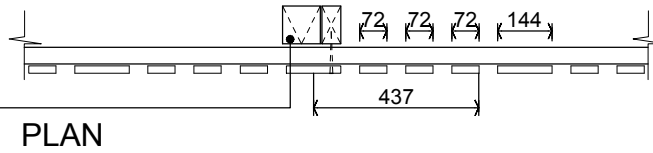

44x69 Splayed treated SW runners Q40/130

20x144 (wide) and 20x72 infill (narrow) Treated SW vertical boards splayed top and bottom Q40/126

50x150 Concrete kerb Q10/118

300x300 concrete around posts

75mm concrete foundation

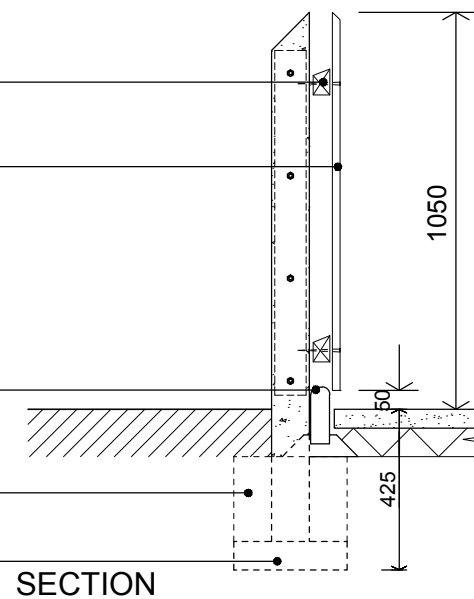

UNPROTECTED AND /OR EXPOSED FENCING LOCATIONS-  
Bullwire to be stapled over vertical boarding at  
ledging and bracing, Q40/133 to employers' discretion

© NIHE 2017  
DRAWINGS NOT TO BE SCALED DUE TO PRINTING DISTORTION



TITLE  <b>1050 TIMBER FENCE (Triple Narrow Board)</b>	DRAWN BY <b>P&amp;S</b>	SCALE <b>1:20</b>	DATE <b>Aug 98</b>
	DRAWING NO. <b>A(08.10)22</b>		
	REV NO. & DATE <b>(1) Feb 2015</b>		
	REV NOTE: <b>Updated for revised spec</b>		



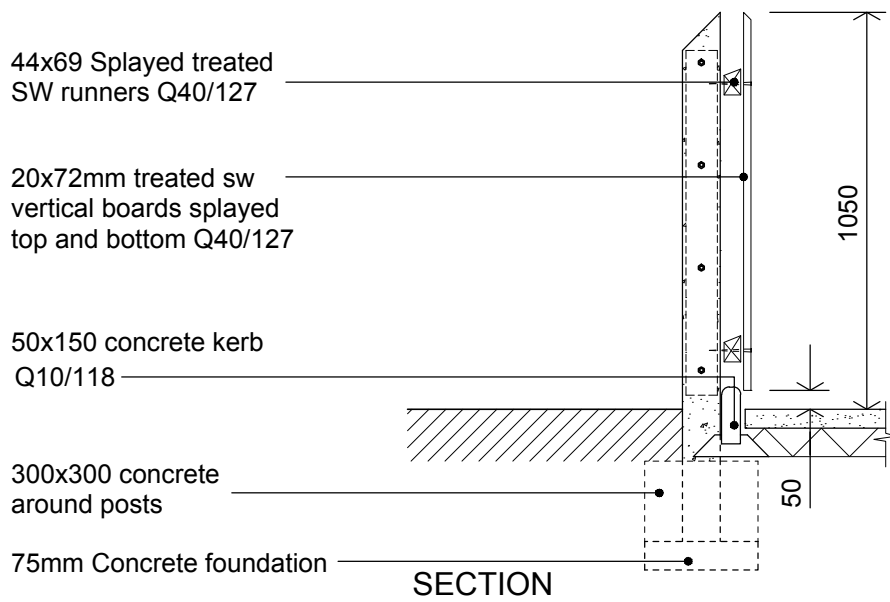
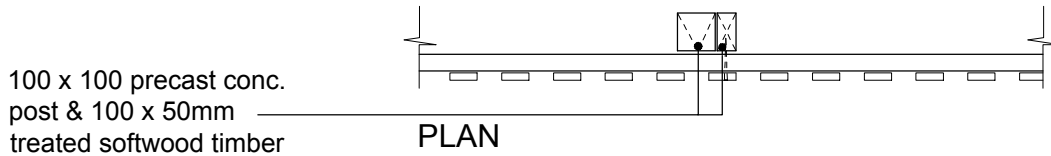
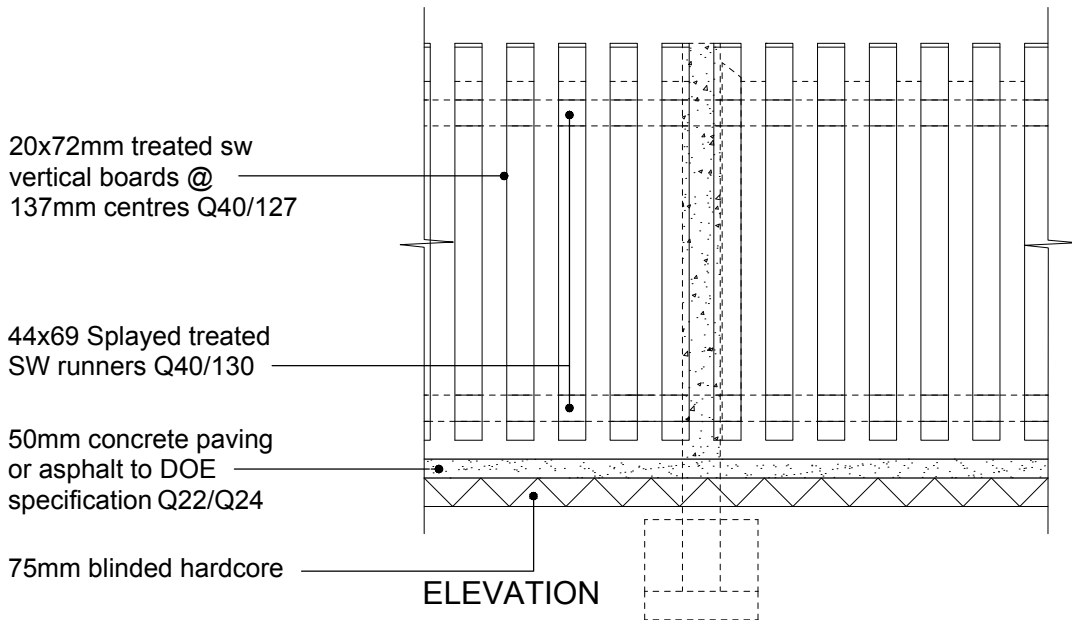

© NIHE 2017  
DRAWINGS NOT TO BE SCALED DUE TO PRINTING DISTORTION



TITLE <b>1050 TIMBER FENCE (Picket)</b>	DRAWN BY <b>TJB</b>	SCALE <b>1:20</b>	DATE <b>Aug 98</b>
	DRAWING NO. <b>A(08.10)23</b>		
	REV NO. & DATE <b>(1) Feb 2015</b>		
	REV NOTE: <b>Updated for revised spec</b>		

Alternative 1000mm/650mm long  
20x72mm treated sw  
vertical boards @  
137mm centres Q40/128

44x69 Splayed treated  
SW runners Q40/130

50mm concrete paving  
or asphalt to DOE  
specification Q22/Q24

75mm blinded hardcore

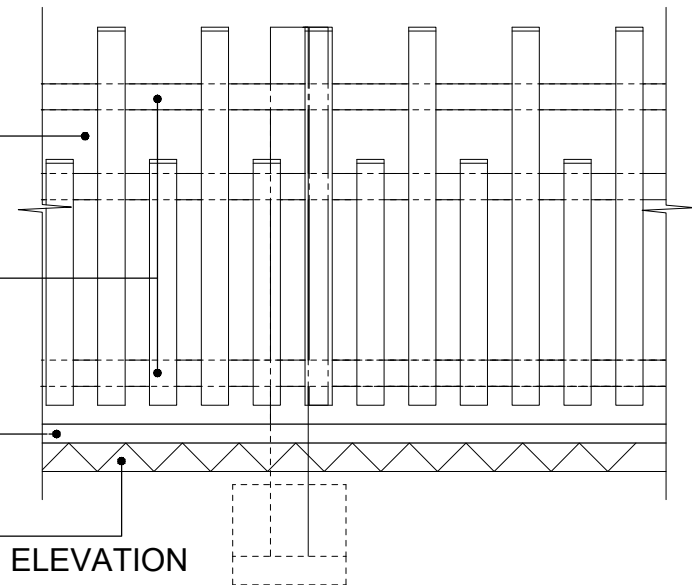

100 x 100 precast conc.  
post & 100 x 50mm  
treated softwood timber

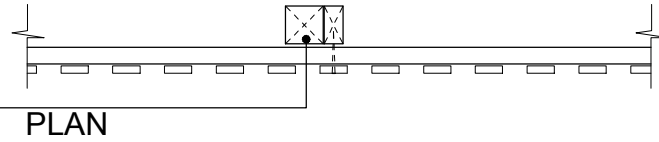

44x69 Splayed treated  
SW runners Q40/128

20x72mm Treated SW  
vertical boards splayed  
top and bottom Q40/128

50x150 Concrete kerb  
Q10/118

300x300 Concrete  
around posts

75mm Concrete foundation

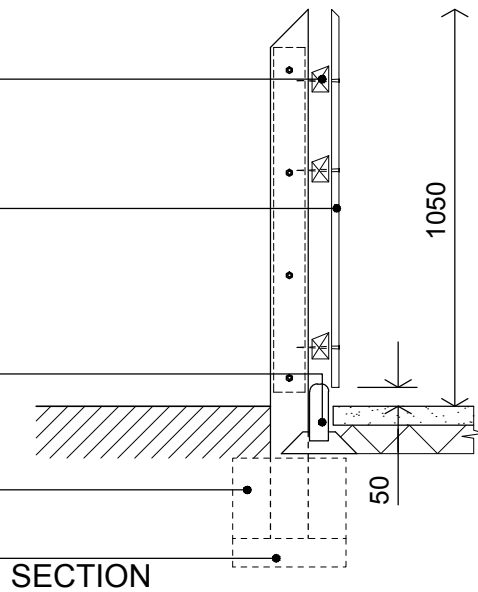

© NIHE 2017  
DRAWINGS NOT TO BE SCALED DUE TO PRINTING DISTORTION



<p>TITLE</p> <p><b>1050 TIMBER FENCE (Staggered Picket Top)</b></p>	<p>DRAWN BY</p> <p><b>P&amp;S</b></p>	<p>SCALE</p> <p><b>1:20</b></p>	<p>DATE</p> <p><b>Aug 98</b></p>
	<p>DRAWING NO.</p>	<p><b>A(08.10)24</b></p>	
	<p>REV NO. &amp; DATE</p>	<p><b>(1) Feb 2015</b></p>	
	<p>REV NOTE:</p> <p><b>Updated for revised spec</b></p>		

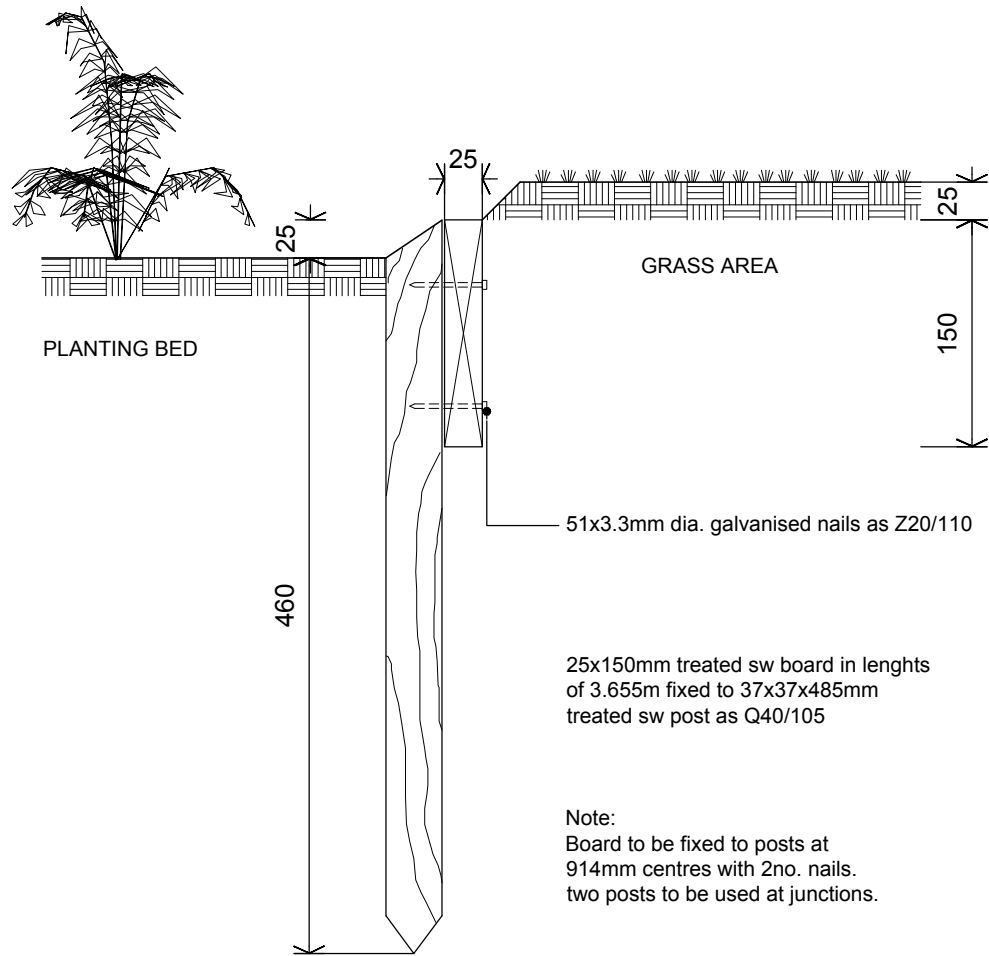

SECTION



<p>TITLE</p> <p><b>BOARD EDGING TO PLANTED BEDS/ GRASS AREAS</b></p>	<p>DRAWN BY</p> <p><b>TJB</b></p>	<p>SCALE</p> <p><b>1:5</b></p>	<p>DATE</p> <p><b>Sept 00</b></p>
	<p>DRAWING NO.</p>	<p><b>A(08.10)26</b></p>	
	<p>REV NO. &amp; DATE</p>		
	<p>REV NOTE:</p>		

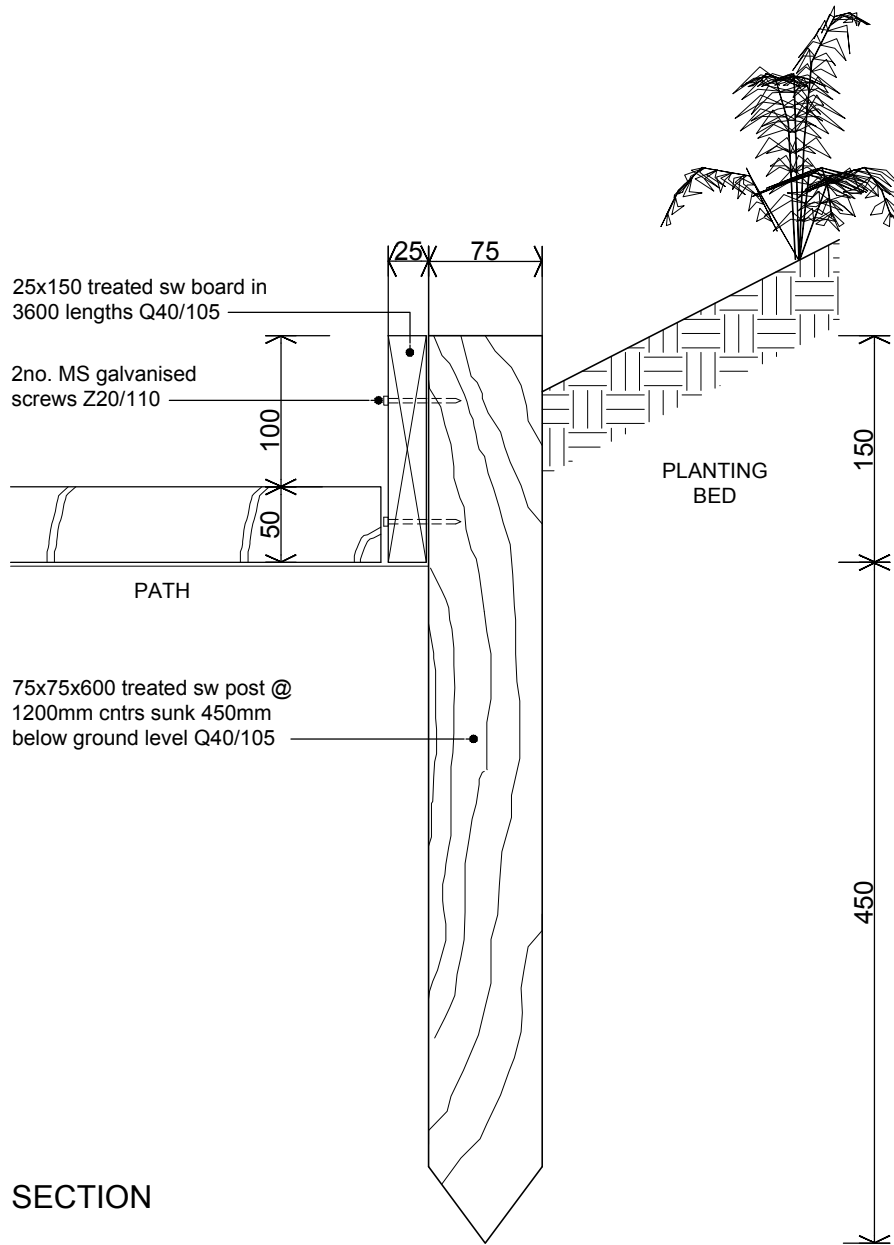

<b>TITLE</b> BOARD EDGING TO PLANTED BEDS/ PATHWAY	<b>DRAWN BY</b> TJB	<b>SCALE</b> 1:5	<b>DATE</b> Sept 00
	<b>DRAWING NO.</b>	A(08.10)27	
	<b>REV NO. &amp; DATE</b>	(1) 8/04	
	<b>REV NOTE:</b>		

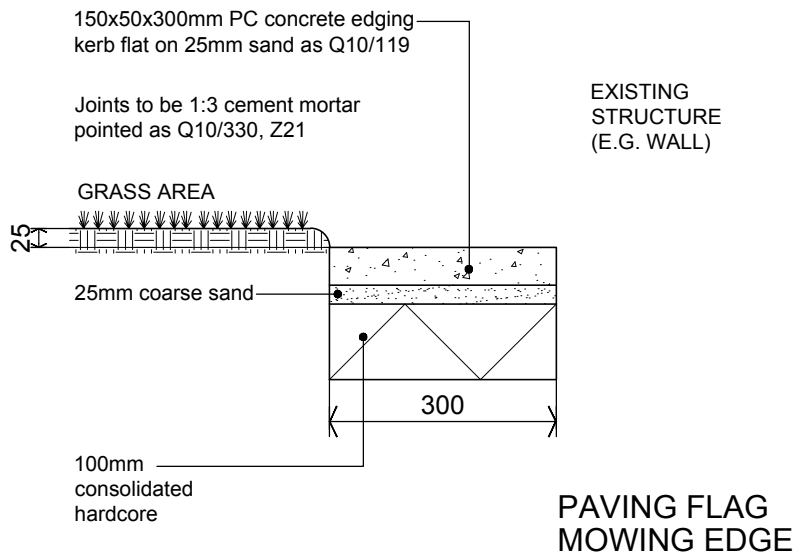
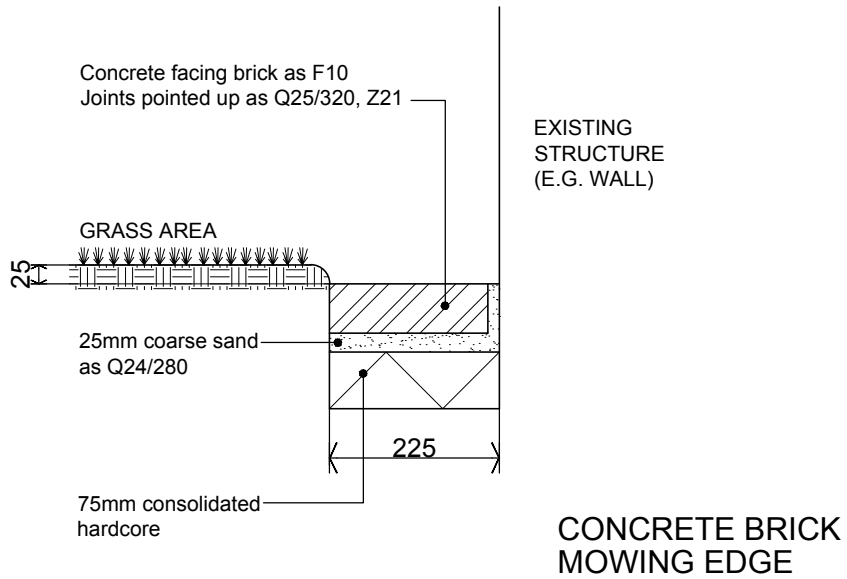

TITLE  
**PAVING EDGING TO  
 PLANTED BEDS/  
 GRASS AREAS**

DRAWN BY <b>TJB</b>	SCALE <b>1:10</b>	DATE <b>Sept 00</b>
DRAWING NO.	<b>A(08.10)28</b>	
REV NO. & DATE		
REV NOTE:		



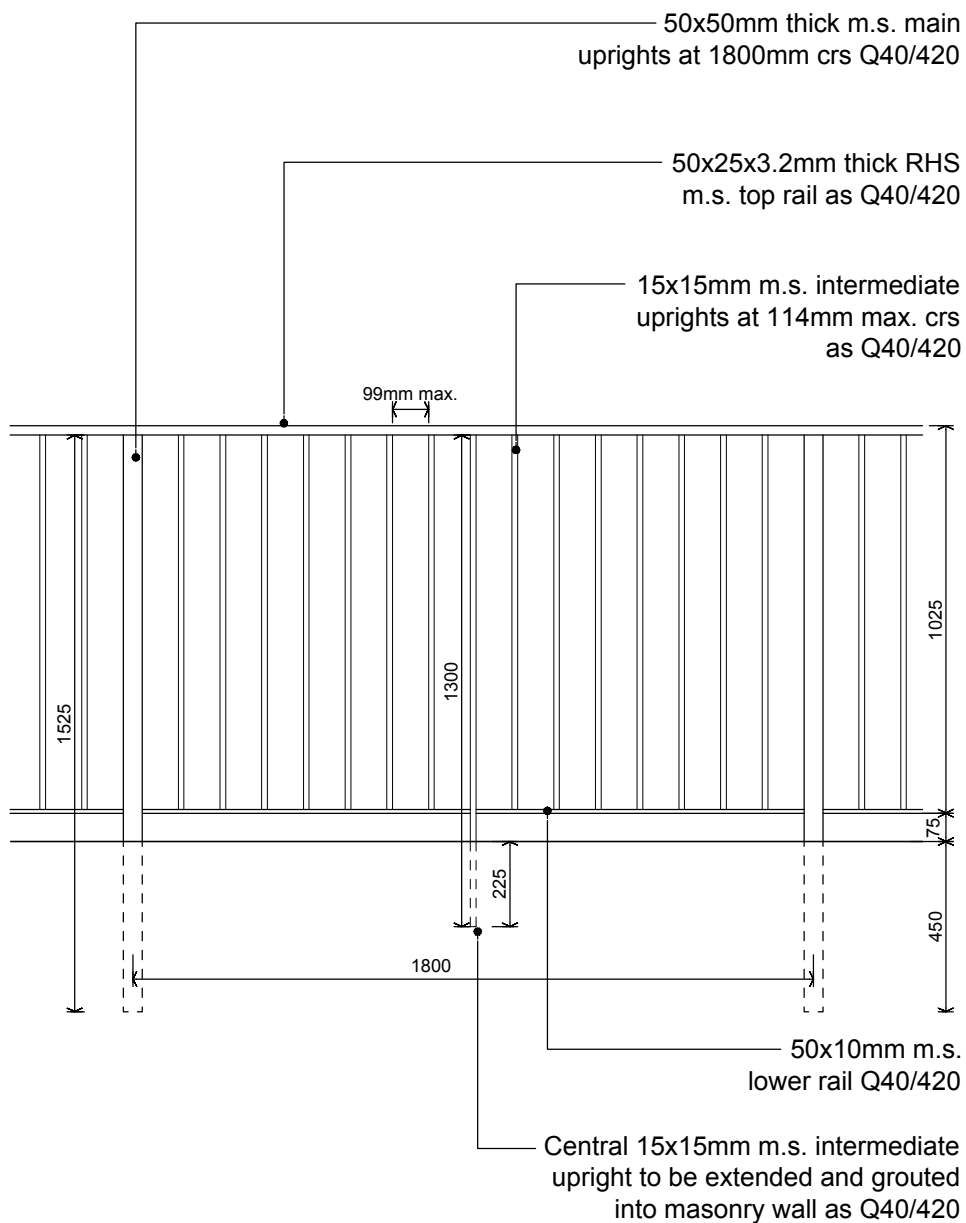

Fixing to masonry ragged ends of main verticals grouted into 75mm dia x 450mm deep pockets drilled into top of existing or new 215mm thick masonry retaining walls

ELEVATION

All mild steel components to be galvanised (Z11/360) after construction and painted after assembly on site (M60/150)



TITLE  
Galvanised Steel Safety Railings 1100mm height above wall

DRAWN BY CgR/AD/CB	SCALE 1:20	DATE Sept 07
DRAWING NO.	A(08.10)29	
REV NO. & DATE	(1) 09/12	
REV NOTE: Updated to revised spec		



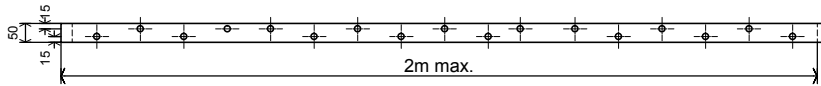

PLAN - Staggered Infill Panel

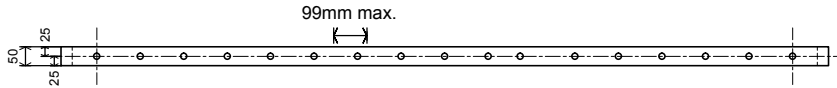

PLAN - Standard Infill Panel

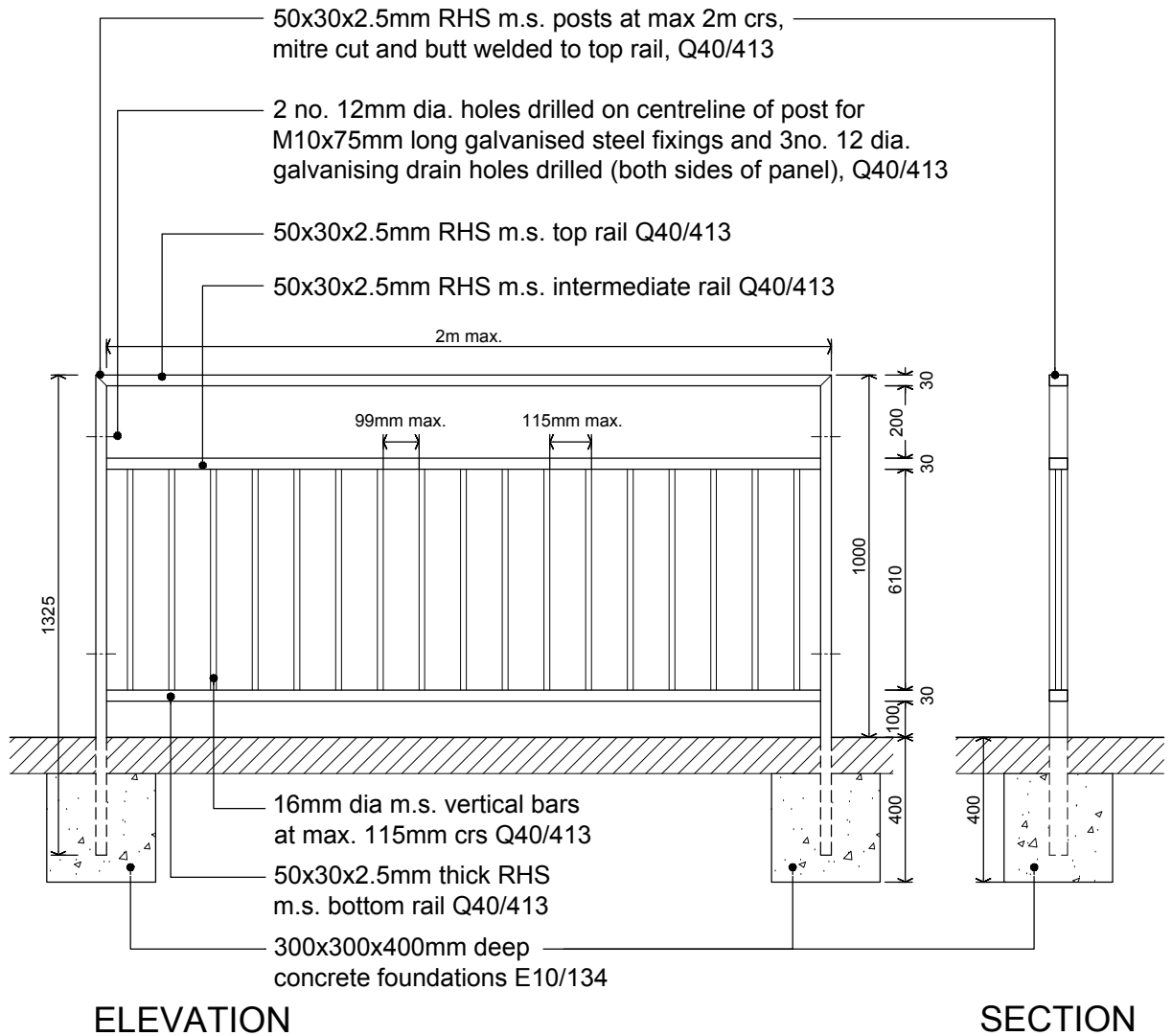

All mild steel components to be galvanised (Z11/360) after construction

© NIHE 2017  
DRAWINGS NOT TO BE SCALED DUE TO PRINTING DISTORTION



TITLE	DRAWN BY	SCALE	DATE
PEDESTRIAN GUARD RAIL	CB	1:20	Sept 12
	DRAWING NO.	A(08.10)31	
	REV NO. & DATE		
	REV NOTE:		

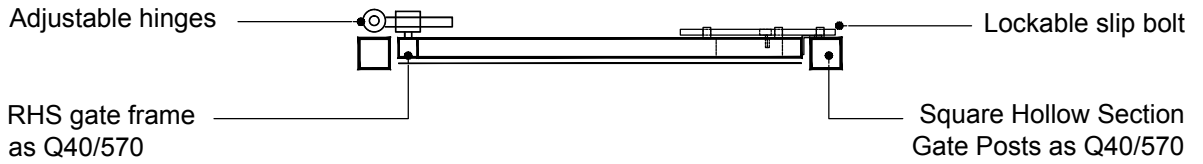

OUTSIDE FACE

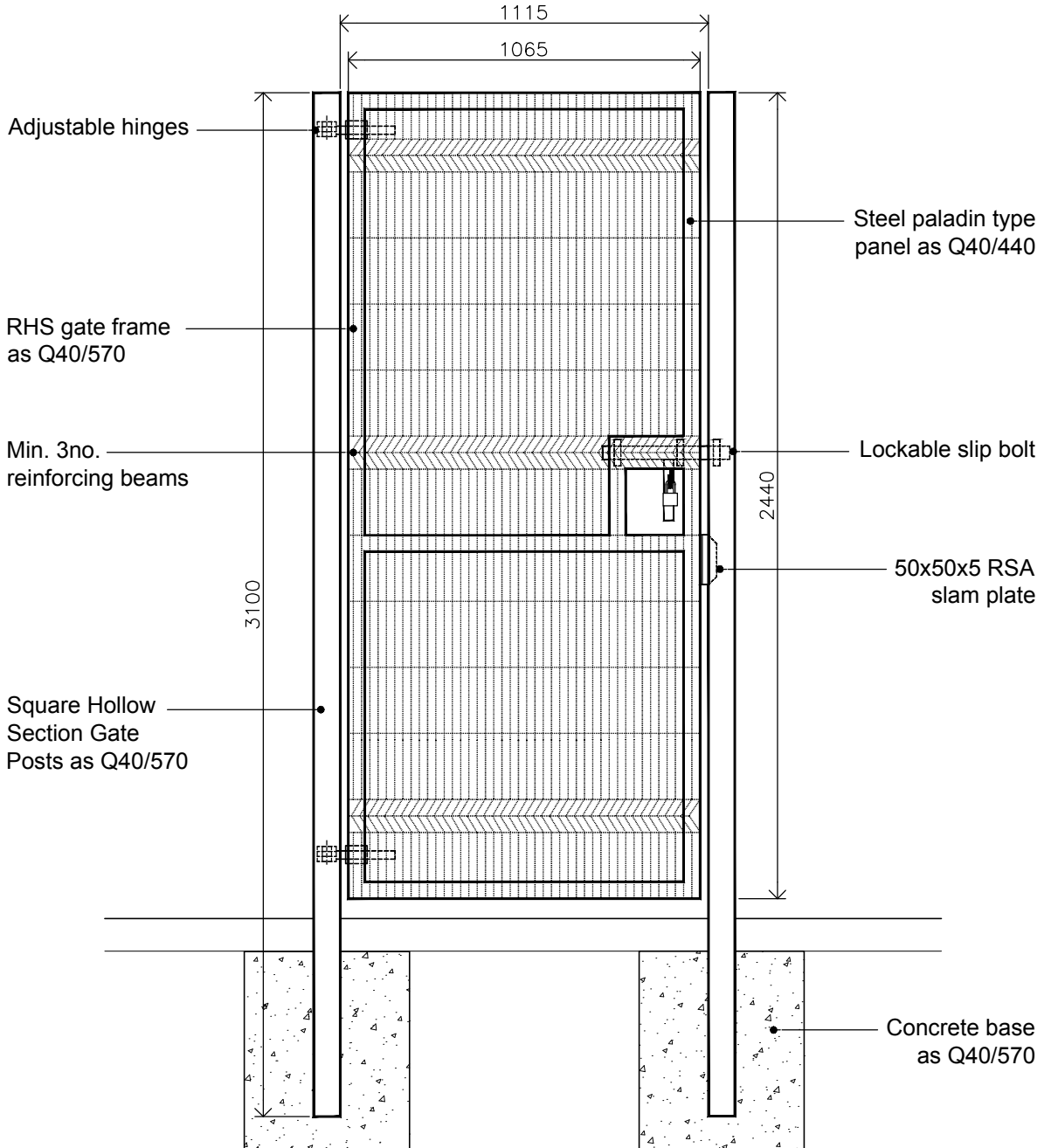

Finish: Galvanised as Z11/360 and polyester powder coated as Z31  
 Colour: Irish green as Q40.570

© NIHE 2017  
 DRAWINGS NOT TO BE SCALED DUE TO PRINTING DISTORTION



TITLE	DRAWN BY	SCALE	DATE
PALADIN PEDESTRIAN GATE (SINGLE)	CB	1:20	Sept 12
	DRAWING NO.	C(08.10)06	
	REV NO. & DATE		
	REV NOTE:		

DRAWN BY	SCALE	DATE
CB	1:20	Sept 12
DRAWING NO.	C(08.10)06	
REV NO. & DATE		
REV NOTE:		





**Housing**  
Executive

**PALADIN GATE (DOUBLE)**

TITLE

DRAWN BY  
**CB**

SCALE  
**NTS**

DATE  
**Sept 12**

DRAWING NO.  
**C(08.10)07**

REV NO. & DATE  
**(1) 04/13**

REV NOTE:  
**Title amended**

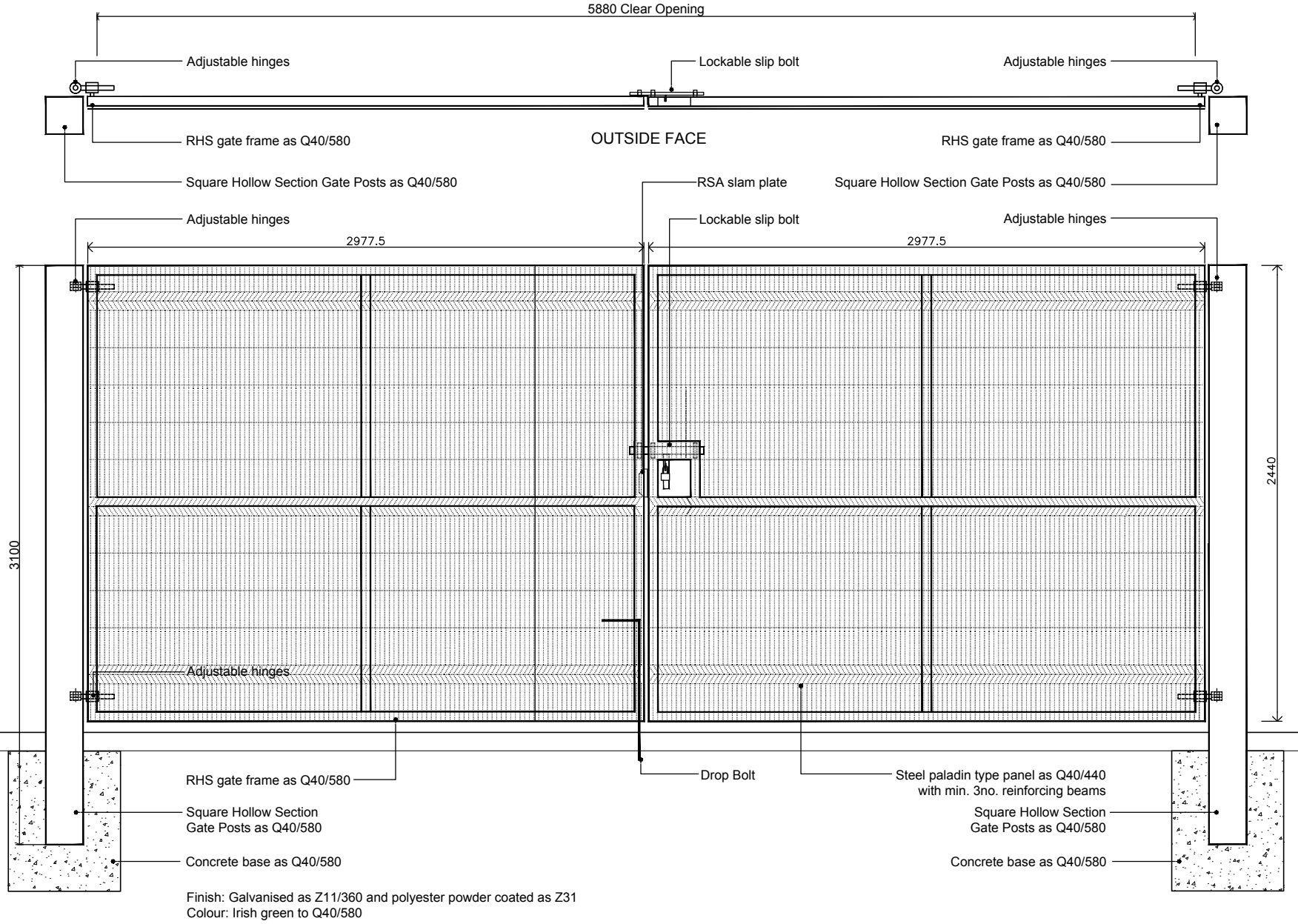

\* This NIHE produced detail has been examined by The Building Control N.I. Standards Panel and has been considered reasonable in its interpretation of the relevant requirements of the Building Regulation NI 2012. There is no legal obligation for any Building Control department to adopt this recommendation & it is subject to revision in the event of changes to the legislation or other mitigating circumstances.

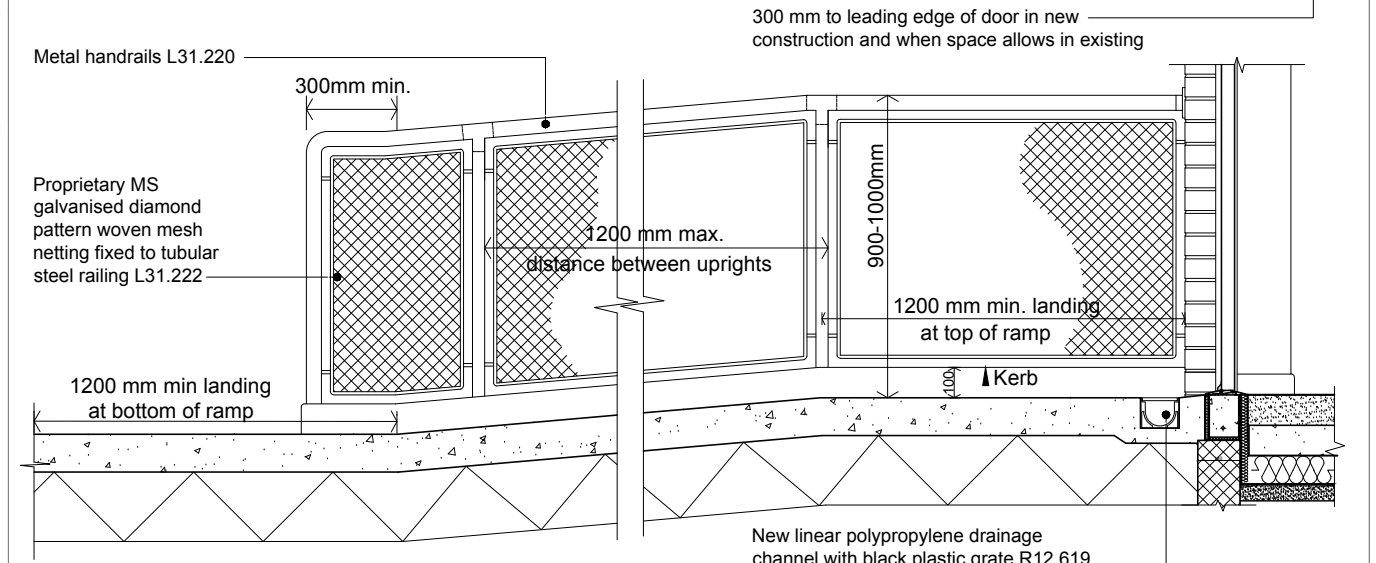
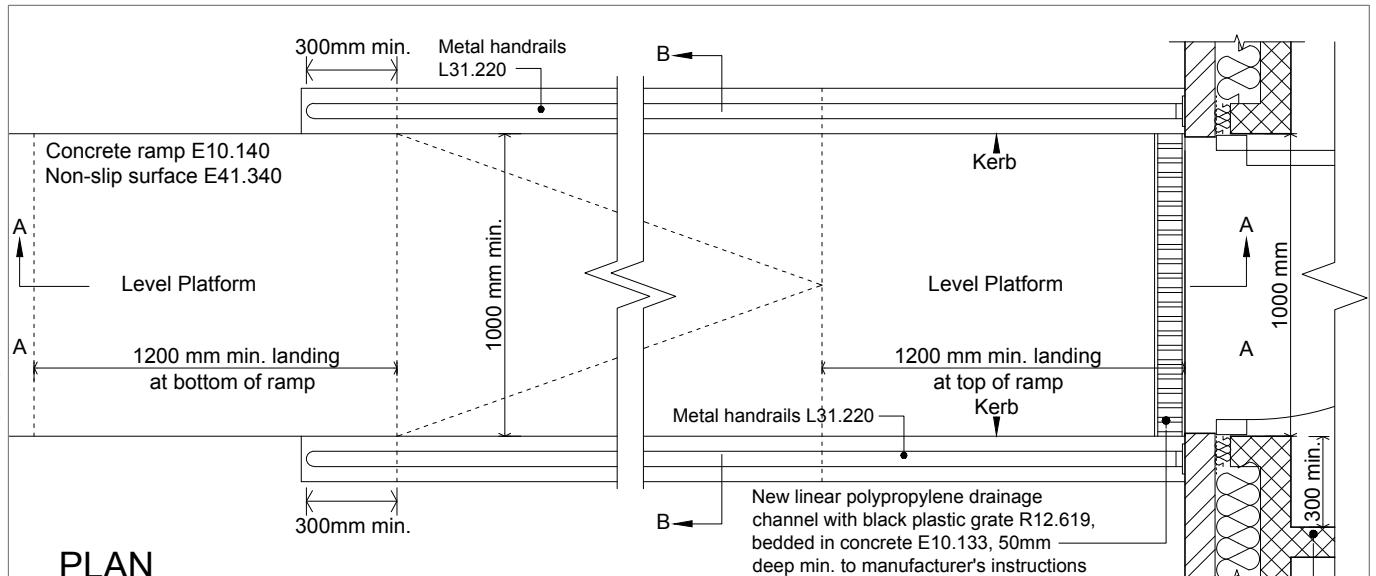

**NOTES:**

Ramps, handrails etc. to comply with current Building Regulations, Technical Booklet H.

**Ramps:**

- Gradient no steeper than 1:12.
- Cross-fall no greater than 1:40.
- The length of a ramp measured on plan, may not exceed 10m long at 1:15 or 5m long at 1:12.
- If the above lengths cannot be achieved, a resting platform of at least 1500 mm long must be provided.

**Handrails:**

- 48.3mm galvanised circular hollow sections.
- Must terminate in a closed end.
- Must be continuous for length of the ramp.
- Should be securely fixed in accordance with manufacturer's instructions.
- A ramp or a series of ramps with a total rise of more than 600 mm should have a continuous handrail
- guarding to resist a horizontal force of 0.74kN/m.

**Level Access:**

- See A(02.11)03 for existing threshold.
- See A(02.11)19 for new threshold.

\* To be confirmed by Occupational Therapist.

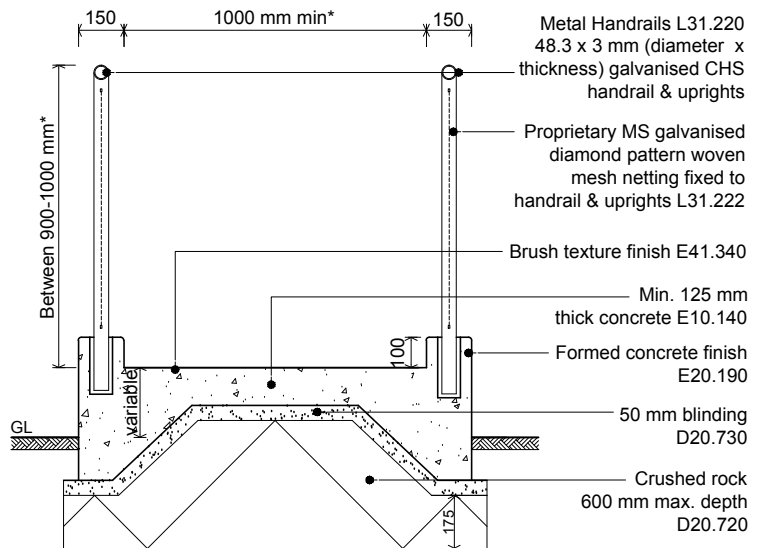

**SECTION B:B (1:25)**

<p><b>Housing Executive</b></p> <p><i>BCNI Standards Panel Agreed *</i></p>	TITLE	DRAWN BY	SCALE	DATE
	DETAIL OF RAMP ACCESS TO DWELLINGS	P&S	1:25	Apr 91
		DRAWING NO.	A(08.11)01	
		REV NO. & DATE	(5) 02/15	
	REV NOTE:	Updated to Revised Spec & APD Toolkit		

© NIHE 2017 DRAWINGS NOT TO BE SCALED DUE TO PRINTING DISTORTION

\* This NIHE produced detail has been examined by The Building Control N.I. Standards Panel and has been considered reasonable in its interpretation of the relevant requirements of the Building Regulation NI 2012. There is no legal obligation for any Building Control department to adopt this recommendation & it is subject to revision in the event of changes to the legislation or other mitigating circumstances.

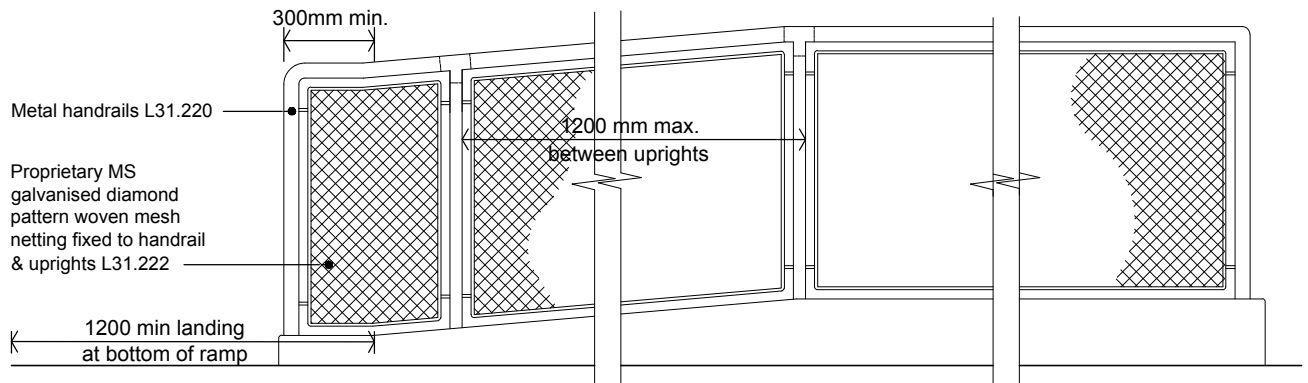
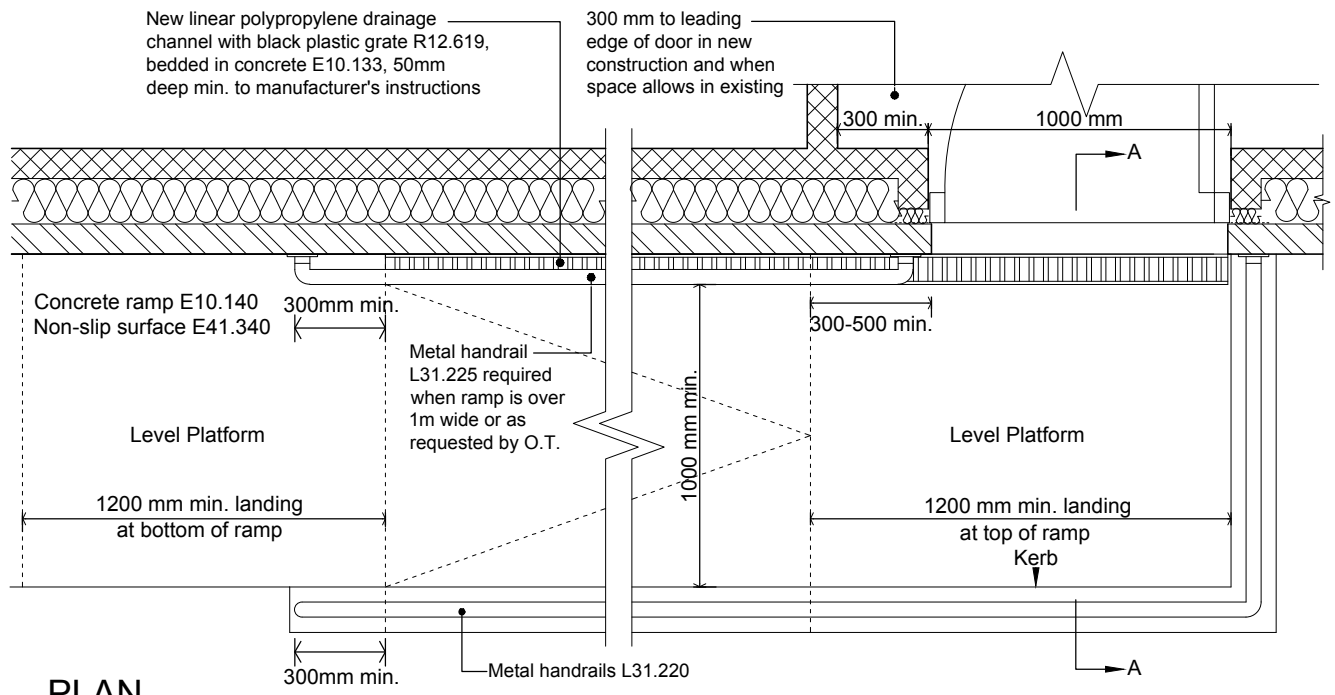

**NOTES:**

Ramps, handrails etc. to comply with current Building Regulations, Technical Booklet H.

**Ramps:**

- Gradient no steeper than 1:12.
- Cross-fall no greater than 1:40.
- The length of a ramp measured on plan, may not exceed 10m long at 1:15 or 5m long at 1:12.
- If the above lengths cannot be achieved, a resting platform of at least 1500 mm long must be provided.

**Handrails:**

- 48.3mm galvanised circular hollow sections.
- Must terminate in a closed end.
- Must be continuous for length of the ramp.
- Should be securely fixed in accordance with manufacturer's instructions.
- A ramp or a series of ramps with a total rise of more than 600 mm should have a continuous handrail
- guarding to resist a horizontal force of 0.74kN/m.

**Level Access:**

- See A(02.11)03 for existing threshold.
- See A(02.11)19 for new threshold.

Proprietary MS galvanised diamond pattern woven mesh netting fixed to handrail & uprights L31.222

Brush texture finish E41.340

Min. 125 mm thk concrete ramp E10.140

50 mm blinding D20.730

Crushed rock 600 mm max. depth D20.720

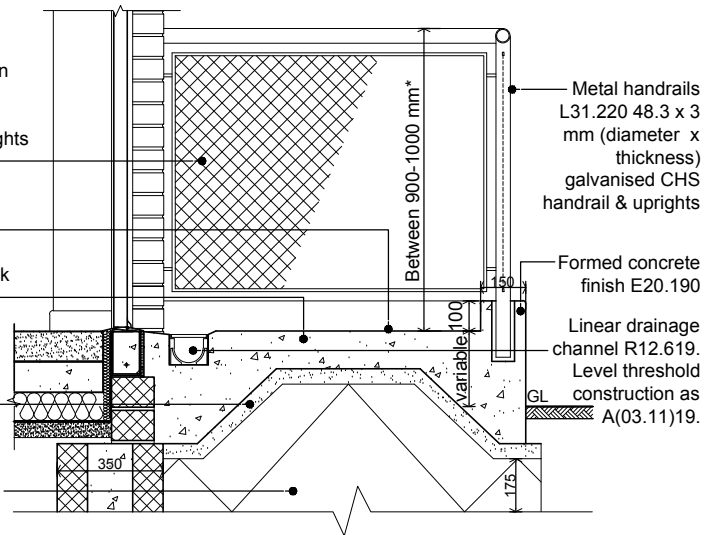

\* Could be used for existing and proposed builds.  
\* To be confirmed by Occupational Therapist.

© NIHE 2017 DRAWINGS NOT TO BE SCALED DUE TO PRINTING DISTORTION

**Housing Executive**

**BCNI Standards Panel Agreed \***



TITLE	RAMP ACCESS TO DWELLINGS (PARALLEL ENTRY)		
-------	---	--	--

DRAWN BY	P&S	SCALE	1:25	DATE	Apr 91
DRAWING NO.	A(08.11)03				
REV NO. & DATE	(6) 02/15				
REV NOTE:	Updated to Revised Spec & APD Toolkit				

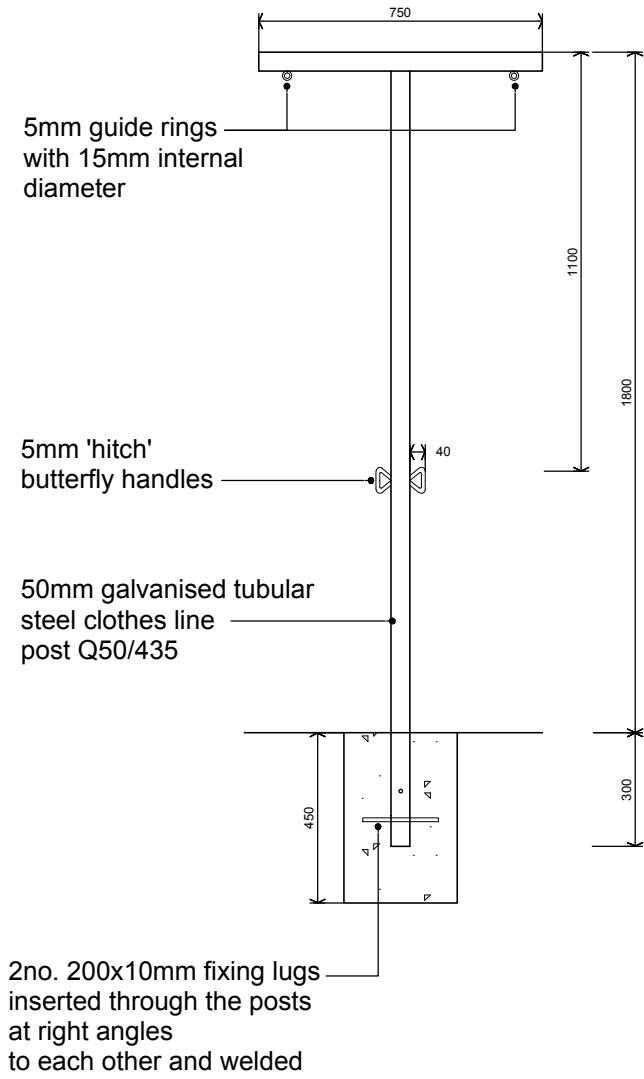



Note: Complete unit to be galvanised as Z11/360 after manufacture

	TITLE	DRAWN BY	SCALE	DATE
	<b>GALVANISED TUBULAR                  STEEL CLOTHES LINE                  POST</b>	TJB/CB	1:20	Feb 98
		DRAWING NO.	A(08.11)04	
		REV NO. & DATE	(1) 10/12	
REV NOTE:		Updated to revised spec		

\* This NIHE produced detail has been examined by The Building Control N.I. Standards Panel and has been considered reasonable in its interpretation of the relevant requirements of the Building Regulation NI 2012. There is no legal obligation for any Building Control department to adopt this recommendation & it is subject to revision in the event of changes to the legislation or other mitigating circumstances.

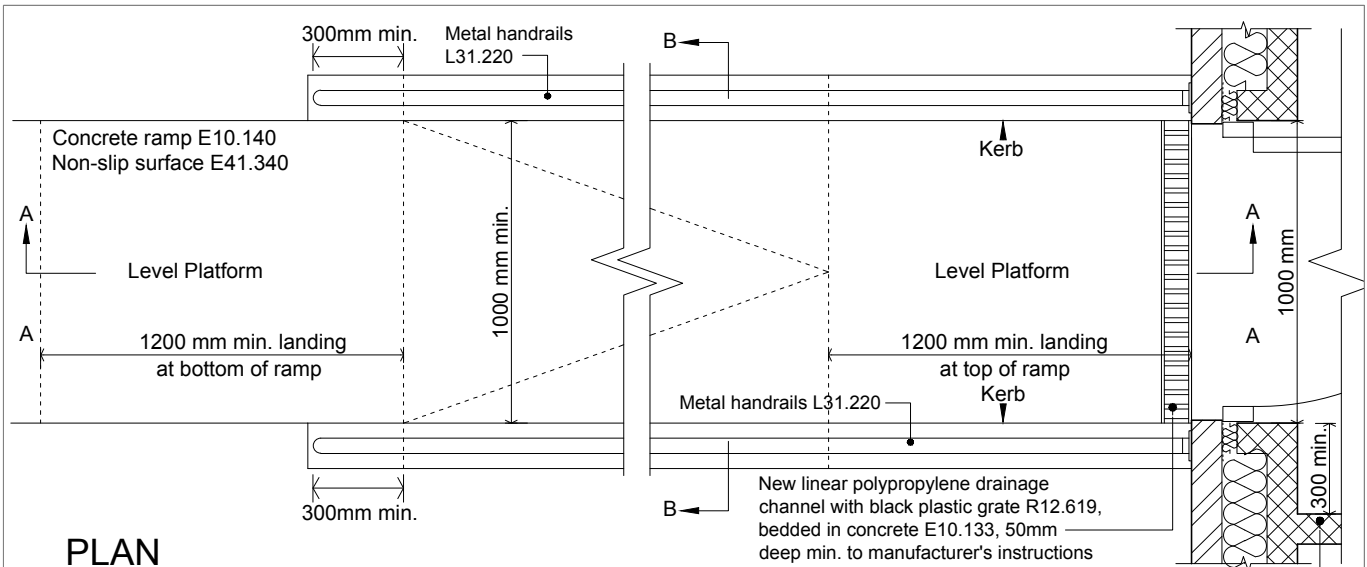

**PLAN**

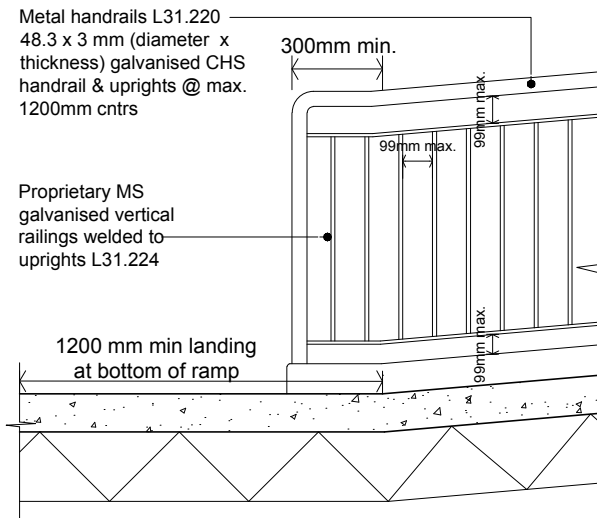

**SECTION A:A**

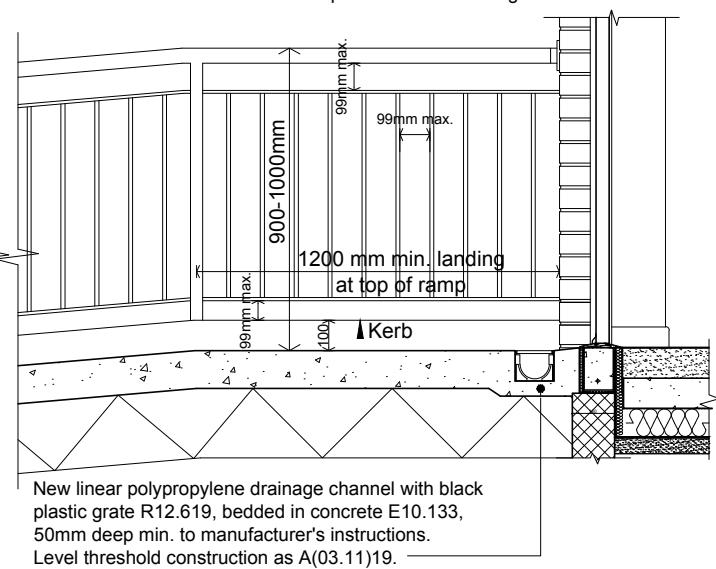

**NOTES:**

Ramps, handrails etc. to comply with current Building Regulations, Technical Booklet H.

**Ramps:**

- Gradient no steeper than 1:12.
- Cross-fall no greater than 1:40.
- The length of a ramp measured on plan, may not exceed 10m long at 1:15 or 5m long at 1:12.
- If the above lengths cannot be achieved, a resting platform of at least 1500 mm long must be provided.

**Handrails:**

- 48.3mm galvanised circular hollow sections.
- Must terminate in a closed end.
- Must be continuous for length of the ramp.
- Should be securely fixed in accordance with manufacturer's instructions.
- A ramp or a series of ramps with a total rise of more than 600 mm should have a continuous handrail guarding to resist a horizontal force of 0.74kN/m.

**Level Access:**

- See A(02.11)03 for existing threshold.
- See A(02.11)19 for new threshold.

\* To be confirmed by Occupational Therapist.

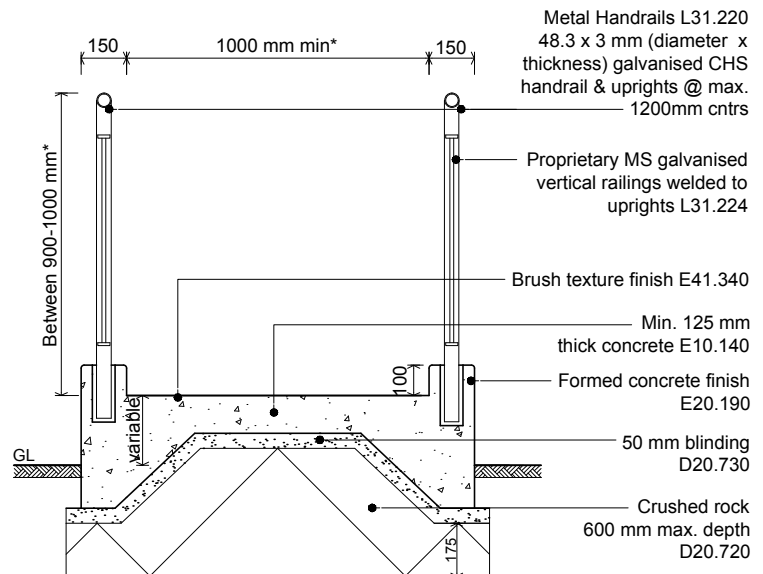

**SECTION B:B (1:25)**

TITLE	HANDRAIL & BALUSTRADE		
	vertical railings		

DRAWN BY	P&S	SCALE	1:25	DATE	NOV '16
DRAWING NO.	A(08.11)05				
REV NO. & DATE					
REV NOTE:					



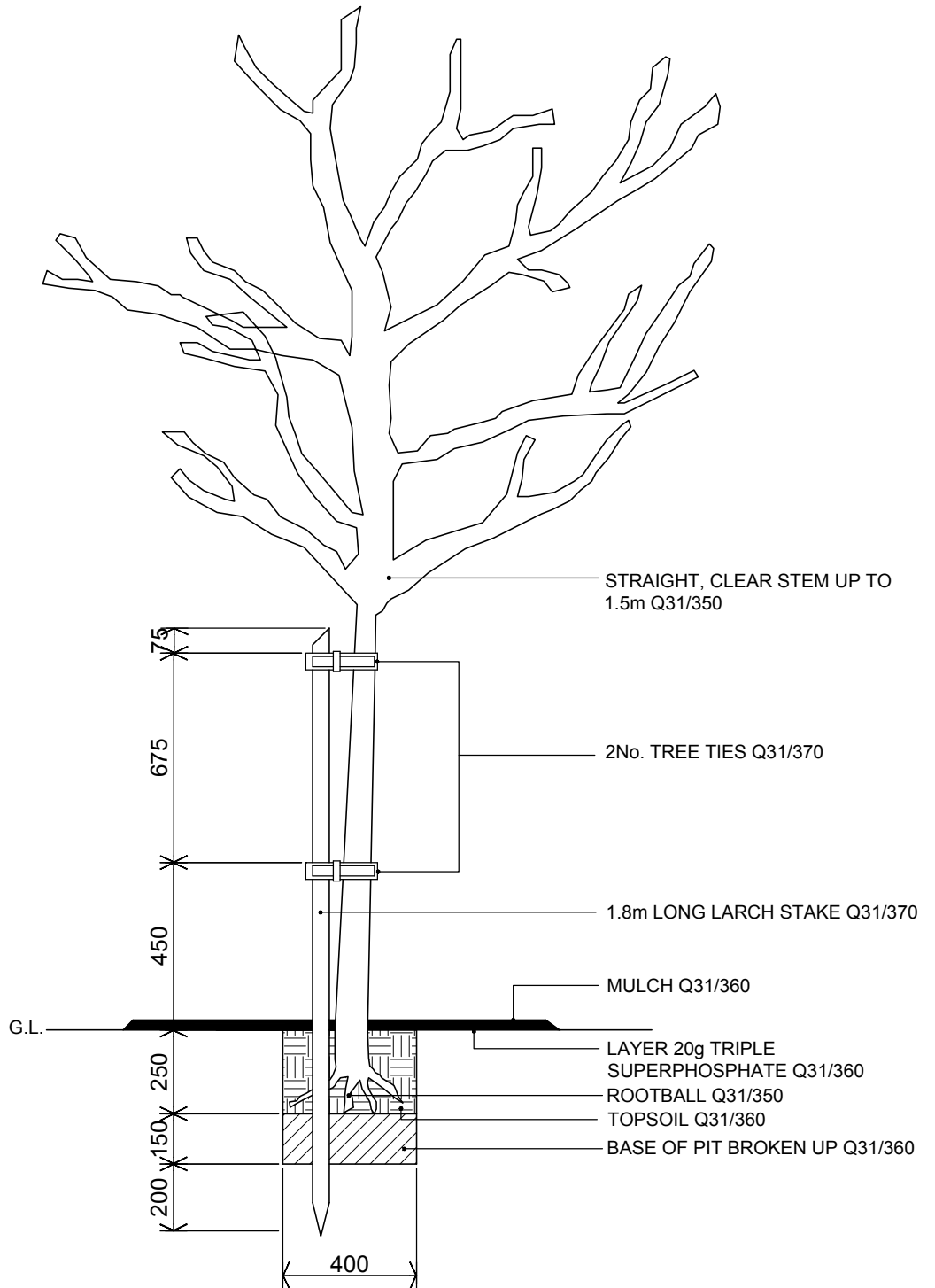

SPECIFICATION REF. Q31/600,605 FOR ESTABLISHMENT AND MAINTAINANCE



TITLE  
**TREE PLANTING**  
 Tree with girth less than 100mm

DRAWN BY <b>TJB/CB</b>	SCALE <b>N.T.S.</b>	DATE <b>Sept 00</b>
DRAWING NO.	<b>A(08.12)01</b>	
REV NO. & DATE	<b>(1) 10/12</b>	
REV NOTE: <b>Updated to revised spec</b>		

© NIHE 2015  
DRAWINGS NOT TO BE SCALED DUE TO PRINTING DISTORTION

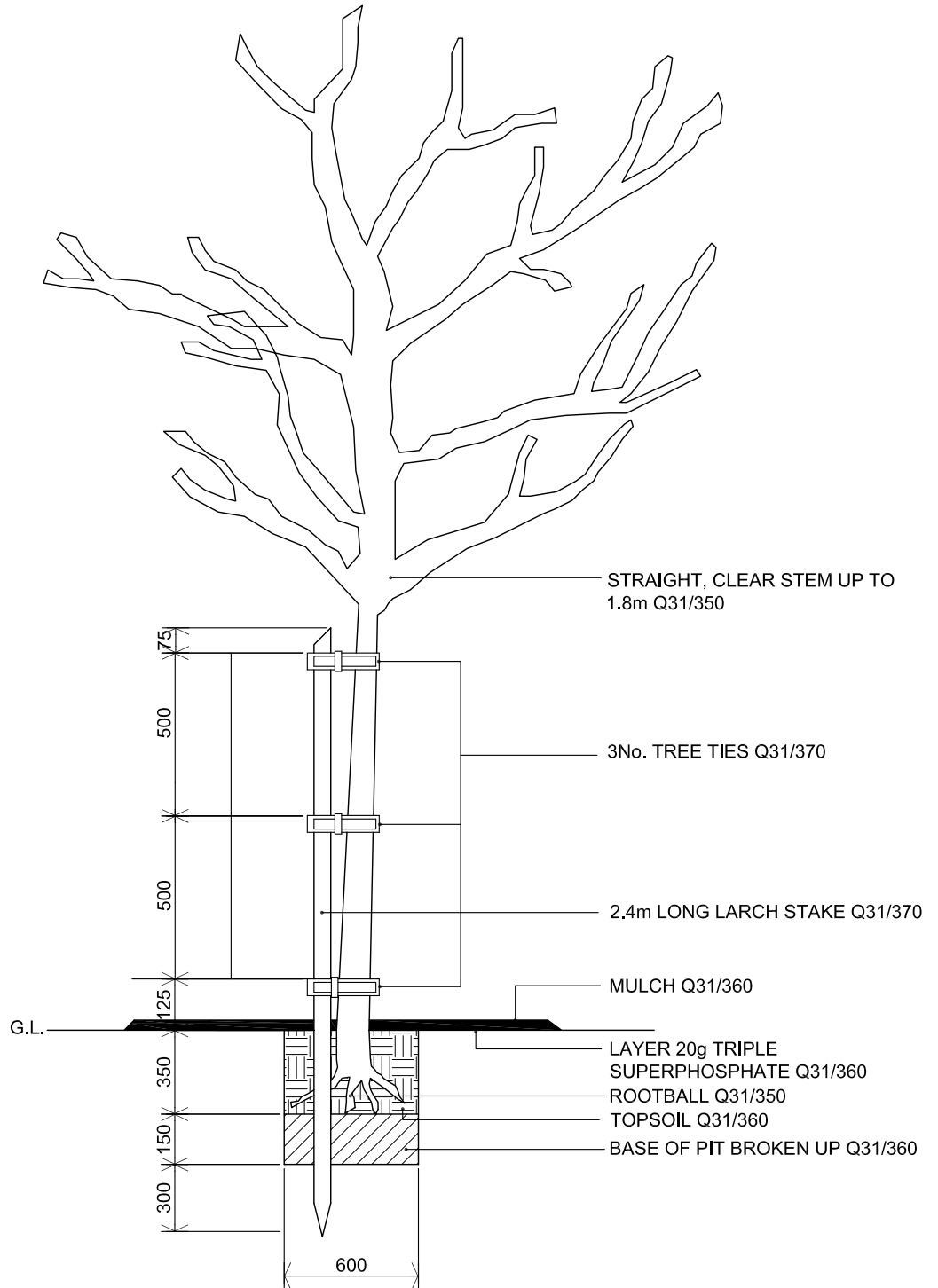

SPECIFICATION REF. Q31/600,605 FOR ESTABLISHMENT AND MAINTAINANCE



TITLE  
**TREE PLANTING**  
 Tree with girth between  
 100-140mm

DRAWN BY <b>TJB/CB</b>	SCALE <b>N.T.S.</b>	DATE <b>Sept 00</b>
DRAWING NO.	<b>A(08.12)02</b>	
REV NO. & DATE	<b>(1) 10/12</b>	
REV NOTE: <b>Updated to revised spec</b>		

© NIHE 2015  
DRAWINGS NOT TO BE SCALED DUE TO PRINTING DISTORTION

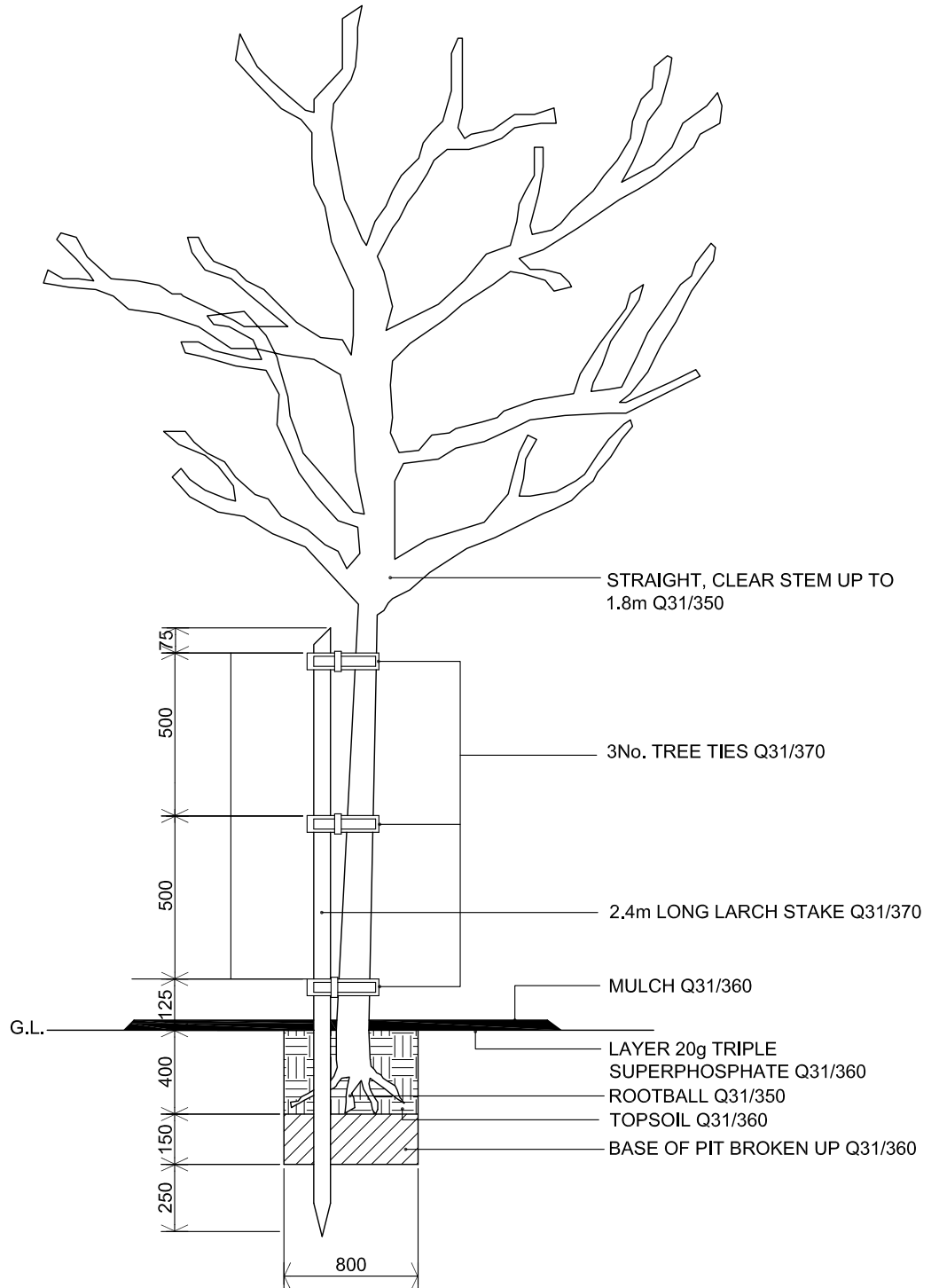

SPECIFICATION REF. Q31/600,605 FOR ESTABLISHMENT AND MAINTAINANCE



TITLE  
**TREE PLANTING**  
Tree with girth  
above 140mm

DRAWN BY <b>TJB/CB</b>	SCALE <b>N.T.S.</b>	DATE <b>Sept 00</b>
DRAWING NO.	<b>A(08.12)03</b>	
REV NO. & DATE	<b>(1) 10/12</b>	
REV NOTE: <b>Updated to revised spec</b>		



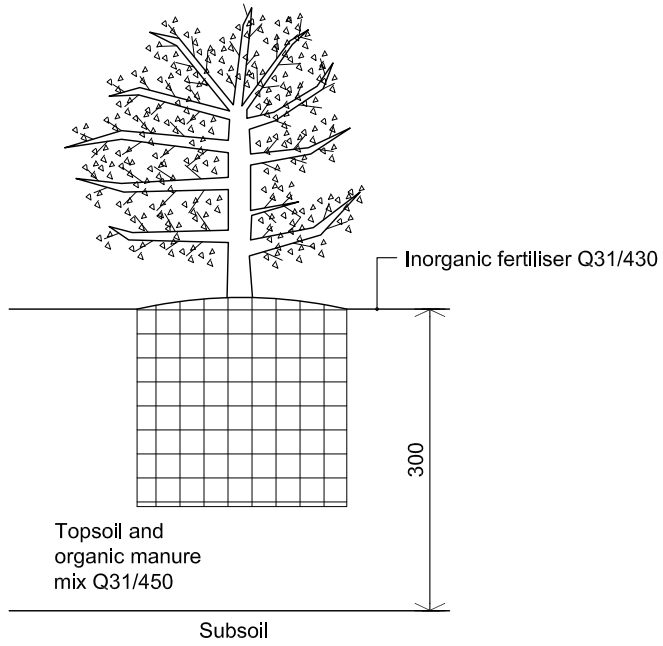

CONTAINERIZED SHRUBS Q31/510

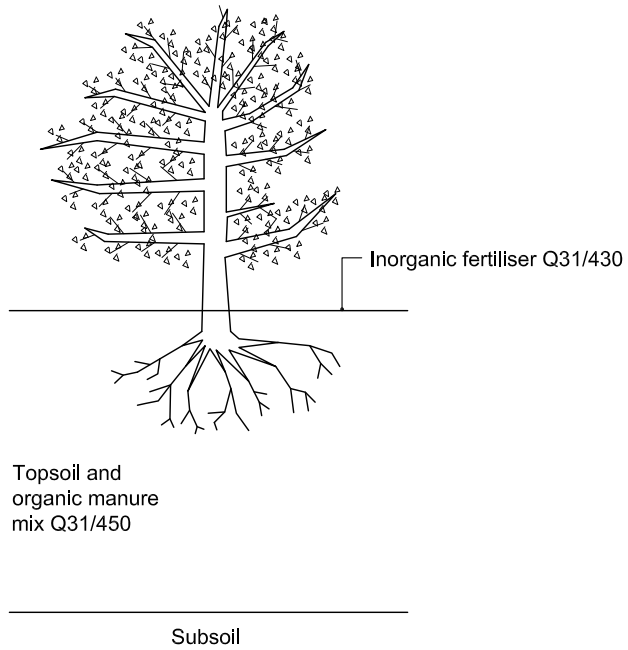

BARE-ROOT SHRUBS AND WHIP Q31/510

FOR PLANTING METHOD SPECIFICATION  
REF.Q31/400,540

FOR ESTABLISHMENT AND MAINTAINANCE  
SPECIFICATION REF.Q31/585,600,603,605

© NIHE 2015  
DRAWINGS NOT TO BE SCALED DUE TO PRINTING DISTORTION



TITLE  <b>SHRUB AND WHIP PLANTING</b>	DRAWN BY <b>TJB</b>	SCALE <b>N.T.S.</b>	DATE <b>Sept 00</b>
	DRAWING NO. <b>A(08.12)04</b>		
	REV NO. & DATE		
	REV NOTE:		



© NIHE 2015  
DRAWINGS NOT TO BE SCALED DUE TO PRINTING DISTORTION

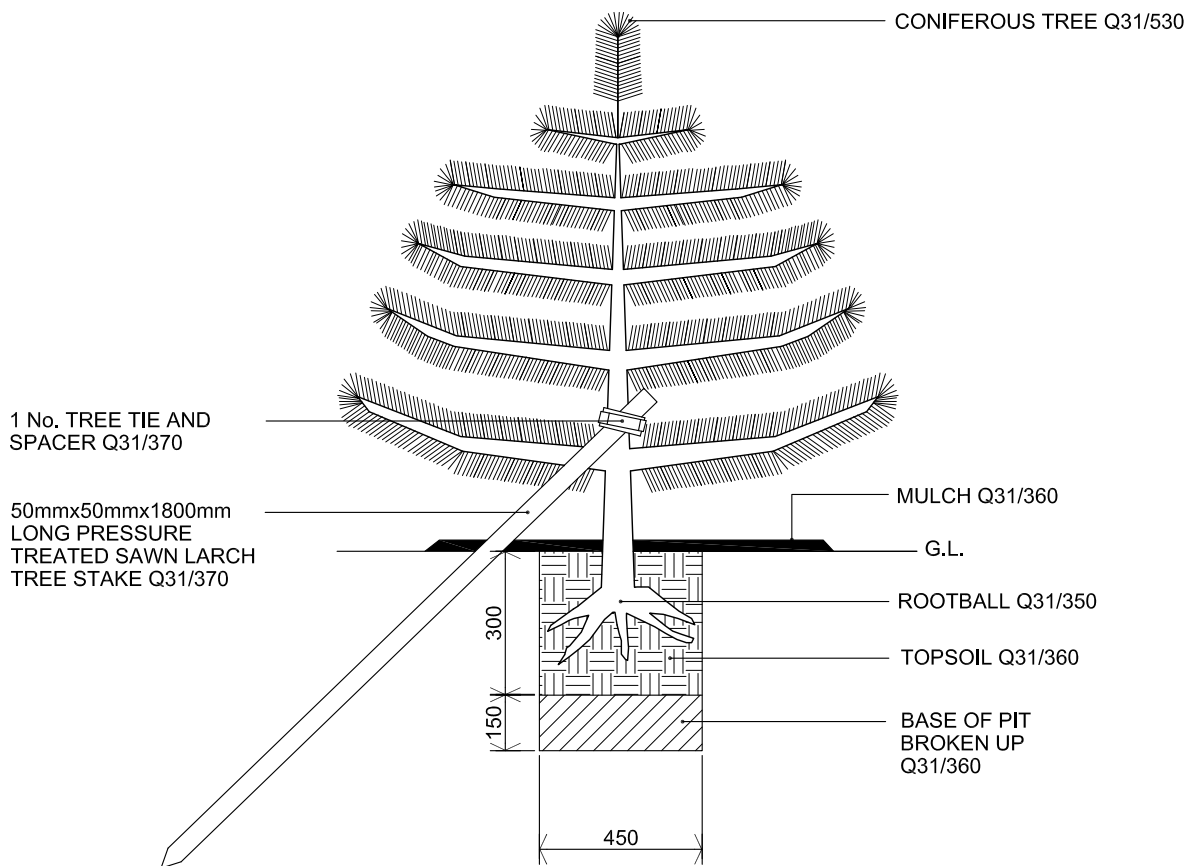

SPECIFICATION REF. Q31/400,540  
FOR METHOD OF PLANTING  
FOR ESTABLISHMENT AND MAINTAINANCE  
SPECIFICATION REF. Q31/600,604,605,607



TITLE <b>TREE PLANTING</b> Conifers	DRAWN BY <b>TJB/CB</b>	SCALE <b>N.T.S.</b>	DATE <b>Sept 00</b>
	DRAWING NO. <b>A(08.12)05</b>		
	REV NO. & DATE <b>(1) 10/12</b>		
	REV NOTE: <b>Updated to revised spec</b>		



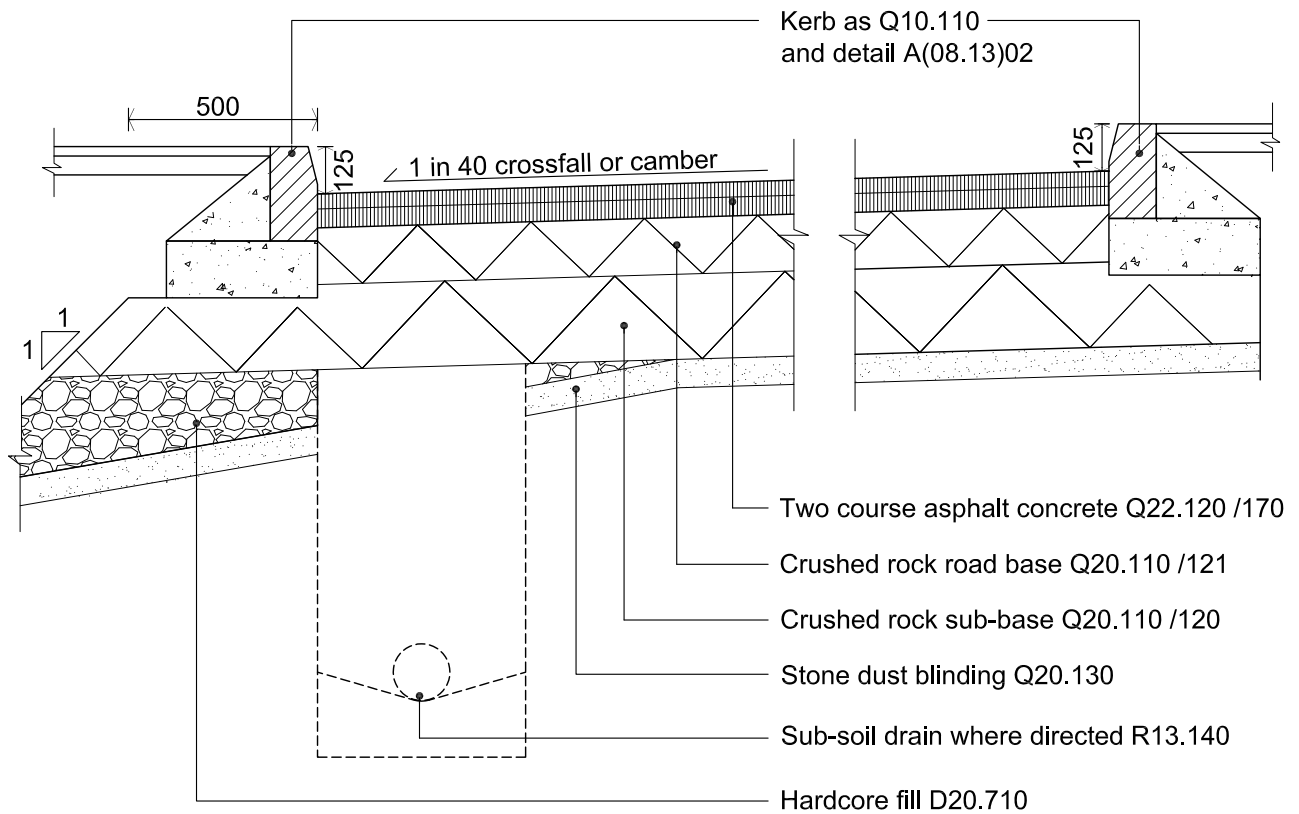

FLEXIBLE CARRIAGEWAY - MINIMUM CONSTRUCTION DEPTHS (mm)			
		CARRIAGEWAY WIDTH	
		6.0m or less	exceeding 6.0m
SURFACE COURSE	As Q22.120/170	40	40
BINDER COURSE	As Q22.120/170	60	60
CRUSHED ROCK ROAD BASE		150	225
CRUSHED ROCK SUB-BASE		225	250
STONE DUST BLINDING LAYER		75	75

**NOTES:**

- Carriageway width in relation to an irregularly shaped area in a cul-de-sac shall be defined as being the minimum clear distance between edge restraints of the access to the area.
- Where a coloured finish is desired chippings may be applied to asphalt as Q22.316.
- Depths shown are the minimum requirement and may need to be increased in poor ground conditions. Verification should be sought from the Civil Engineer.



TITLE  <b>FLEXIBLE CARRIAGEWAY</b>  Typical cross section	DRAWN BY <b>P&amp;S</b>	SCALE <b>1:20</b>	DATE <b>Mar 91</b>
	DRAWING NO.	<b>A(08.13)01</b>	
	REV NO. & DATE	<b>(3) 06/14</b>	
	REV NOTE:	<b>Updated to Roads Service Details</b>	



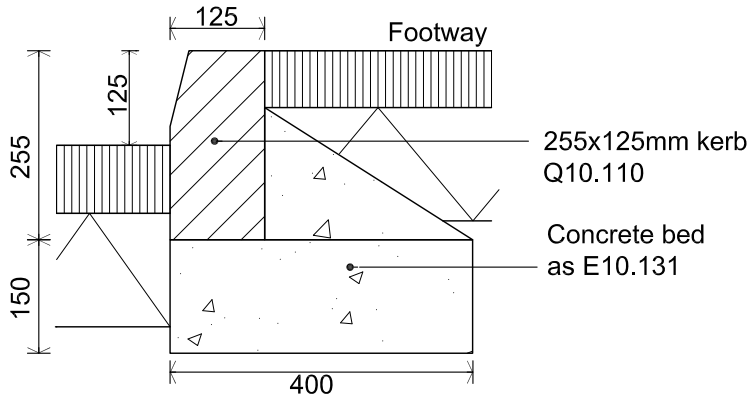

UPRIGHT SETTING A

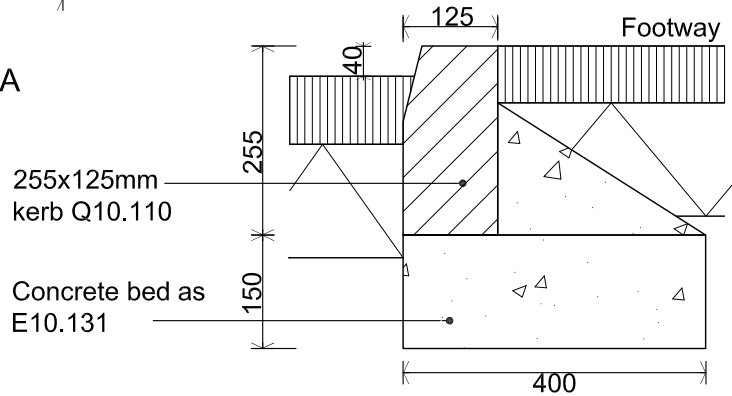

UPRIGHT SETTING B

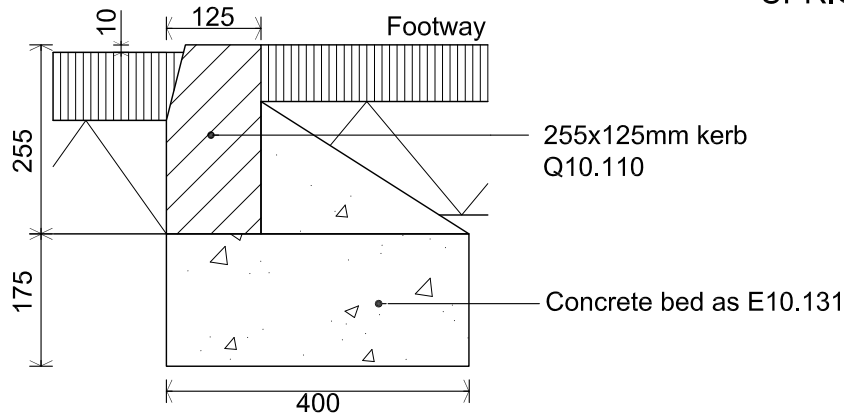

UPRIGHT SETTING C

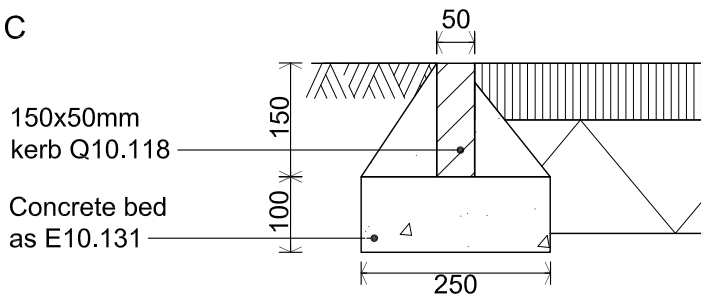

EDGING KERB

NOTE : All concrete for kerb bases and haunches to be mix E10.131

© NIHE 2015  
DRAWINGS NOT TO BE SCALED DUE TO PRINTING DISTORTION



<b>TYPICAL KERB SETTINGS</b>	TITLE		DRAWN BY <b>P&amp;S</b>	SCALE <b>1:10</b>	DATE <b>Mar 91</b>
			DRAWING NO. <b>A(08.13)02</b>		
			REV NO. & DATE <b>3 (06/14)</b>		
			REV NOTE: <b>Updated to revised spec</b>		



© NIHE 2015  
 DRAWINGS NOT TO BE SCALED DUE TO PRINTING DISTORTION

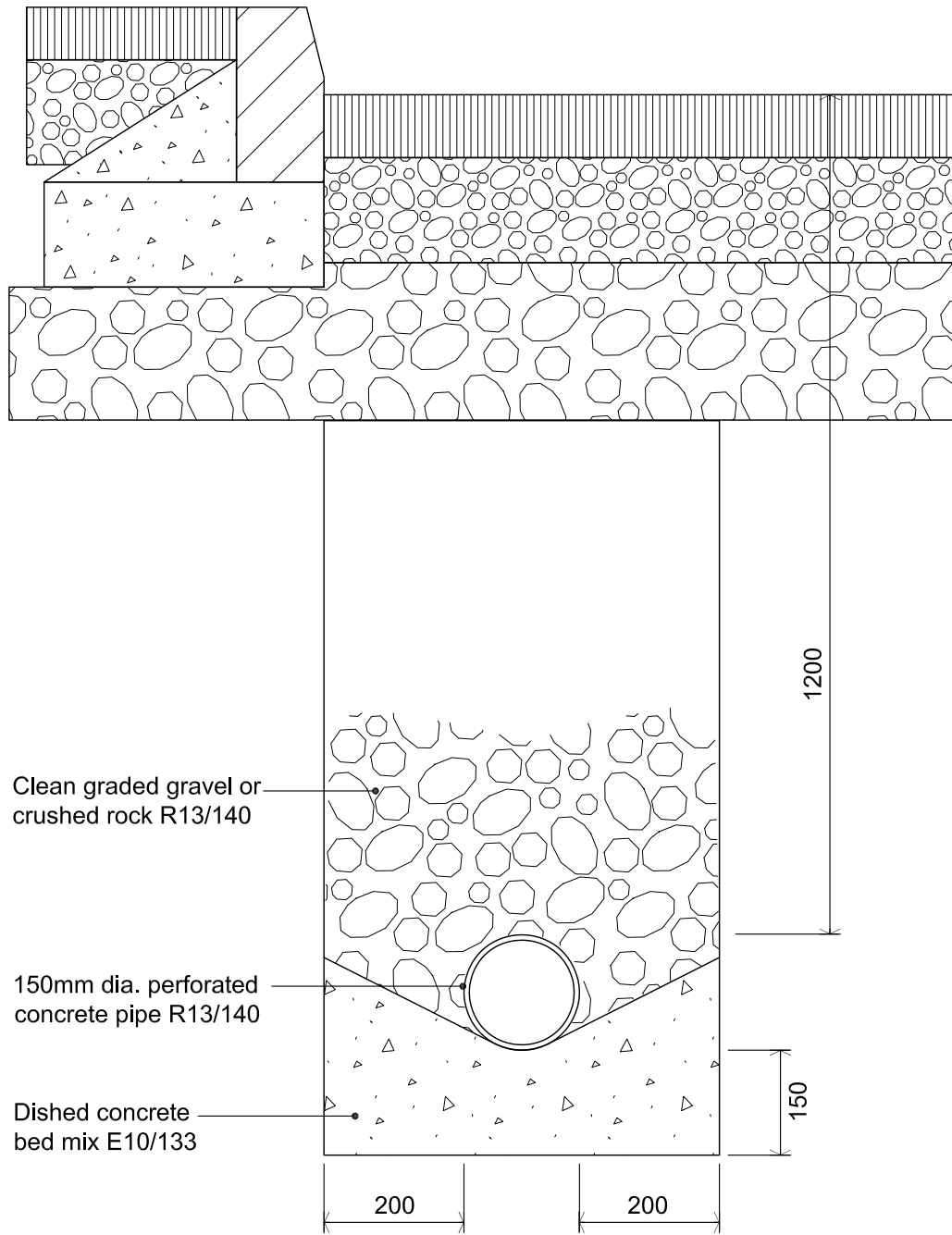

SUB-BASE DRAIN



TITLE  SUB-BASE DRAIN DETAIL	DRAWN BY L.M.	SCALE 1:10	DATE Mar 91
	DRAWING NO.	A(08.13)03	
	REV NO. & DATE	3 (3/04)	
	REV NOTE:		



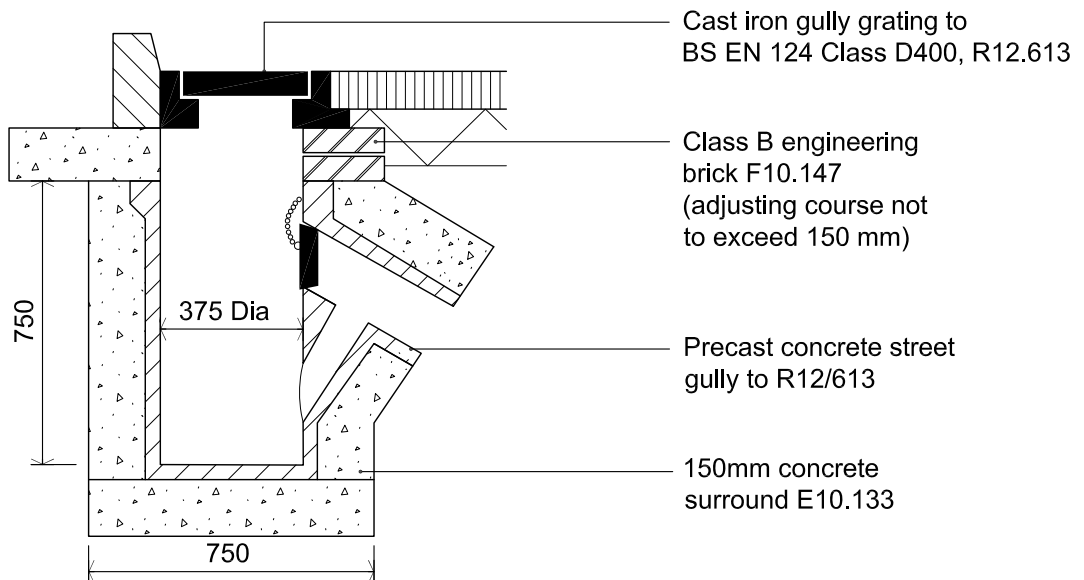

**TRAPPED GULLY**  
(for use with combined systems only)

Cast iron gully  
300x230x280mm deep hinged  
and channelled with 100mm dia  
outlet and rodding eye R12/612

100mm concrete surround

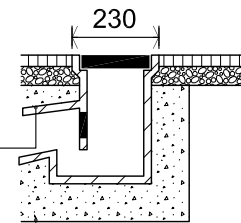

**FOOTWAY GULLY**

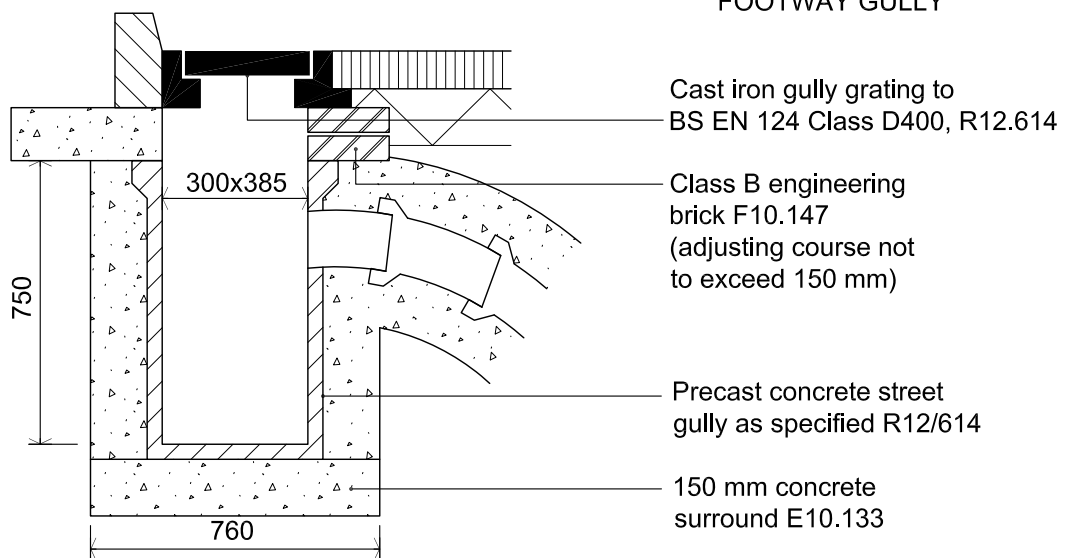

**UNTRAPPED GULLY**  
(for use with storm water systems only)

**NOTE:**

- All concrete for use in beds and haunches to gullies shall be mix E10.133
- Gullies must be capable of being easily rodded.
- Any gaps between pot and outlet pipe or grating and adjacent kerb to be filled with mortar.



<b>TITLE</b>  <b>GULLY DETAILS</b>	<b>DRAWN BY</b> P&S	<b>SCALE</b> 1:20	<b>DATE</b> Dec 90
	<b>DRAWING NO.</b> A(08.13)04		
	<b>REV NO. &amp; DATE</b> (5) 07/14		
	<b>REV NOTE:</b> Updated to Roads Service Details		

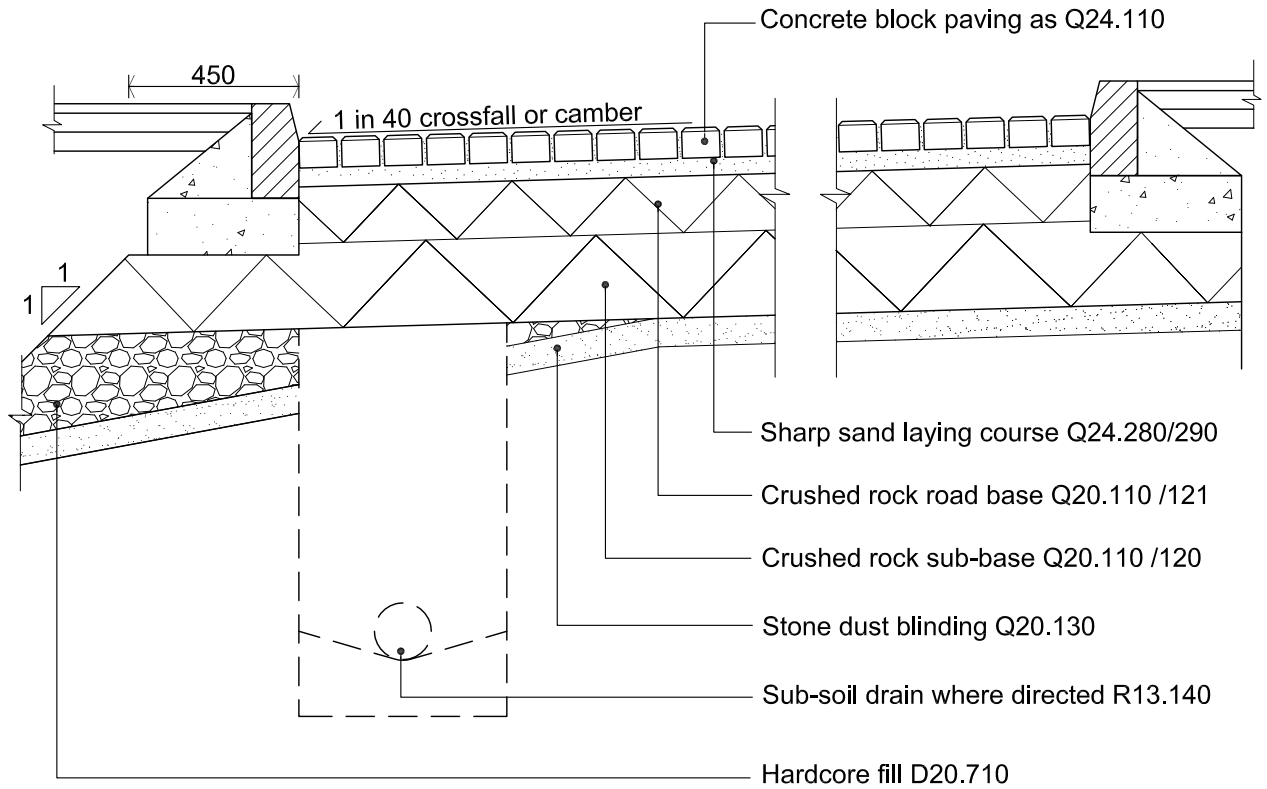

**PAVING BLOCK CARRIAGEWAY - MINIMUM CONSTRUCTION DEPTHS (mm)**

	CARRIAGEWAY WIDTH	
	6.0m or less	exceeding 6.0m
CONCRETE PAVING BLOCK	80	80
SAND LAYING COURSE	50	50
CRUSHED ROCK ROAD BASE	150	225
CRUSHED ROCK SUB-BASE	225	250
STONE DUST BLINDING LAYER	75	75

**NOTES:**

- Carriageway width in relation to an irregularly shaped area in a cul-de-sac shall be defined as being the minimum clear distance between edge restraints of the access to the area.
- Depths shown are the minimum requirement and may need to be increased in poor ground conditions. Verification should be sought from the Civil Engineer.

© NIHE 2015 DRAWINGS NOT TO BE SCALED DUE TO PRINTING DISTORTION



<b>TITLE</b>  <b>CONCRETE PAVOIR CARRIAGEWAY</b>  typical cross section	<b>DRAWN BY</b> P&S	<b>SCALE</b> 1:20	<b>DATE</b> Mar 91
	<b>DRAWING NO.</b>	A(08.13)05	
	<b>REV NO. &amp; DATE</b>	(3) 04/14	
	<b>REV NOTE:</b> Updated to revised spec		

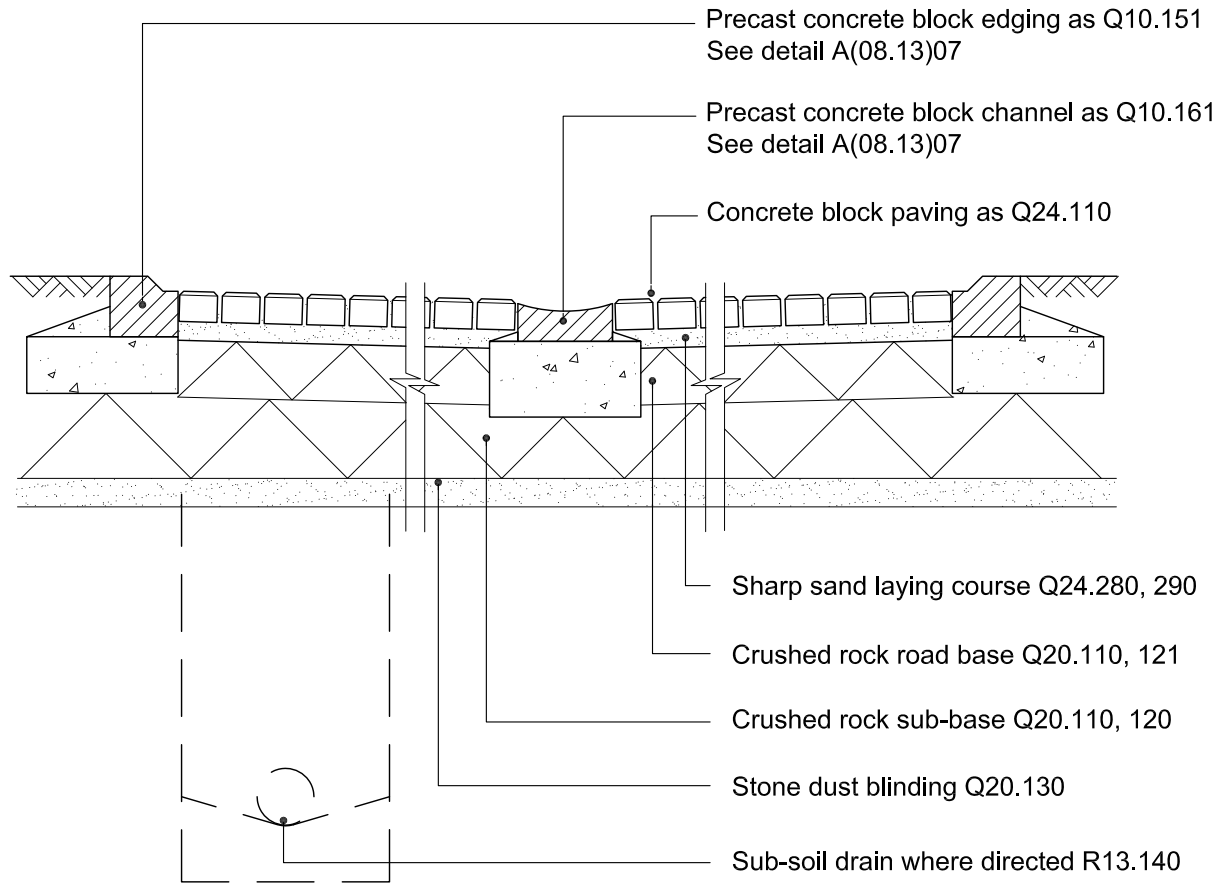

**PAVOIR SHARED SURFACE - MINIMUM CONSTRUCTION DEPTHS (mm)**

	CARRIAGEWAY WIDTH	
	6.0m or less	exceeding 6.0m
CONCRETE PAVING BLOCK	80	80
SAND LAYING COURSE	50	50
CRUSHED ROCK ROAD BASE	150	225
CRUSHED ROCK SUB-BASE	225	250
STONE DUST BLINDING LAYER	75	75

**NOTES:**

- Carriageway width in relation to an irregularly shaped area in a cul-de-sac shall be defined as being the minimum clear distance between edge restraints of the access to the area.
- Depths shown are the minimum requirement and may need to be increased in poor ground conditions. Verification should be sought from the Civil Engineer.

© NIHE 2015  
DRAWINGS NOT TO BE SCALED DUE TO PRINTING DISTORTION



<b>TITLE</b> CONCRETE PAVOIR SHARED SURFACE typical cross section	<b>DRAWN BY</b> P&S	<b>SCALE</b> 1:20	<b>DATE</b> Mar 91
	<b>DRAWING NO.</b> A(08.13)06		
	<b>REV NO. &amp; DATE</b> (3) 06/14		
	<b>REV NOTE:</b> Updated to revised spec		



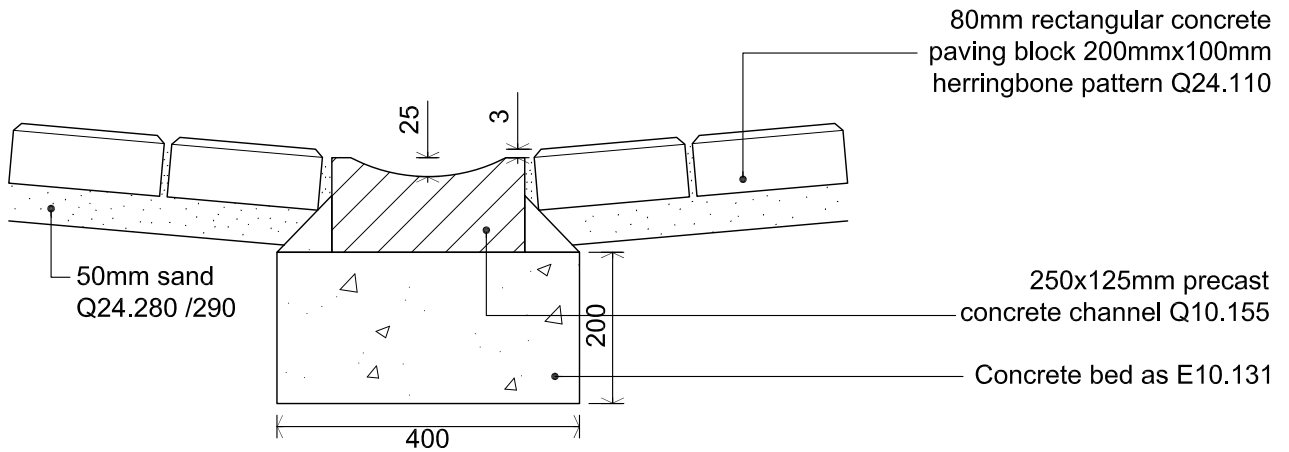

**CONCRETE CHANNEL BLOCK**

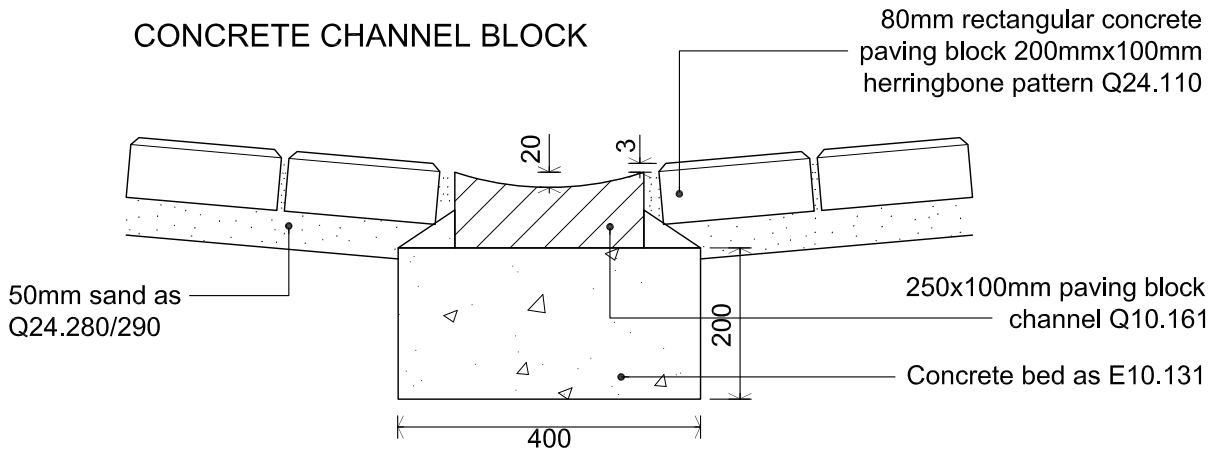

**PAVING BLOCK CHANNEL**

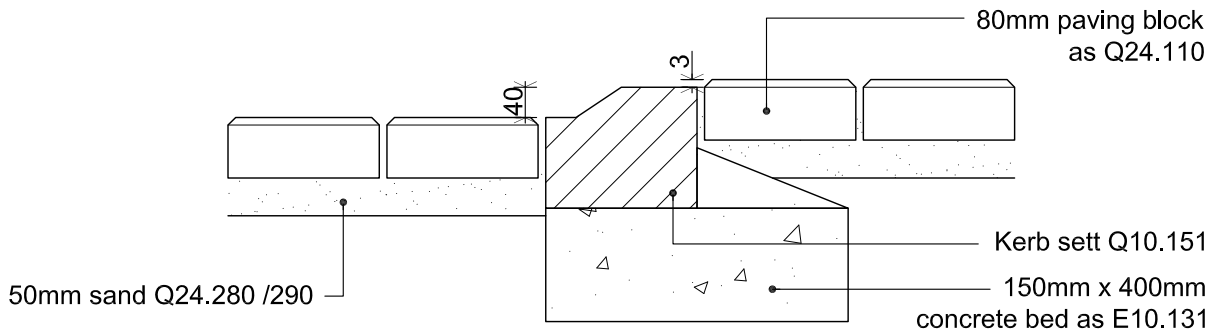

**KERB SETT DETAIL**

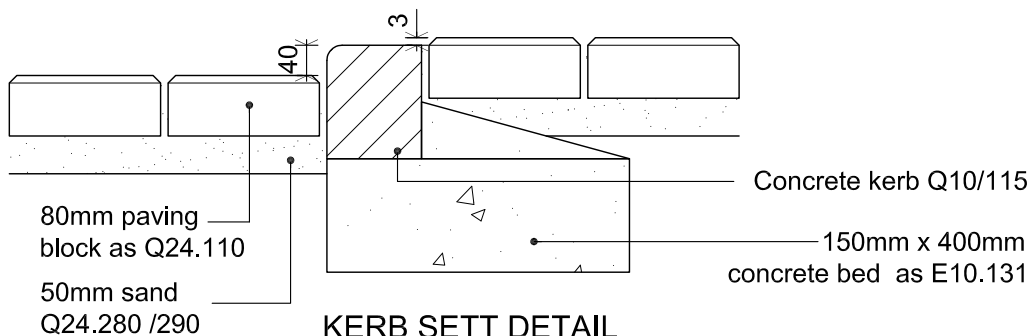

**KERB SETT DETAIL**

NOTE : All bedding concrete and haunching shall be mix E10.131

© NIHE 2015 DRAWINGS NOT TO BE SCALED DUE TO PRINTING DISTORTION



TITLE <b>CENTRAL DRAINAGE CHANNEL AND KERB SETT DETAILS</b>	DRAWN BY <b>P&amp;S</b>	SCALE <b>1:10</b>	DATE <b>Dec 90</b>
	DRAWING NO. <b>A(08.13)07</b>		
	REV NO. & DATE <b>(4) 04/14</b>		
	REV NOTE: <b>Updated to revised spec</b>		



250x125mm dished P.C. concrete channel on concrete founds, laid to min. fall of 1/100 Q10.155

Dished cast iron heavy duty gully grating, set with hinge facing direction of traffic R12.615

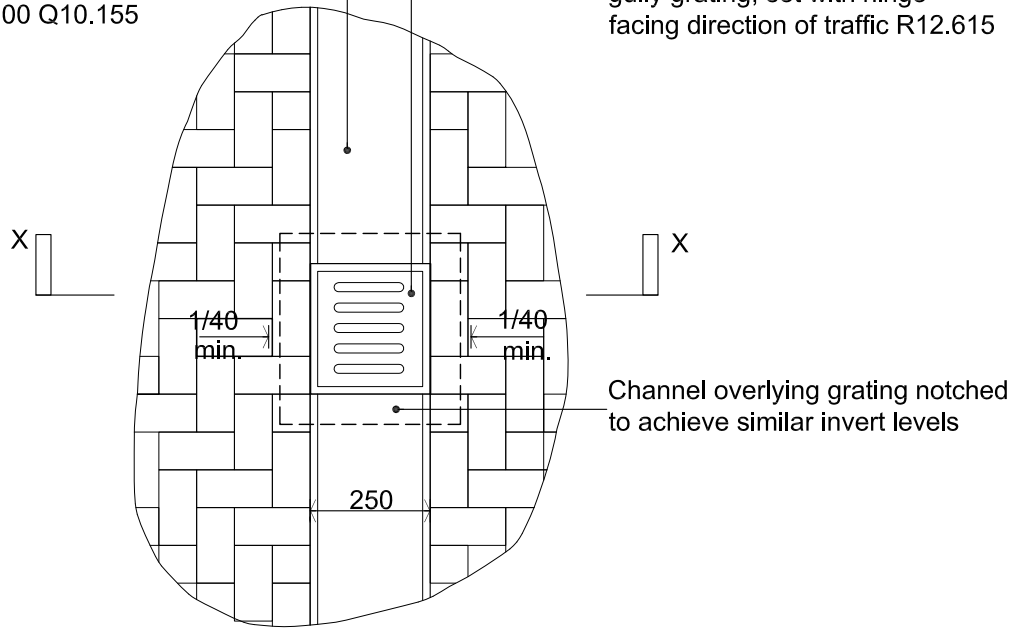

PLAN

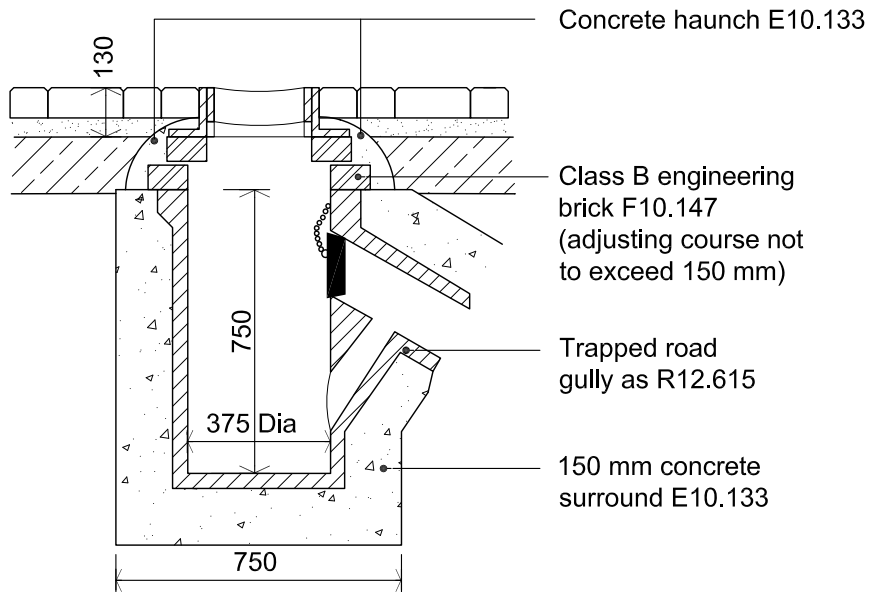

SECTION X-X

NOTE:

- All concrete for use in beds and haunches to gullies shall be mix E10.133
- Gullies must be capable of being easily rodded.

© NIHE 2015 DRAWINGS NOT TO BE SCALED DUE TO PRINTING DISTORTION



TITLE  
**PRECAST CONCRETE  
 BLOCK PAVEMENT  
 GULLY DETAILS**

DRAWN BY <b>P&amp;S</b>	SCALE <b>1:20</b>	DATE <b>Dec 90</b>
DRAWING NO.	<b>A(08.13)08</b>	
REV NO. & DATE	<b>(3) 06/14</b>	
REV NOTE:	<b>Updated to Roads Service details</b>	



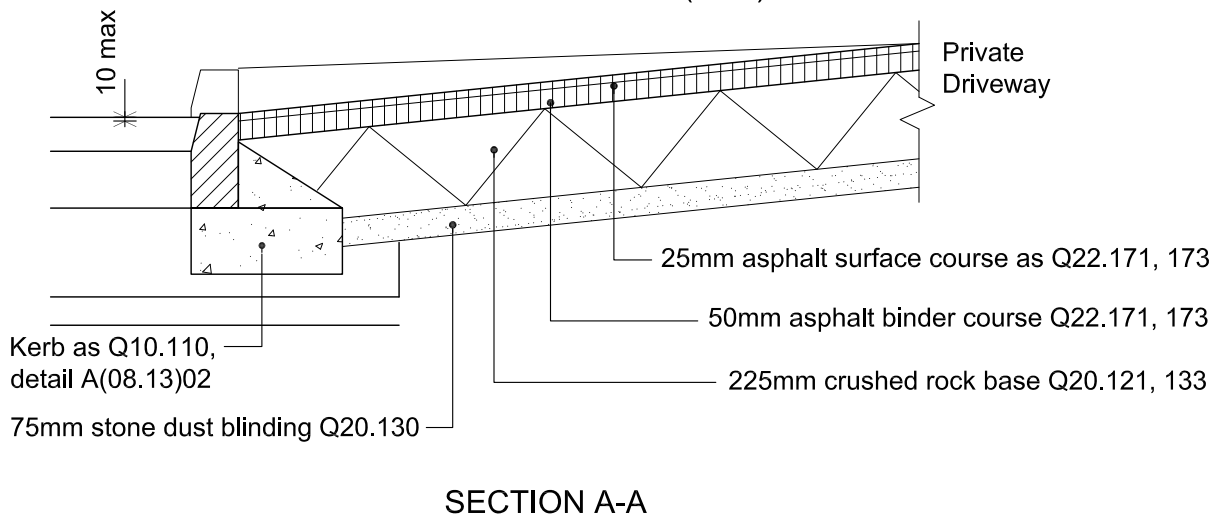
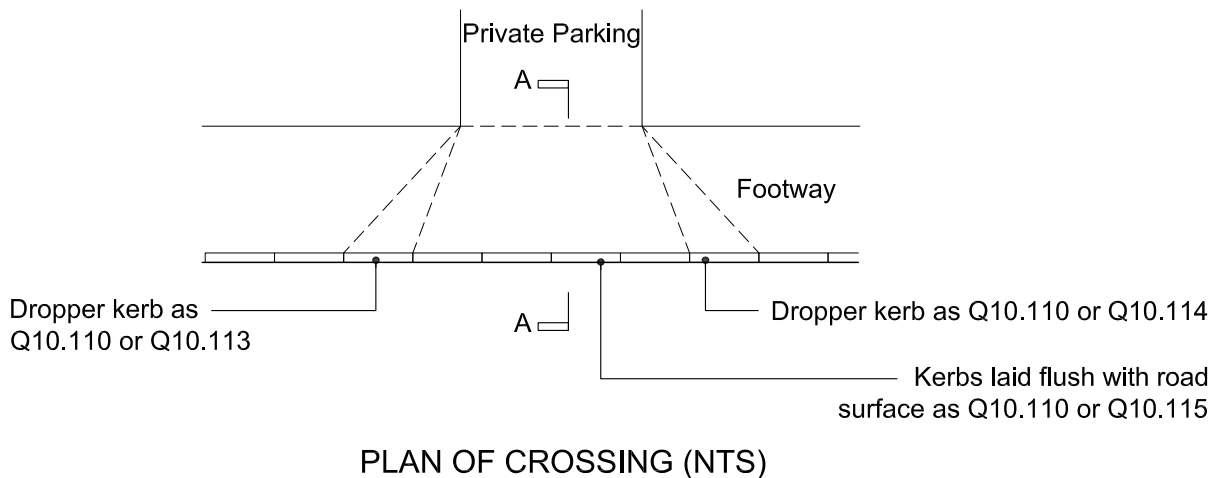
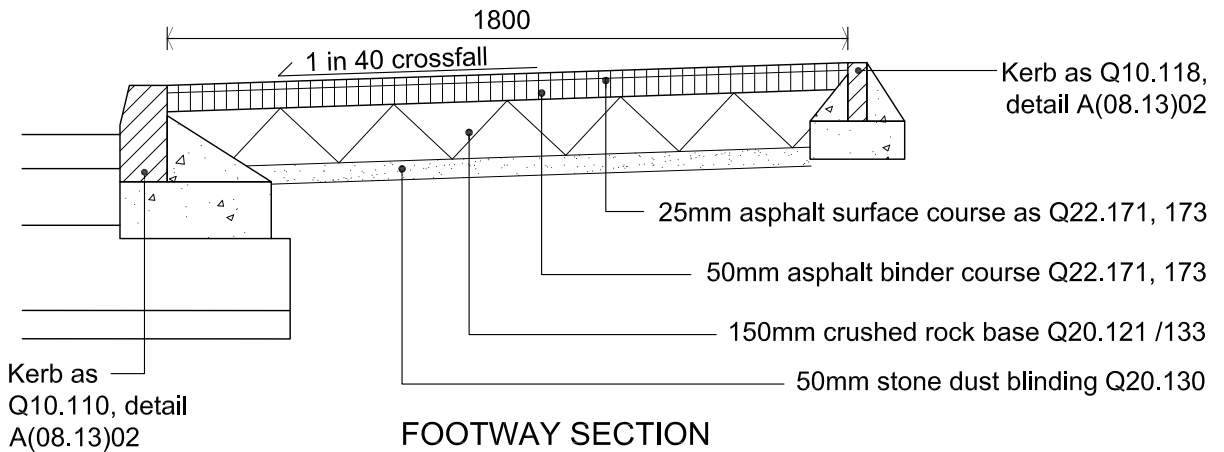

**NOTE:**

- Footway construction depths shown are the minimum requirement and may need to be increased in poor ground conditions. Verification should be sought from the Civil Engineer.
- Asphalt wearing course to be used on footways of all developments with access to a road with speed restricted to 30mph. 10mm gauge chippings as Q22.314 of a light colour shall be distributed at a rate of 1kg/m<sup>2</sup> and rolled into the surface.

© NIHE 2015  
DRAWINGS NOT TO BE SCALED DUE TO PRINTING DISTORTION



<b>TITLE</b>  FLEXIBLE FOOTWAY AND FOOTWAY CROSSING	DRAWN BY <b>P&amp;S</b>	SCALE <b>1:20</b>	DATE <b>Mar 91</b>
	DRAWING NO. <b>A(08.13)10</b>		
	REV NO. & DATE <b>(3) 06/14</b>		
	REV NOTE: <b>Updated to revised spec</b>		

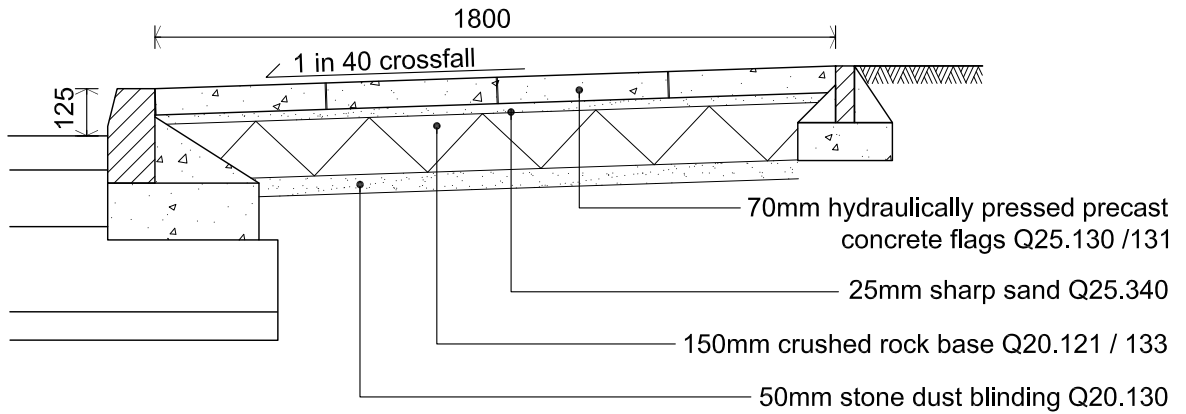

FOOTWAY SECTION

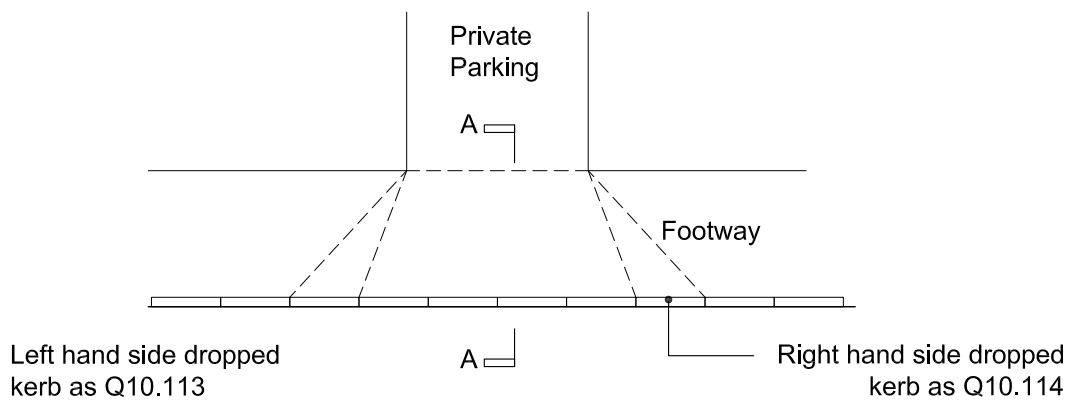

PLAN ON CROSSING (NTS)

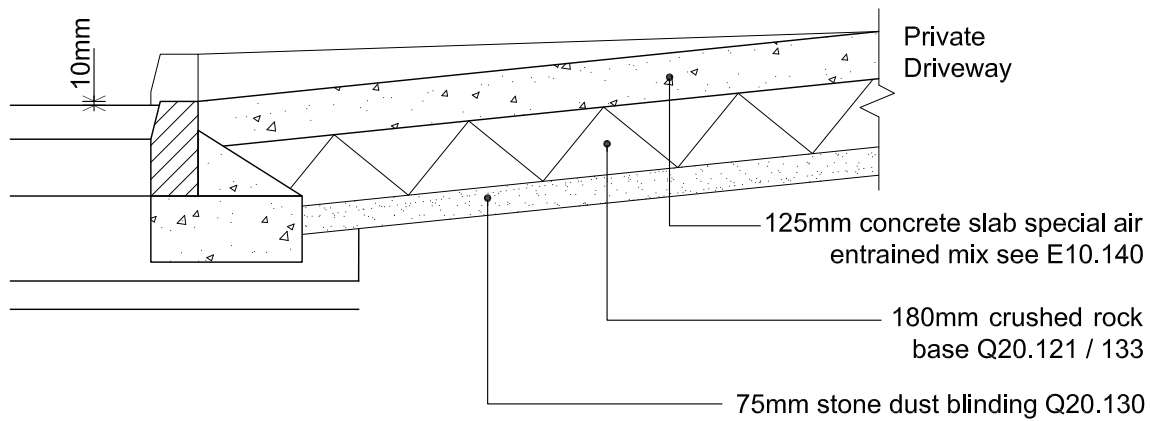

SECTION A-A

NOTE:

- Footway construction depths shown are the minimum requirement and may need to be increased in poor ground conditions. Verification should be sought from the Civil Engineer.

© NIHE 2015 DRAWINGS NOT TO BE SCALED DUE TO PRINTING DISTORTION



<b>TITLE</b>  FLAGGED FOOTWAY AND FOOTWAY CROSSING	<b>DRAWN BY</b> P&S	<b>SCALE</b> 1:20	<b>DATE</b> Mar 91
	<b>DRAWING NO.</b>	A(08.13)11	
	<b>REV NO. &amp; DATE</b>	(4) 05/14	
	<b>REV NOTE:</b> Updated to revised spec		

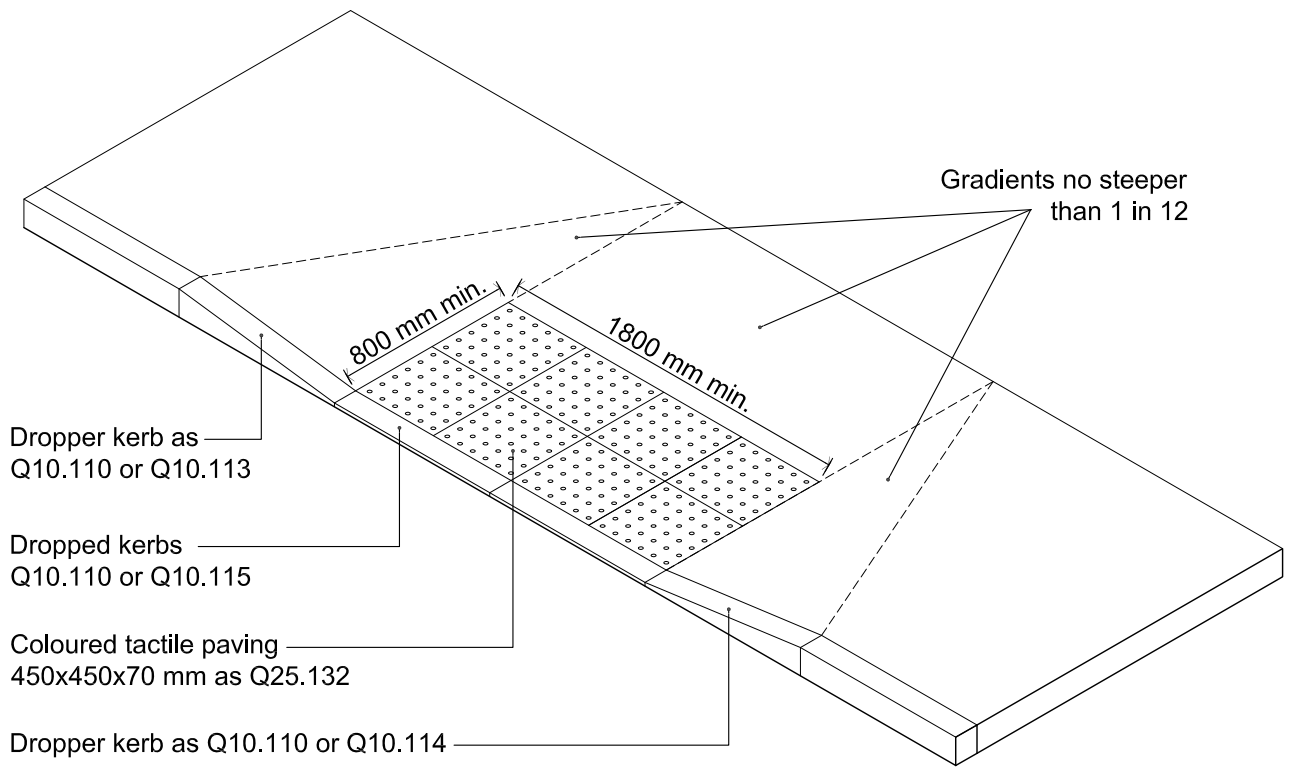

Dropper kerb as Q10.110 or Q10.113

Dropped kerbs Q10.110 or Q10.115

Coloured tactile paving 450x450x70 mm as Q25.132

Dropper kerb as Q10.110 or Q10.114

**WHEELCHAIR ACCESS (NTS)**

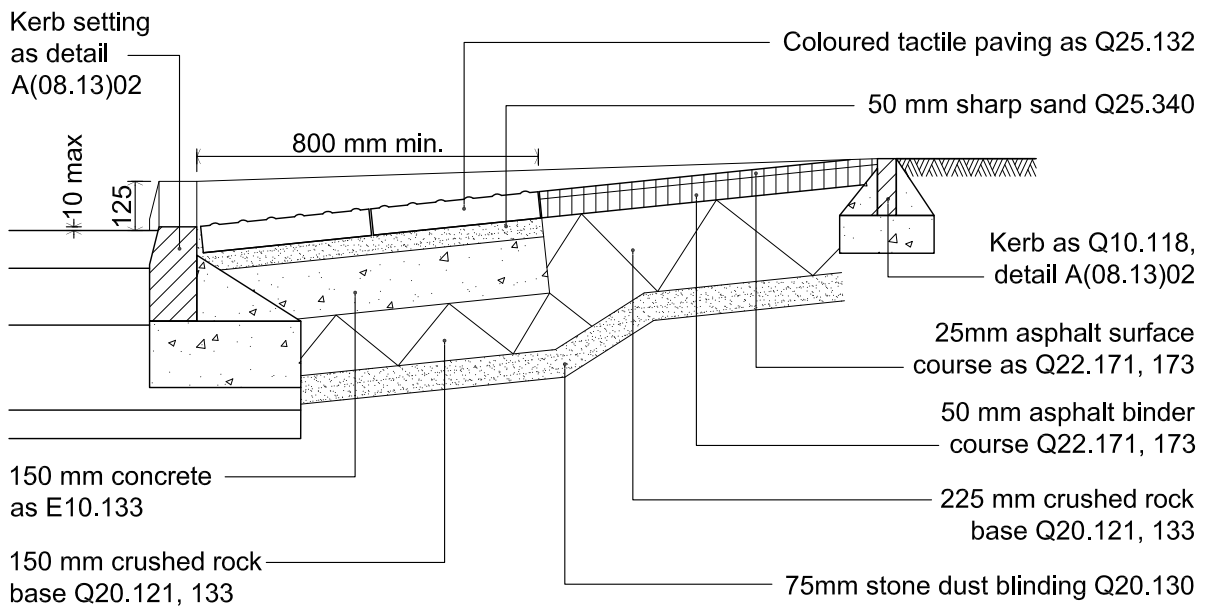

Kerb setting as detail A(08.13)02

Coloured tactile paving as Q25.132

50 mm sharp sand Q25.340

+/- 10 max

800 mm min.

Kerb as Q10.118, detail A(08.13)02

25mm asphalt surface course as Q22.171, 173

50 mm asphalt binder course Q22.171, 173

225 mm crushed rock base Q20.121, 133

150 mm concrete as E10.133

150 mm crushed rock base Q20.121, 133

75mm stone dust blinding Q20.130

**SECTION THROUGH ACCESSIBLE CROSSING (1:20)**

**NOTES:**

- Footway construction depths shown are the minimum requirement and may need to be increased in poor ground conditions. Verification should be sought from the Civil Engineer.
- Buff coloured tactile paving to be provided at uncontrolled pedestrian/wheelchair crossings at site entrances off local distributor roads.
- At junctions, the footway crossing shall be located behind the tangent point of the entry radius on the minor road and should enable crossing of the carriageway at right angles.

© NIHE 2015 DRAWINGS NOT TO BE SCALED DUE TO PRINTING DISTORTION



TITLE	WHEELCHAIR ACCESS AND FOOTWAY CROSSING		
-------	--	--	--

DRAWN BY P&S	SCALE 1:20	DATE Mar 91
DRAWING NO.	A(08.13)12	
REV NO. & DATE	(3) 05/14	
REV NOTE: Updated to Roads Service Details		

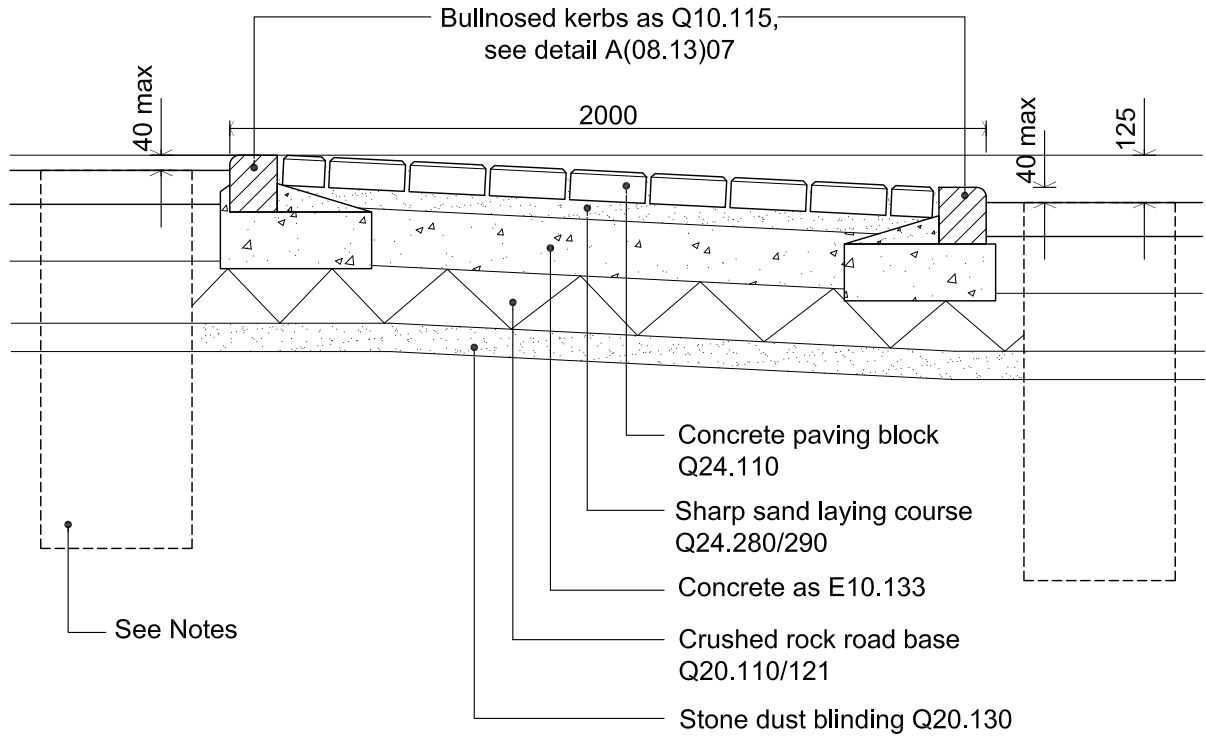

RUMBLE STRIP - MINIMUM CONSTRUCTION DEPTHS (mm)	
CONCRETE PAVING BLOCK	80
SAND LAYING COURSE	50
CONCRETE	150
CRUSHED ROCK ROAD BASE	150
STONE DUST BLINDING LAYER	75

**NOTES:**

- Gullies shall be sited on each side of carriageway or shared surface on the upper side of and immediately adjacent to the rumble strip.
- Where the shared surface is to be surfaced using paving blocks the row of kerbs at the back of the rumble strip shall be omitted.
- Depths shown are the minimum requirement and may need to be increased in poor ground conditions. Verification should be sought from the Civil Engineer.

© NIHE 2015  
DRAWINGS NOT TO BE SCALED DUE TO PRINTING DISTORTION



<b>TITLE</b>  RUMBLE STRIP  typical cross section	DRAWN BY	SCALE	DATE
	<b>P&amp;S</b>	1:20	Mar 91
	DRAWING NO.	A(08.13)13	
	REV NO. & DATE	(4) 05/14	
REV NOTE: Updated to Roads Service Details			

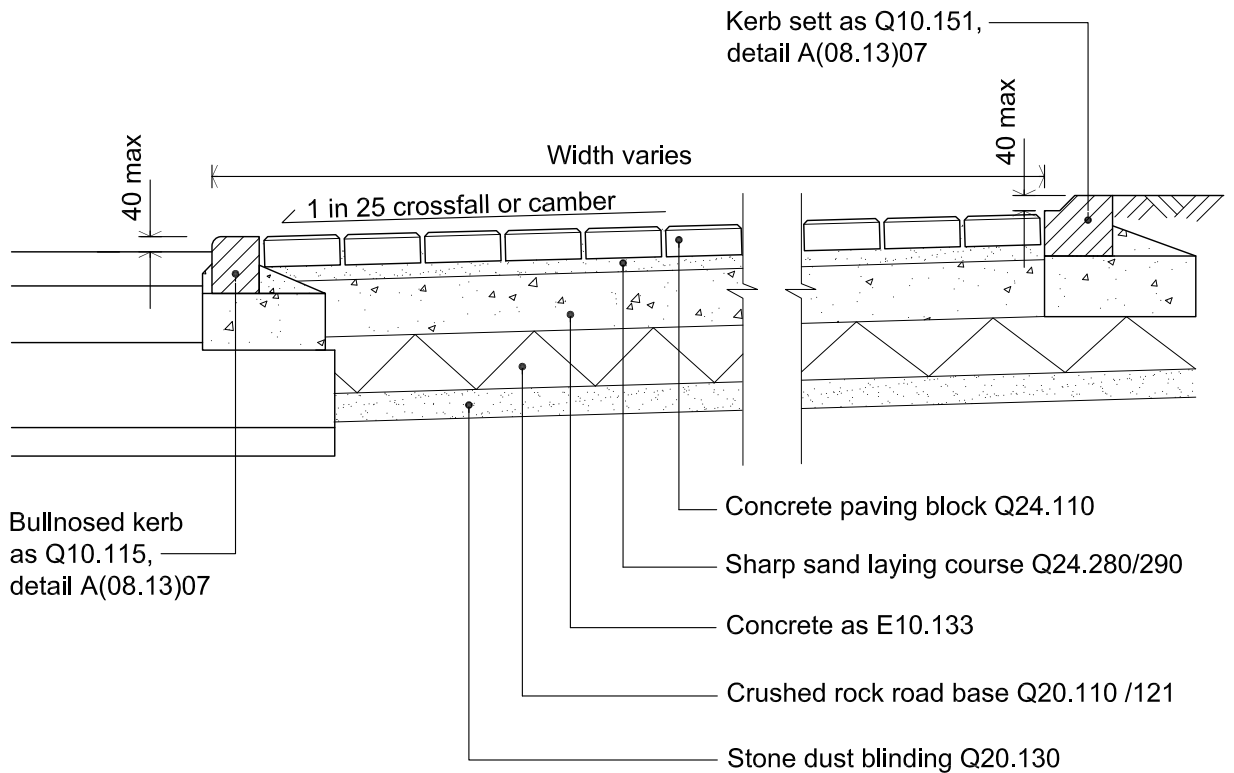

MOUNTABLE SHOULDER -- PAVING BLOCK CONSTRUCTION (mm)	
CONCRETE PAVING BLOCK	80
SAND LAYING COURSE	50
CONCRETE	150
CRUSHED ROCK ROAD BASE	150
STONE DUST BLINDING LAYER	75

**NOTES:**

- Depths shown are the minimum requirement and may need to be increased in poor ground conditions. Verification should be sought from the Civil Engineer.

© NIHE 2015  
DRAWINGS NOT TO BE SCALED DUE TO PRINTING DISTORTION



<b>TITLE</b> CONCRETE PAVOIR MOUNTABLE SHOULDER Typical cross section	<b>DRAWN BY</b> P&S	<b>SCALE</b> 1:20	<b>DATE</b> Mar 91
	<b>DRAWING NO.</b>	A(08.13)14	
	<b>REV NO. &amp; DATE</b>	(4) 05/14	
	<b>REV NOTE:</b> Updated to Roads Service Details		





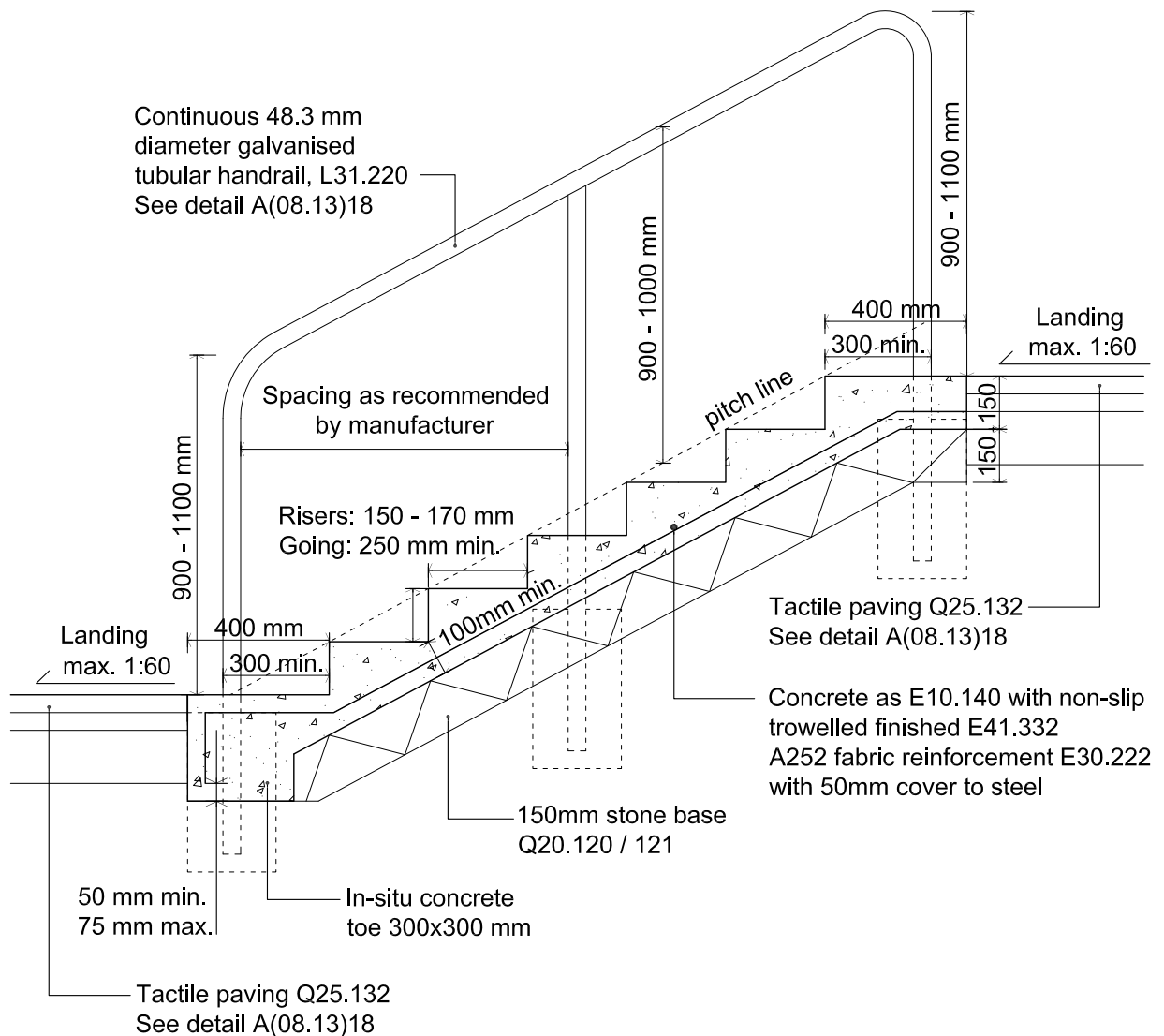

**NOTES:**

- As steps are not universally accessible they are only to be used as a last resort and where it is not possible to provide a ramp.
- Where possible, steps should comply with the current Building Control Technical Booklet H, for buildings other than dwellings.
- Steps should be 1.2 m to 1.8 m wide, with handrails fixed to both sides as A(08.13)10.
- If the adjacent ground level falls below the pitch line by more than 600 mm, include infill mesh as L31.222.
- A flight shall have a minimum of 2 risers and a maximum of 12.
- Going of landings should be at least equal to the width of the steps, with a gradient no steeper than 1:60.
- Depth of stone base is the minimum requirement and may need to be increased in poor ground conditions. Verification should be sought from the Civil Engineer.
- Seek Occupational Therapist (OT) advice if stepped ramps are recommended.

© NIHE 2015  
DRAWINGS NOT TO BE SCALED DUE TO PRINTING DISTORTION



<b>TITLE</b>  FOOTPATH STEPS in-situ concrete	<b>DRAWN BY</b> P&S	<b>SCALE</b> 1:20	<b>DATE</b> Mar 91
	<b>DRAWING NO.</b> A(08.13)17		
	<b>REV NO. &amp; DATE</b> (3) 07/14		
	<b>REV NOTE:</b> Updated to current Regs		



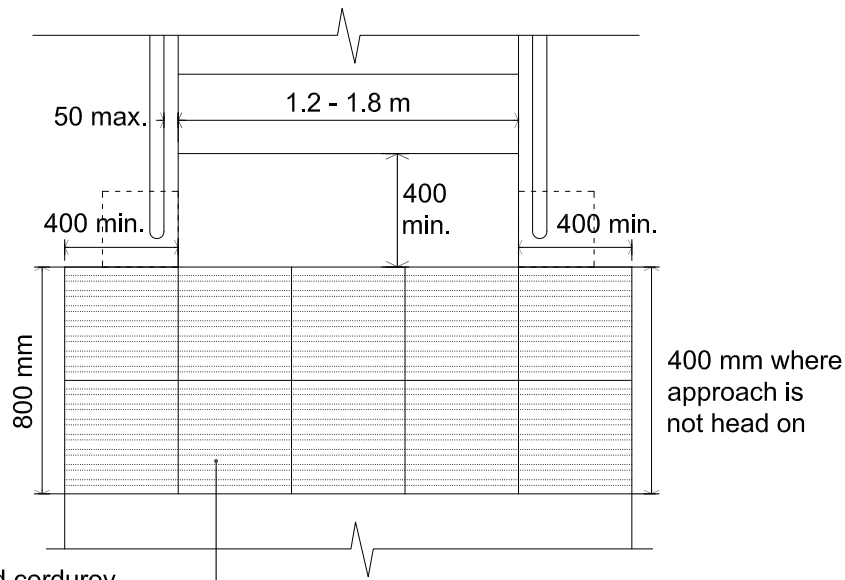

Buff coloured corduroy tactile paving as Q25.132 to top and bottom landings

PLAN (NTS)

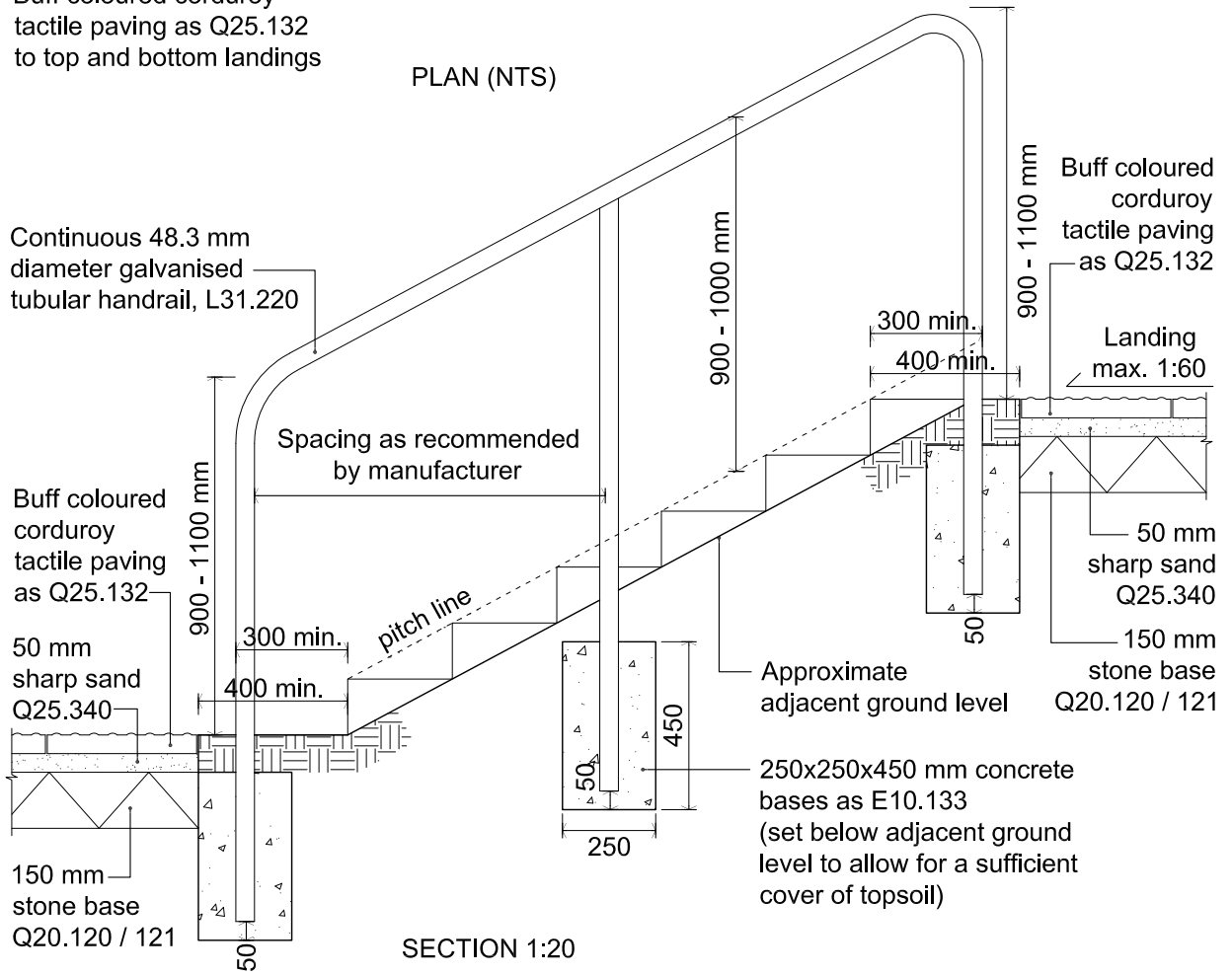

SECTION 1:20

NOTES:

- As steps and stepped ramps are not universally accessible they are only to be used as a last resort and where it is not possible to provide a ramp.
- Handrails should comply with the current Building Control Technical Booklet H, for buildings other than dwellings and should be fixed to both sides.
- If the adjacent ground level falls below the pitch line by more than 600 mm, include infill mesh as L31.222.
- See steps detail A(08.13)17 and stepped ramps detail A(08.13)16.

© NIHE 2015 DRAWINGS NOT TO BE SCALED DUE TO PRINTING DISTORTION



<p>TITLE</p> <p><b>HANDRAILS &amp; TACTILE WARNING SURFACE</b> for steps and stepped ramps</p>	<p>DRAWN BY</p> <p><b>P&amp;S</b></p>	<p>SCALE</p> <p><b>1:20</b></p>	<p>DATE</p> <p><b>Mar 91</b></p>
	<p>DRAWING NO.</p> <p><b>A(08.13)18</b></p>		
	<p>REV NO. &amp; DATE</p> <p><b>(3) 06/14</b></p>		
	<p>REV NOTE:</p> <p><b>Updated to current Regs</b></p>		

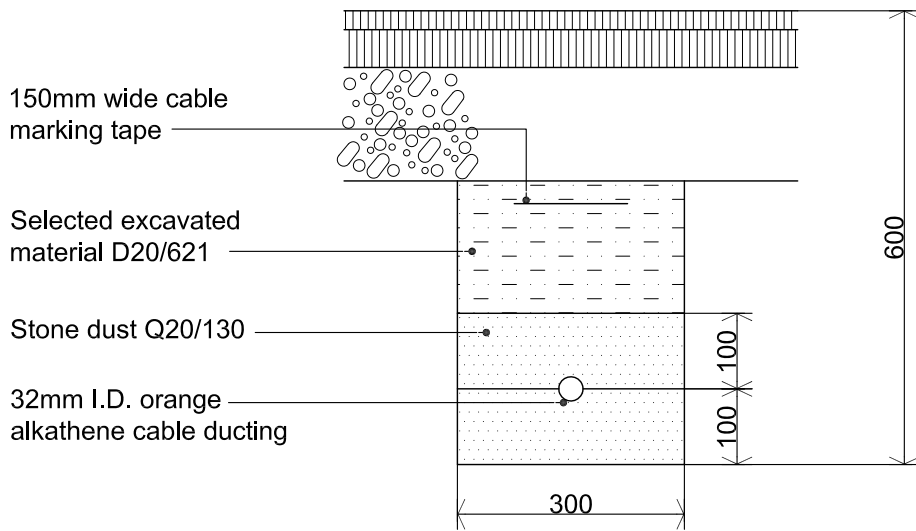

CABLE TRENCH  
IN FOOTWAY

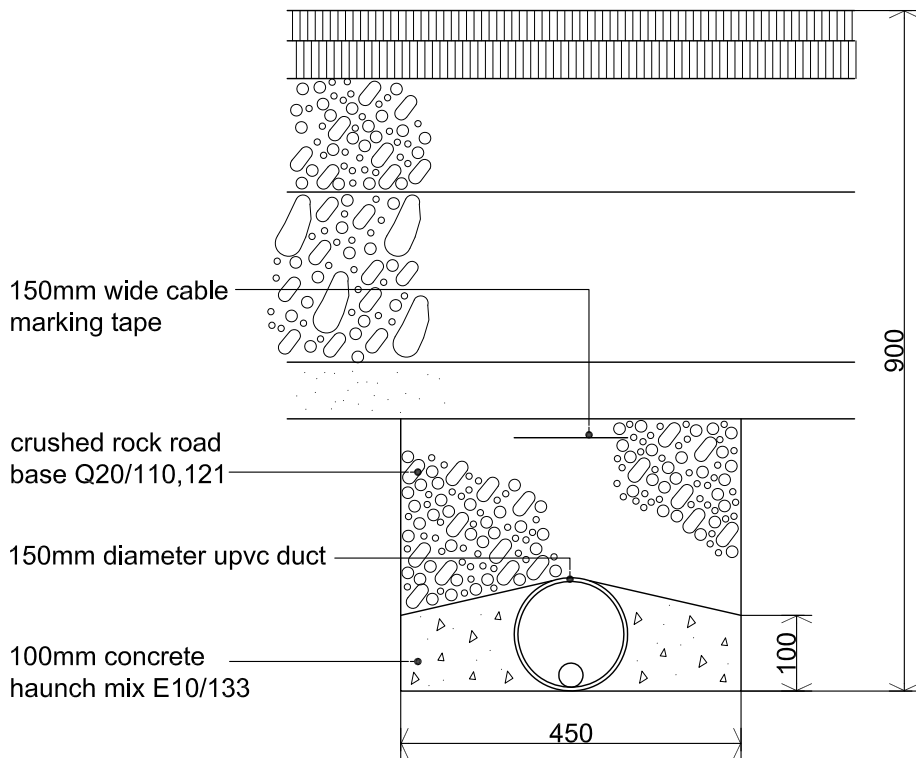

CABLE TRENCH  
IN CARRIAGEWAY

© NIHE 2015  
DRAWINGS NOT TO BE SCALED DUE TO PRINTING DISTORTION



<b>TITLE</b>  <b>STREET LIGHTING CABLE TRENCH DETAILS</b>	<b>DRAWN BY</b> LM/CB	<b>SCALE</b> 1:10	<b>DATE</b> Jun 99
	<b>DRAWING NO.</b>	A(08.13)21	
	<b>REV NO. &amp; DATE</b>	(2) 10/12	
	<b>REV NOTE:</b> Updated to revised spec		

D = 1800mm for 12m column  
 D = 1500mm for 10m column  
 D = 1200mm for 8m column  
 D = 1000mm for 6m column  
 D = 750mm for 5m column

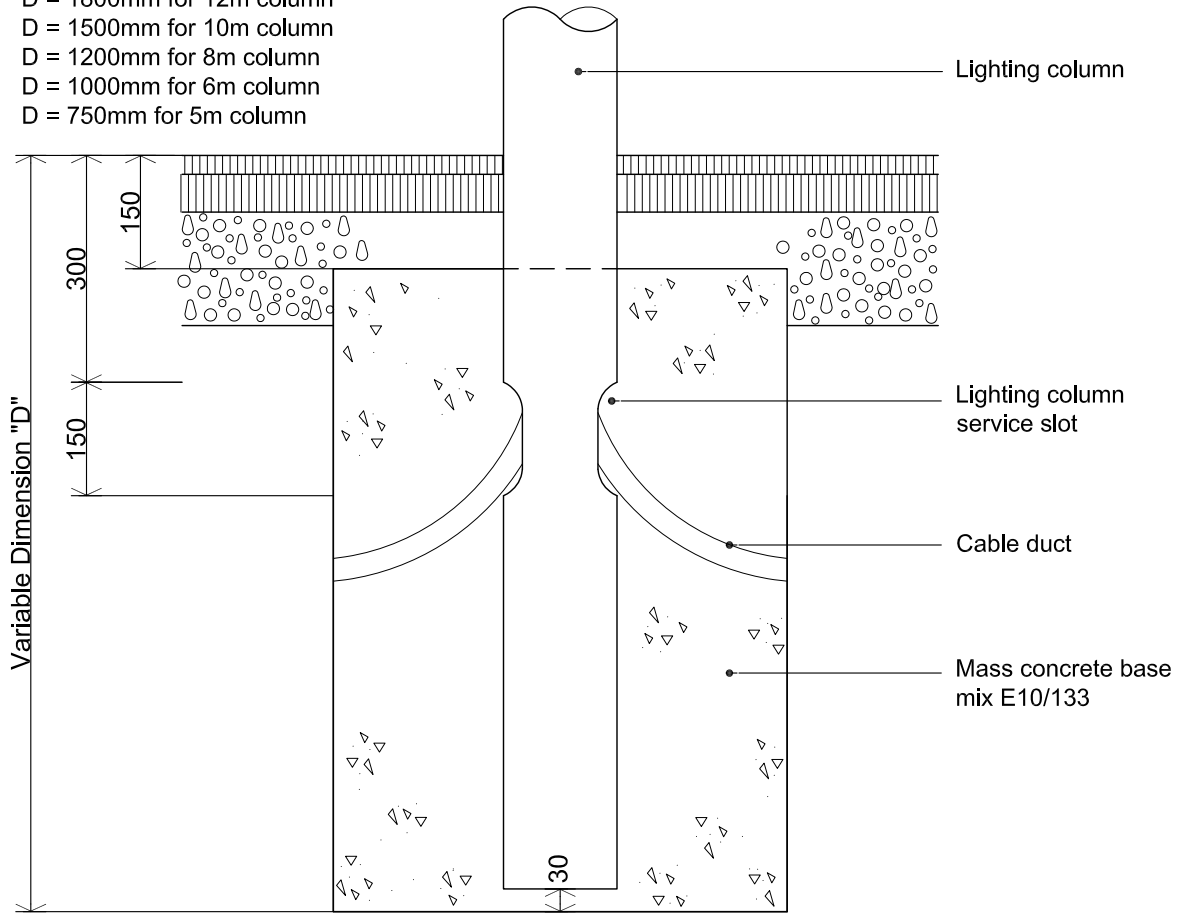

SECTION THROUGH COLUMN BASE

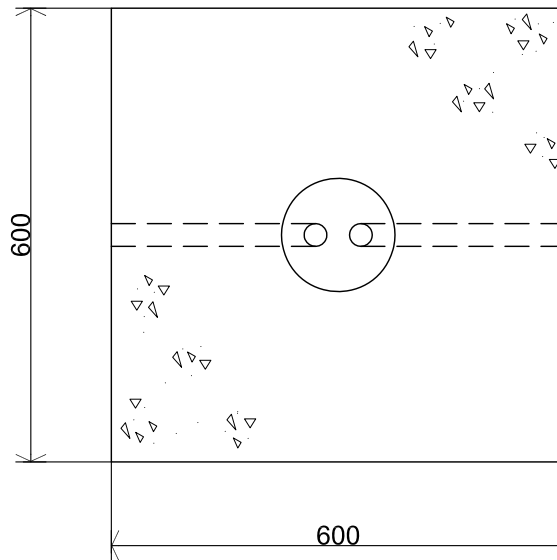

PLAN OF COLUMN BASE

© NIHE 2015  
 DRAWINGS NOT TO BE SCALED DUE TO PRINTING DISTORTION



TITLE	BASE DETAIL FOR ROOT TYPE COLUMN		
-------	----------------------------------	--	--

DRAWN BY	LM/CB	SCALE	1:10	DATE	Jun 99
DRAWING NO.	A(08.13)22				
REV NO. & DATE	(2) 10/12				
REV NOTE:	Updated to revised spec				

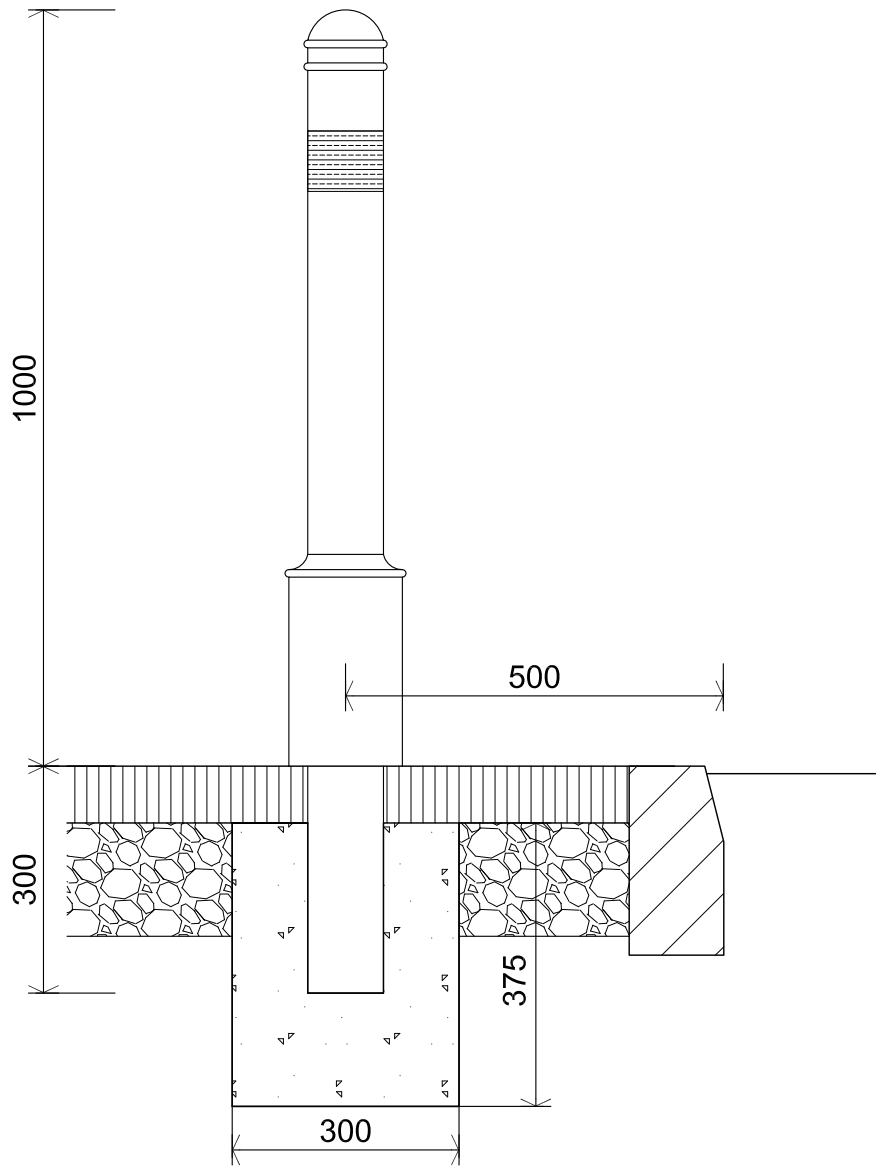

**TYPICAL BOLLARD DETAIL**

(for use at pedestrian crossing points and raised junctions)

**NOTE:**

1. Bollards manufactured in galvanised tubular steel and painted black.
2. Bollards set in concrete base 300x300x375 deep as E10/133
3. Bollards to be set back 500mm from face of kerb to centre of bollard
4. Bollards to have a 80mm minimum wide high intensity retroreflective band to BS EN 12899-1:2007

© NIHE 2015  
DRAWINGS NOT TO BE SCALED DUE TO PRINTING DISTORTION



<b>TITLE</b>  FOOTPATH BOLLARD	DRAWN BY <b>CB</b>	SCALE <b>1:10</b>	DATE <b>Sept 12</b>	
	DRAWING NO.		<b>A(08.13)27</b>	
	REV NO. & DATE			
	REV NOTE:			

\* This NIHE produced detail has been examined by The Building Control N.I. Standards Panel and has been considered reasonable in its interpretation of the relevant requirements of the Building Regulation NI 2012. There is no legal obligation for any Building Control department to adopt this recommendation & it is subject to revision in the event of changes to the legislation or other mitigating circumstances.

BRICK OR IN-SITU CONCRETE MANHOLE LESS THAN 1.4m DEEP TYPE A

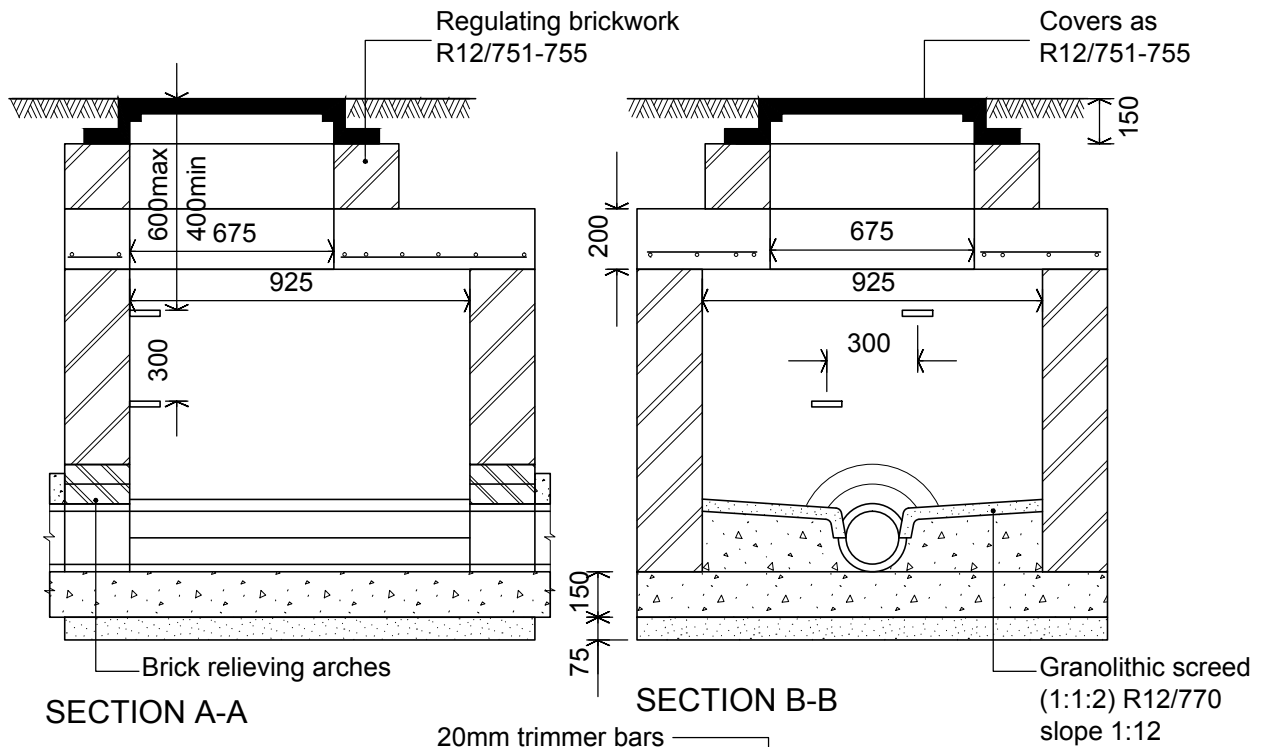

SECTION A-A

SECTION B-B

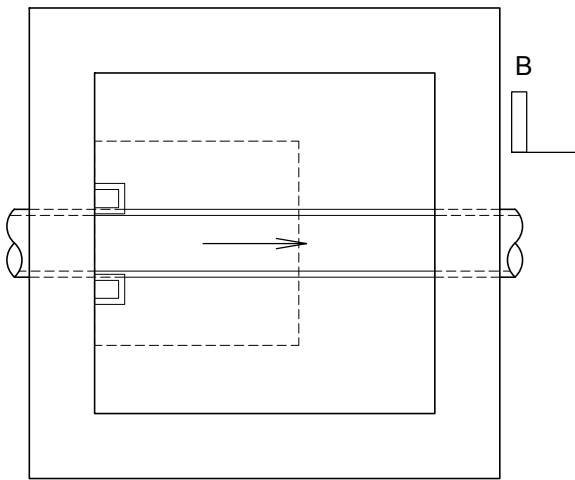

SECTIONAL PLAN

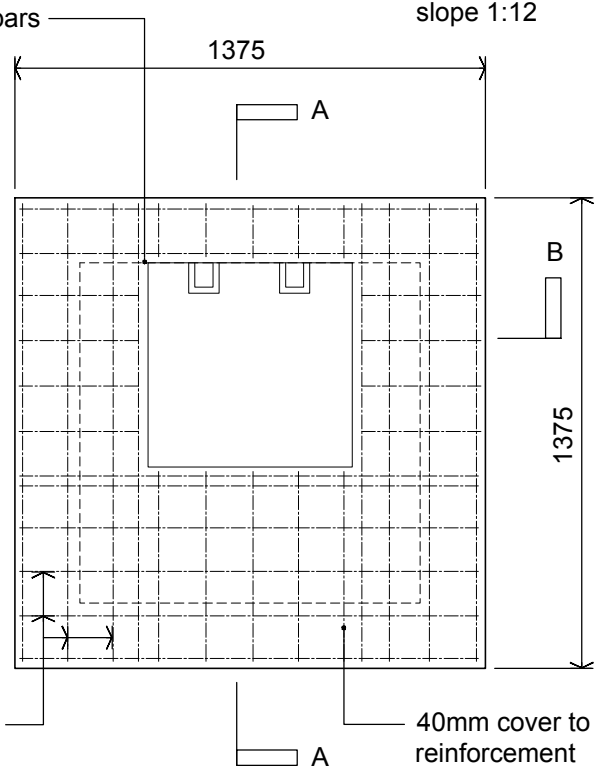

PLAN

NOTE:

The BCNI Standards Panel endorsement only applies to drainage systems within the curtilage of the building, not those adopted by N.I. Water.

SPECIFICATION REFERENCE R12/710



TITLE	MANHOLE TYPE A main foul/storm drainage (For repair purposes only)		
-------	--	--	--

DRAWN BY P&S	SCALE N.T.S.	DATE Dec 90
DRAWING NO.	A(08.14)01	
REV NO. & DATE	(2) 07/16	
REV NOTE: Updated for Building Control		



\* This NIHE produced detail has been examined by The Building Control N.I. Standards Panel and has been considered reasonable in its interpretation of the relevant requirements of the Building Regulation NI 2012. There is no legal obligation for any Building Control department to adopt this recommendation & it is subject to revision in the event of changes to the legislation or other mitigating circumstances.

### BRICK OR IN-SITU CONCRETE MANHOLE 1.4 TO 2.5m DEEP TYPE B

Regulating brickwork R12/751-755

cover to BS 497 R12/751-755

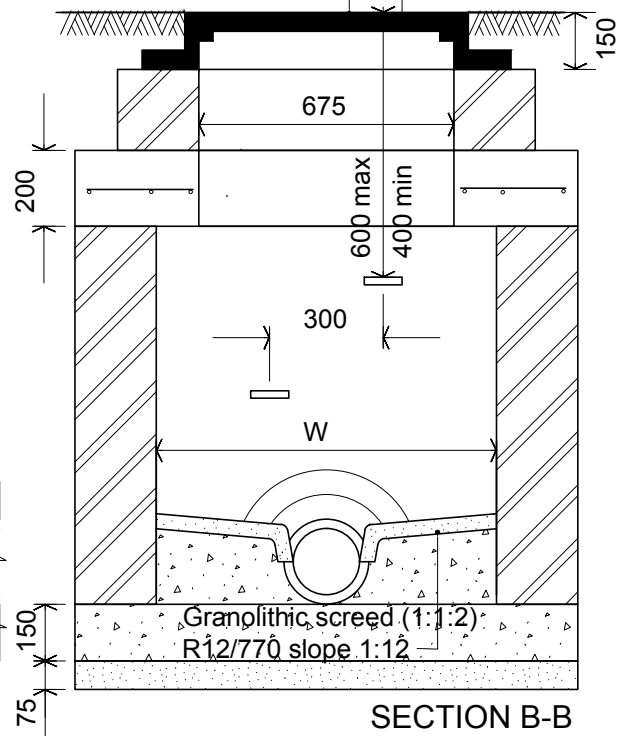
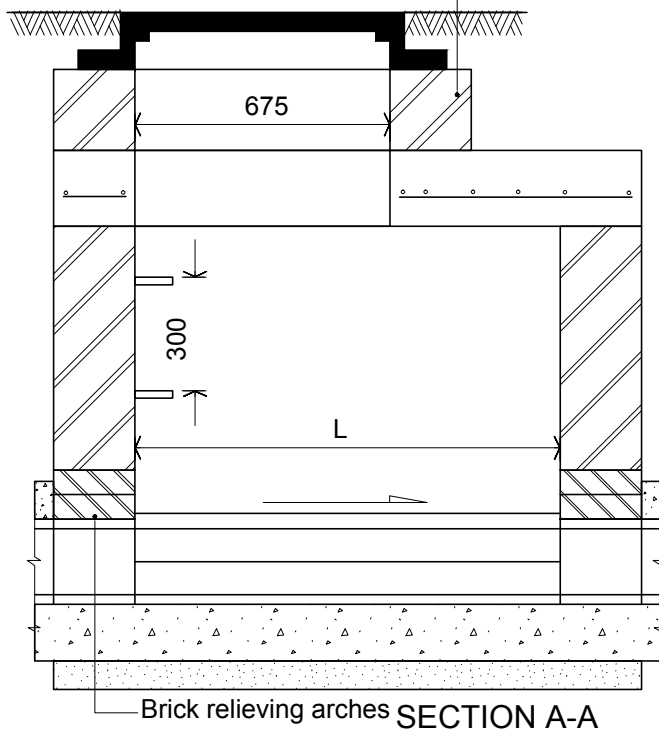

Pipe Diameter	Dimension	
	W	L
up to 375mm	925mm	1155mm
450 to 600mm	1155mm	1615mm

20mm trimmer bars around opening E30/140

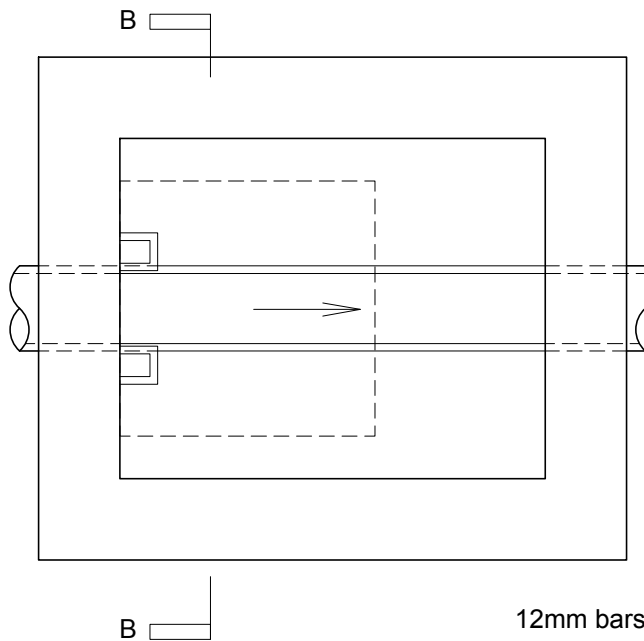

12mm bars at 150mm spacing E30/140

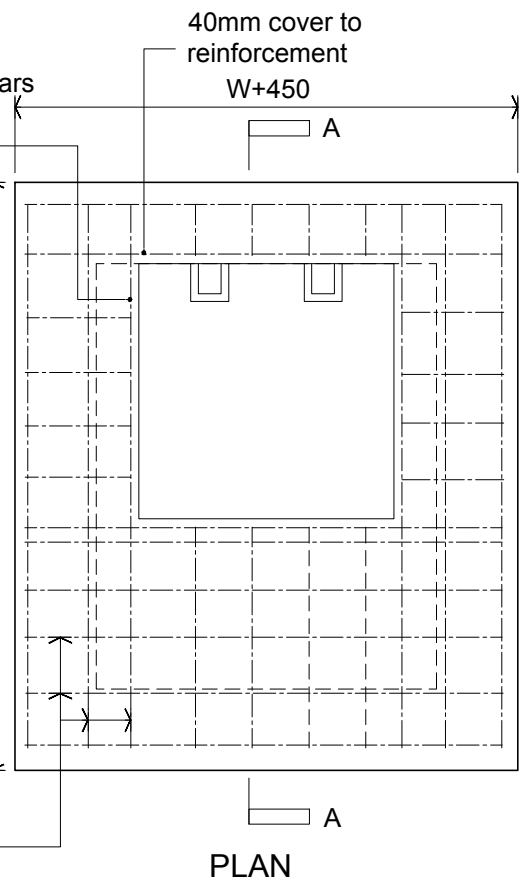

**NOTE:**

The BCNI Standards Panel endorsement only applies to drainage systems within the curtilage of the building, not those adopted by N.I. Water.

SPECIFICATION REFERENCE R12/710

**Housing Executive**

*BCNI Standards Panel Agreed \**

TITLE

**MANHOLE TYPE B  
main foul/storm drainage  
(For repair purposes only)**

DRAWN BY <b>P&amp;S</b>	SCALE <b>N.T.S.</b>	DATE <b>Dec 90</b>
DRAWING NO.	<b>A(08.14)02</b>	
REV NO. & DATE	<b>(3) 07/16</b>	
REV NOTE: <b>Updated for Building Control</b>		



© NIHE 2017 DRAWINGS NOT TO BE SCALED DUE TO PRINTING DISTORTION

\* This NIHE produced detail has been examined by The Building Control N.I. Standards Panel and has been considered reasonable in its interpretation of the relevant requirements of the Building Regulation NI 2012. There is no legal obligation for any Building Control department to adopt this recommendation & it is subject to revision in the event of changes to the legislation or other mitigating circumstances.

**BRICK OR IN-SITU CONCRETE MANHOLE 2.5 TO 3.5m DEEP TYPE C**

cover to BS 497  
R12/751-755

regulating brickwork  
R12/751-755

Access ladder C(08.14)01  
600mm max to top rung

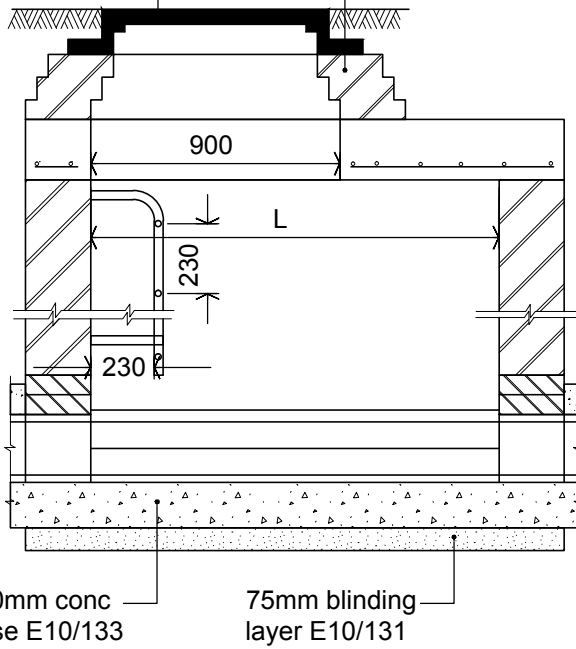

**SECTION A-A**

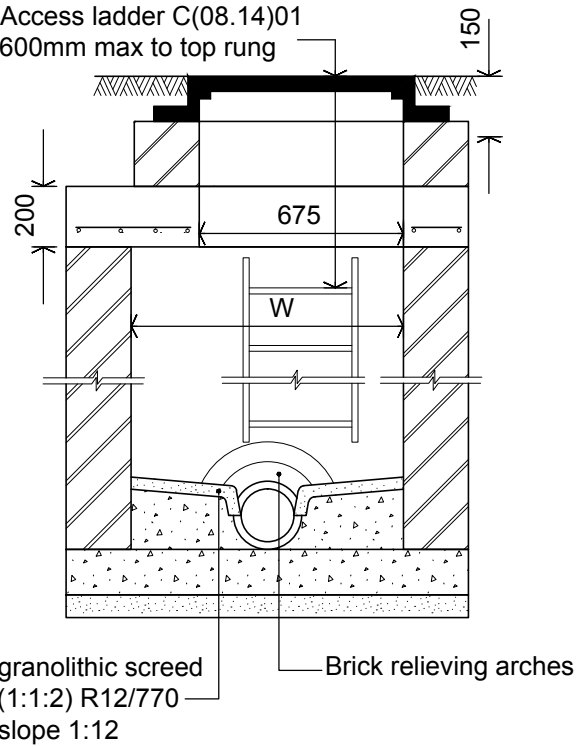

**SECTION B-B**

Pipe Diameter	Dimension	
	W	L
up to 375mm	925mm	1155mm
450 to 600mm	1155mm	1615mm

20mm trimmer bars  
around opening  
E30/140

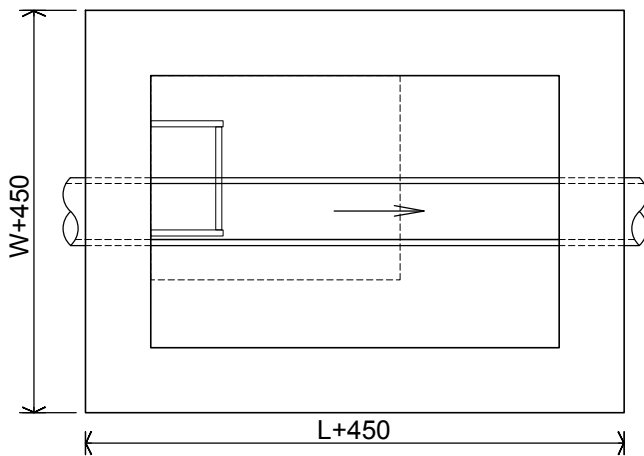

**SECTIONAL PLAN**

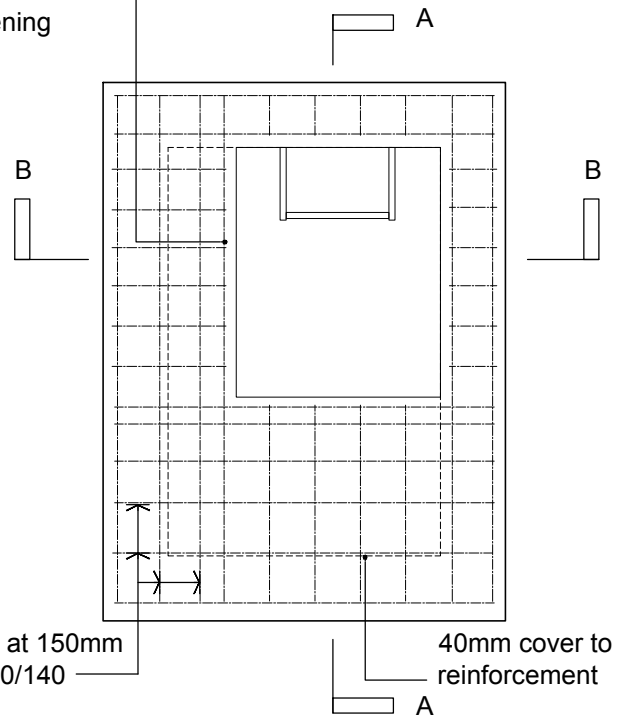

**ROOF PLAN**

**NOTE:**

The BCNI Standards Panel endorsement only applies to drainage systems within the curtilage of the building, not those adopted by N.I. Water.

SPECIFICATION REFERENCE R12/710

TITLE

**MANHOLE TYPE C**  
main foul/storm drainage  
(For repair purposes only)

DRAWN BY <b>P&amp;S</b>	SCALE <b>N.T.S.</b>	DATE <b>Dec 90</b>
DRAWING NO.	<b>A(08.14)03</b>	
REV NO. & DATE	<b>4 (07/16)</b>	
REV NOTE: Updated for Building Control		





\* This NIHE produced detail has been examined by The Building Control N.I. Standards Panel and has been considered reasonable in its interpretation of the relevant requirements of the Building Regulation NI 2012. There is no legal obligation for any Building Control department to adopt this recommendation & it is subject to revision in the event of changes to the legislation or other mitigating circumstances.

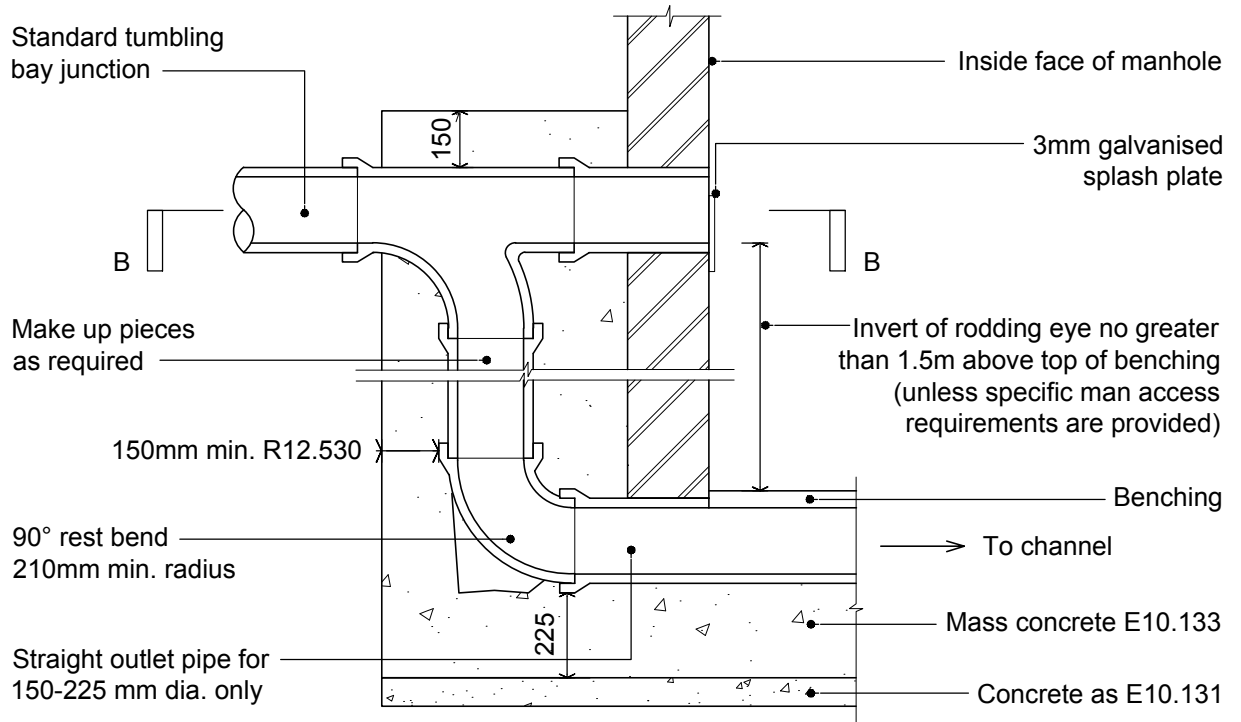

SECTION A-A

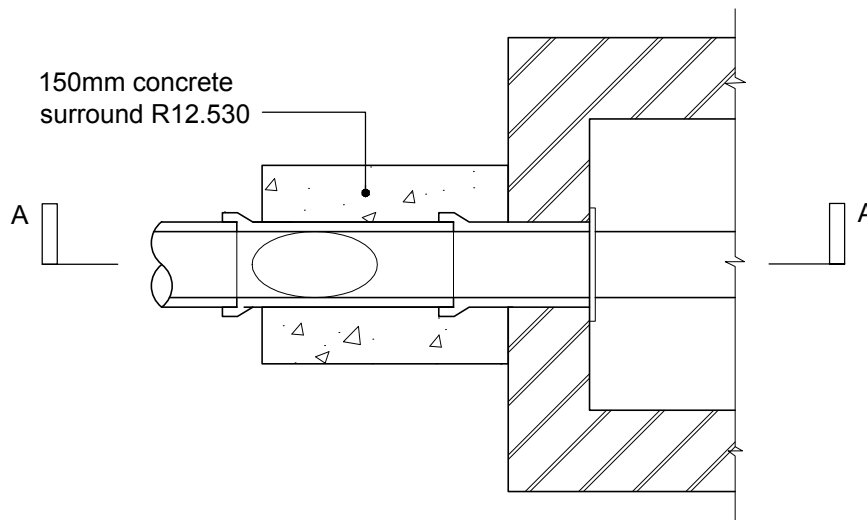

SECTION B-B

**NOTES:**

- The BCNI Standards Panel endorsement only applies to drainage systems within the curtilage of the building, not those adopted by N.I. Water.
- Backdrops should be constructed in accordance with BS EN 752: 'Drain and sewer systems outside buildings' and NIW document 'Sewers for Adoption - Northern Ireland'.
- Provide access to the higher pipe and to the vertical drop pipe for inspection and maintenance.
- Where the difference in level is less than 1.8 m, a 45° ramp is preferable to a vertical drop pipe.
- For pipe diameters larger than 225 mm, bends are to be built through the manhole wall.

© NIHE 2017 DRAWINGS NOT TO BE SCALED DUE TO PRINTING DISTORTION



TITLE	TYPICAL DROP CONNECTION		
	Main foul/storm drainage - brick or concrete manhole		

DRAWN BY	P&S	SCALE	1:20	DATE	Nov 90
DRAWING NO.	A(08.14)05				
REV NO. & DATE	(4) 07/16				
REV NOTE:	Notes updated to NIW standards				



PRECAST CONCRETE CIRCULAR MANHOLE LESS THAN 3M DEEP - NIW A

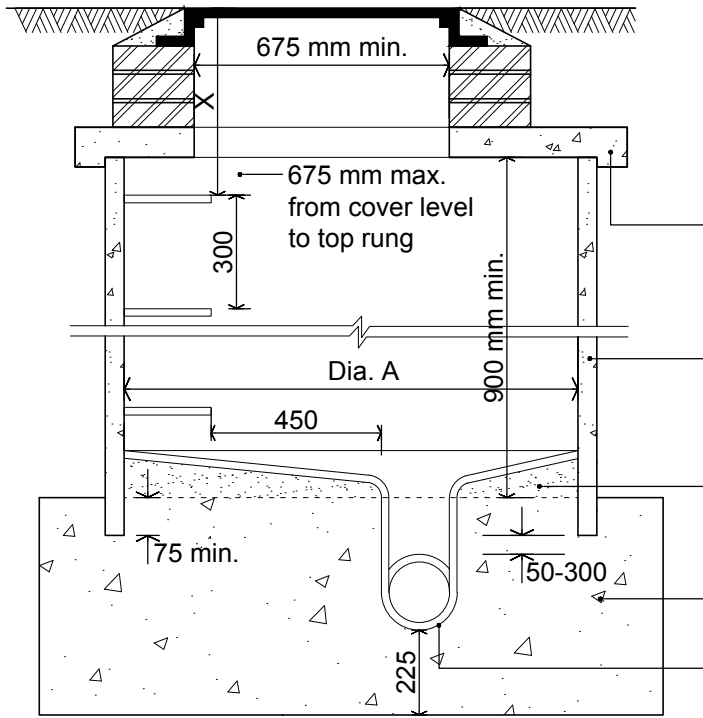

SECTION

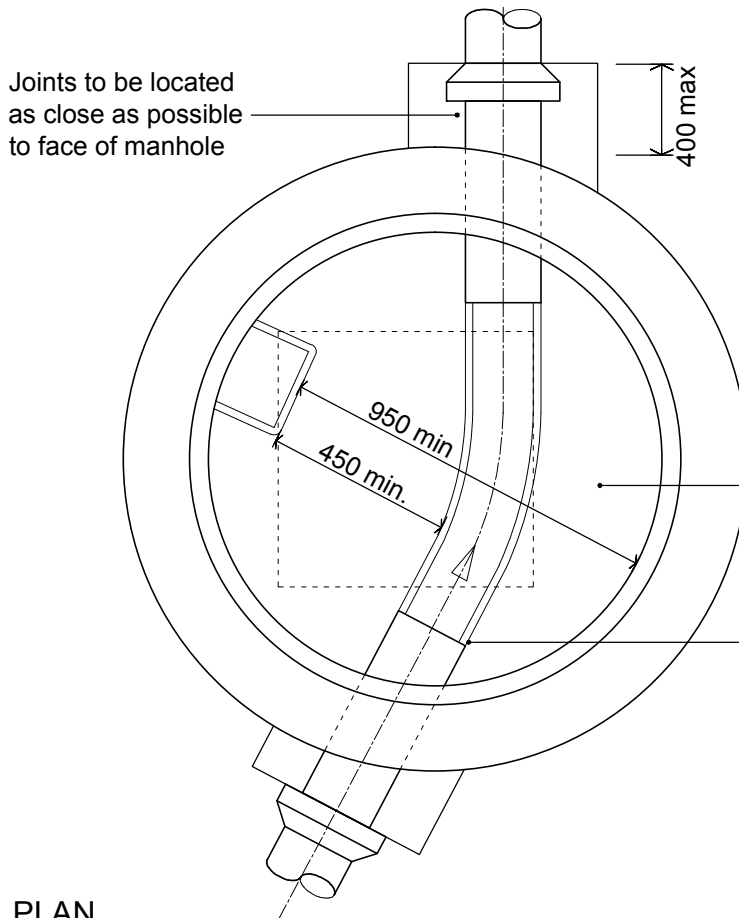

PLAN

Pipe Diameter (mm)	Dimension A (mm)
Less than 375	1200
375 to 450	1350
500 to 700	1500

Minimum width of benching 225 mm

Pipe joint with a channel to be located min. 100 mm inside face of manhole

**NOTE:**  
In poor/aggressive ground conditions a full depth concrete surround is required and should be designed to BRE Special Digest 1 Concrete in Aggressive Ground

© NIHE 2017 DRAWINGS NOT TO BE SCALED DUE TO PRINTING DISTORTION



TITLE  
TYPICAL MANHOLE - NIW A  
up to 3 m deep

DRAWN BY <b>P&amp;S</b>	SCALE <b>1:20</b>	DATE <b>Nov 90</b>
DRAWING NO.	<b>A(08.14)06</b>	
REV NO. & DATE	<b>(4) 06/14</b>	
REV NOTE: <b>Updated to NIW details</b>		

\* This NIHE produced detail has been examined by The Building Control N.I. Standards Panel and has been considered reasonable in its interpretation of the relevant requirements of the Building Regulation NI 2012. There is no legal obligation for any Building Control department to adopt this recommendation & it is subject to revision in the event of changes to the legislation or other mitigating circumstances.

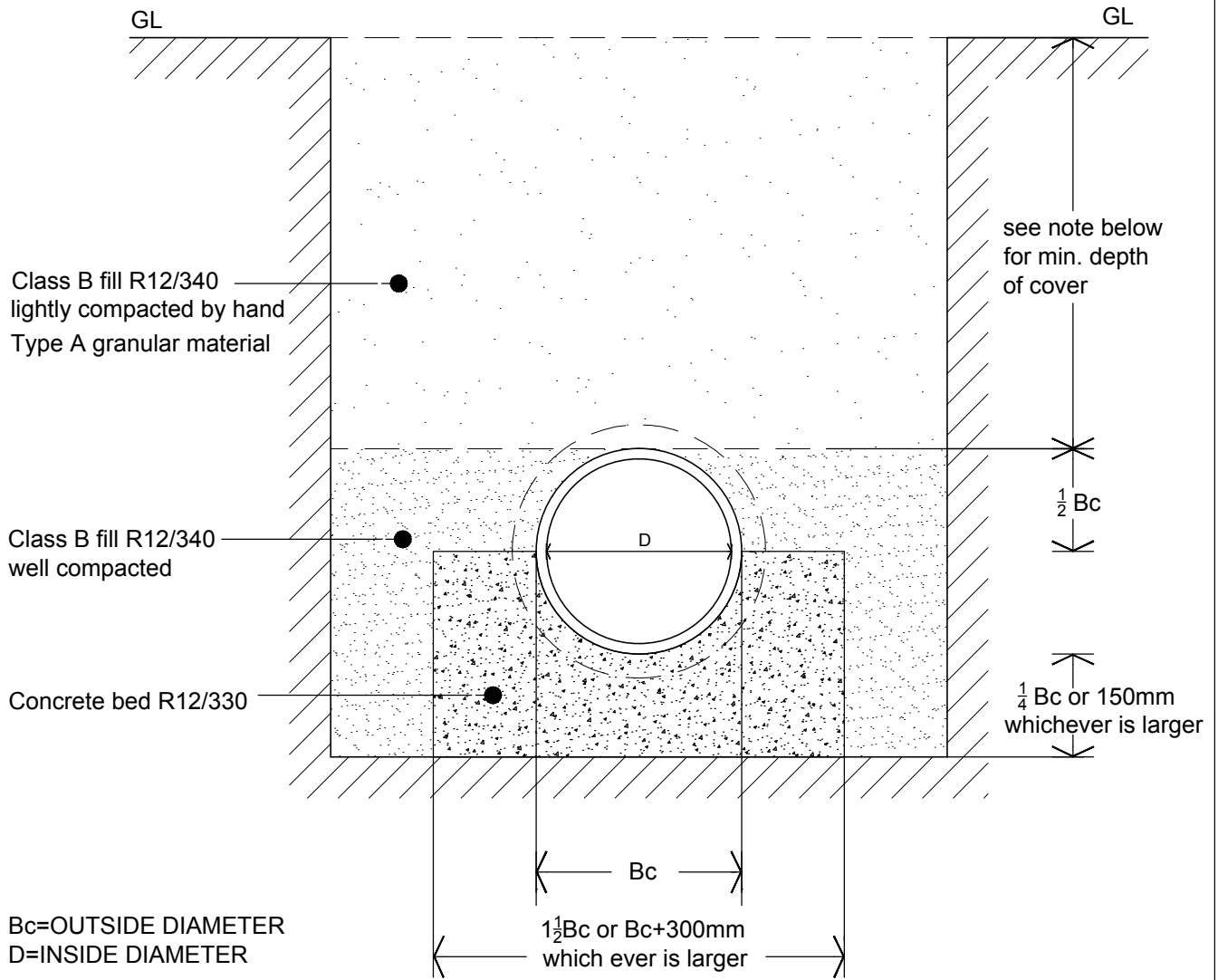

**NOTES:**

- Min. Depth of Cover without protection: 0.75m for garden & open spaces (with no possibility of vehicular access), 0.9m for Agricultural land & 1.2m for driveways, footpaths, street & parking areas.
- Type B fill will be suitable granular material free from stones larger than 40mm, lumps of clay over 100mm, timber, frozen materials and vegetable matter as in Tech Booklet N: 2012 Page 21 Key & notes to dia. 3.2 & 3.3.
- Buried pipes to be designed to BS EN 1295-1 & BS 9295.
- Where a pipe has < the min. depth of cover but > 600mm, Detail B in A(08.14)10 should be applied.
- If the depth of cover is below 600mm see detail A(08.14)12 Concrete Surround.
- Concrete surround also required if trench is in close proximity to foundations. See detail A(01.10)01.
- Granular material should conform to BS EN 1610.
- The BCNI Standards Panel endorsement only applies to drainage systems within the curtilage of a building, not those adopted by N.I. Water.

Spec Ref: R12.330



TITLE  CLASS A BEDDING PLAIN CONCRETE bedding for rigid pipes	DRAWN BY P&S	SCALE 1:5	DATE Aug 90
	DRAWING NO.	A(08.14)07	
	REV NO. & DATE	(3) 07/16	
	REV NOTE:	Update for Building Control	



\* This NIHE produced detail has been examined by The Building Control N.I. Standards Panel and has been considered reasonable in its interpretation of the relevant requirements of the Building Regulation NI 2012. There is no legal obligation for any Building Control department to adopt this recommendation & it is subject to revision in the event of changes to the legislation or other mitigating circumstances.

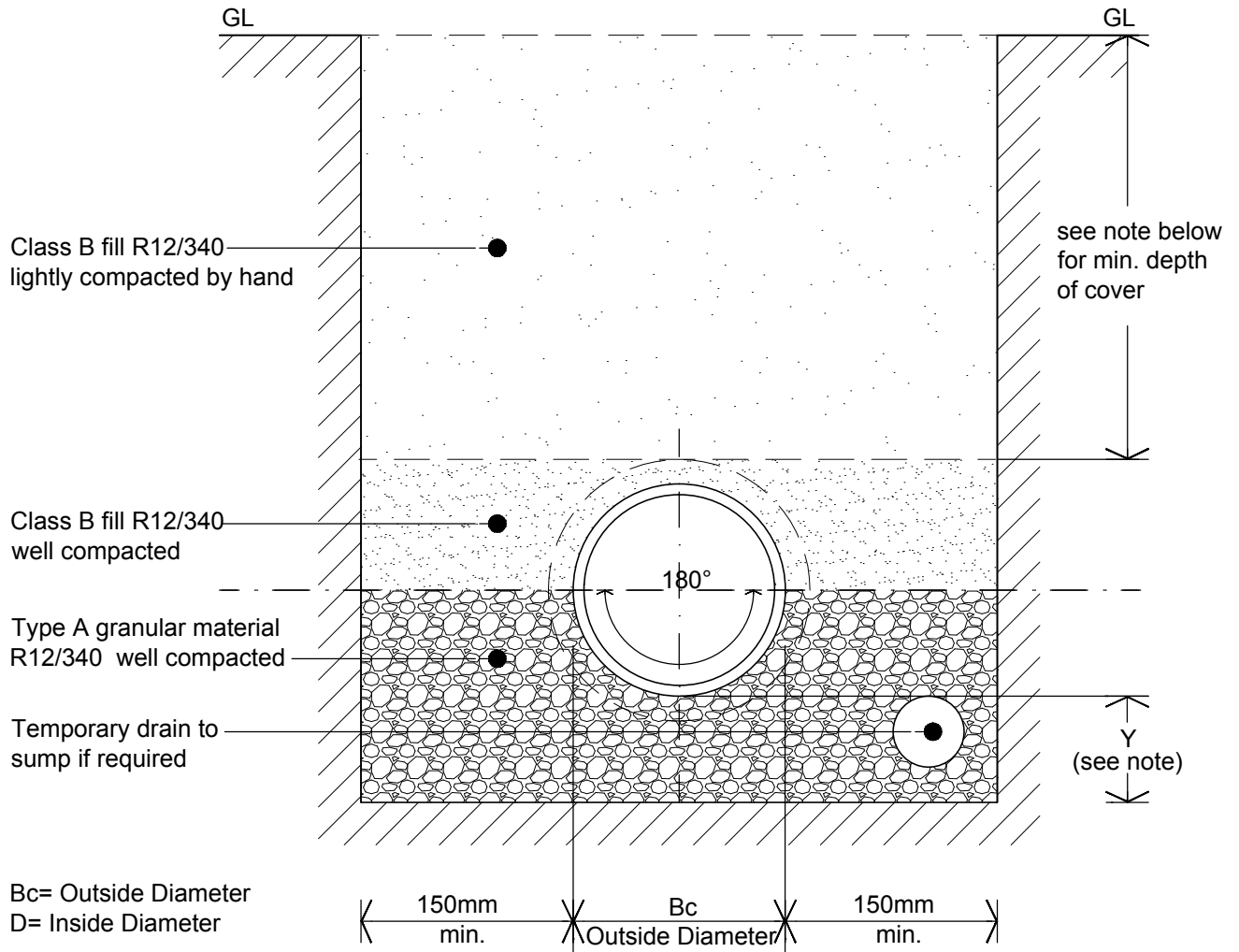

#### NOTES:

- Min. Depth of Cover without protection: 0.75m for garden & open spaces (with no possibility of vehicular access) 0.9m for Agricultural land & 1.2m for driveways, footpaths, street & parking areas.
- Buried pipes to be designed to BS EN 1295-1 & BS 9295.
- Type B granular material to be free from stones larger than 40mm, lumps of clay over 100mm, timber, frozen materials and vegetable matter, as in Tech Booklet N: 2012 Pg. 21, dia. 3.2 and 3.3.
- Where a pipe has < the min. depth of cover but > 600mm, Detail B in A(08.14)10 should be applied.
- If the depth of cover is below 600mm see detail A(08.14)12 Concrete Surround.
- Concrete surround also required if trench is in close proximity to foundations. See detail A(01.10)01.
- The BCNI Standards Panel endorsement only applies to drainage systems within the curtilage of a building, not those adopted by N.I. Water.

#### DIMENSION Y:

- For Trenches in rock or mixed soils containing rock bands, boulders, large flints or stones or other irregular hard spots,  $Y = \frac{1}{4} Bc$  or 200mm (whichever is the greater) under the barrels, but not less than 200mm under the sockets.
- For trenches in uniform soils  $Y = \frac{1}{6} Bc$  or 100mm (whichever is the greater) under the barrels, but not less than 50mm under the sockets.

Spec Ref: R12.340



TITLE  CLASS B BEDDING main foul/storm drainage bedding for rigid pipes	DRAWN BY <b>P&amp;S</b>	SCALE <b>1:5</b>	DATE <b>Aug 90</b>
	DRAWING NO.	<b>A(08.14)08</b>	
	REV NO. & DATE	<b>(3) 07/16</b>	
	REV NOTE: Updated for Building Control		

\* This NIHE produced detail has been examined by The Building Control N.I. Standards Panel and has been considered reasonable in its interpretation of the relevant requirements of the Building Regulation NI 2012. There is no legal obligation for any Building Control department to adopt this recommendation & it is subject to revision in the event of changes to the legislation or other mitigating circumstances.

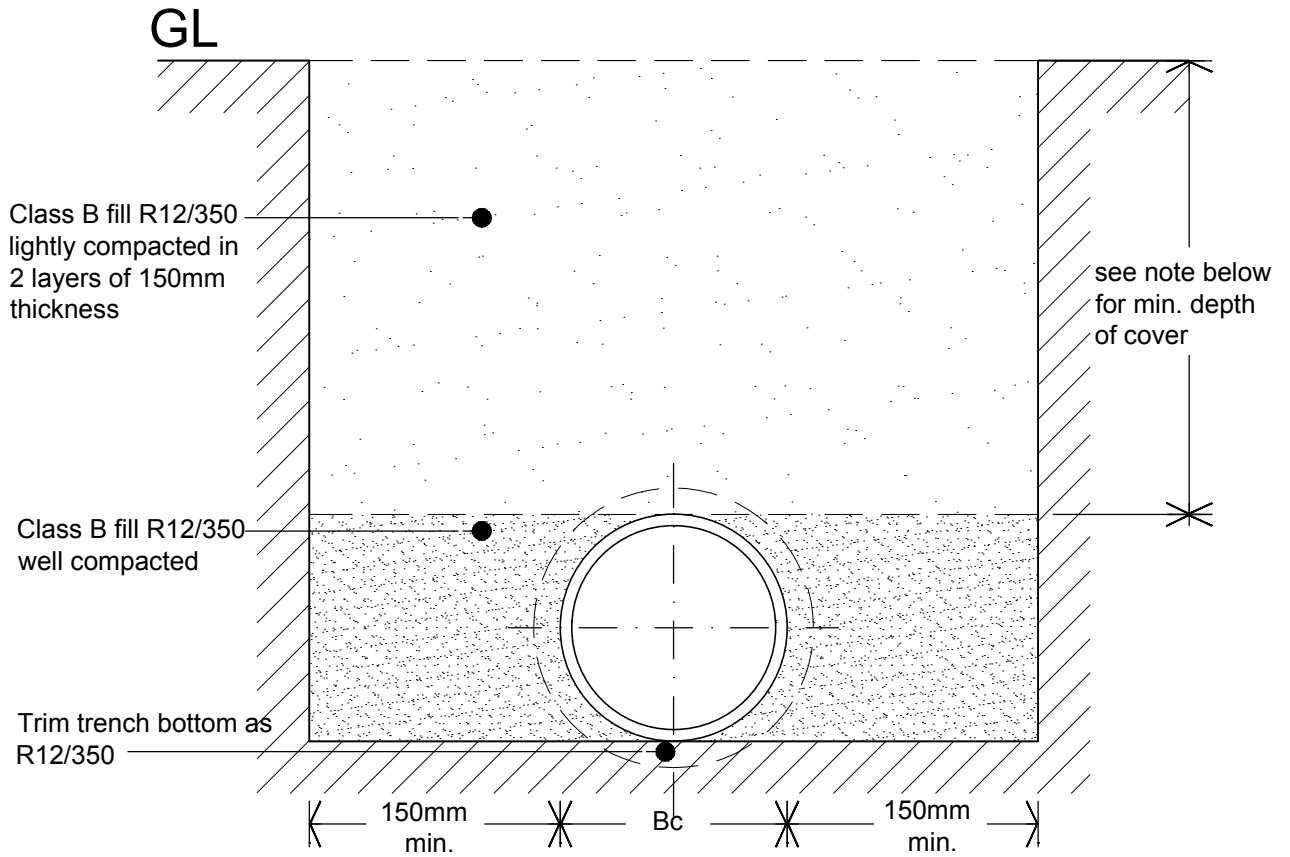

Bc=OUTSIDE DIAMETER

**NOTES-**

- Min. Depth of Cover without protection: 0.75m for garden & open spaces (with no possibility of vehicular access), 0.9m for Agricultural land & 1.2m for driveways, footpaths, street & parking areas.
- Type B granular material to be free from stones larger than 40mm, lumps of clay over 100mm, timber, frozen materials and vegetable matter, as in Tech Booklet N: 2012 Pg. 21, dia. 3.2 and 3.3.
- Buried pipes to be designed to BS EN 1295-1 & BS 9295.
- Where a pipe has < the min. depth of cover but > 600mm, Detail B in A(08.14)10 should be applied.
- If the depth of cover is below 600mm see detail A(08.14)12 Concrete Surround.
- Concrete surround also required if trench is in close proximity to foundations. See detail A(01.10)01.
- The BCNI Standards Panel endorsement only applies to drainage systems within the curtilage of a building, not those adopted by N.I. Water.

Spec Ref: R12.350



TITLE	CLASS D NATURAL BEDDING main foul/storm drainage bedding for rigid pipes
-------	---

DRAWN BY P&S	SCALE 1:5	DATE Aug 90
DRAWING NO.	A(08.14)09	
REV NO. & DATE	(3) 07/16	
REV NOTE: Updated for Building Control		

© NIHE 2017  
DRAWINGS NOT TO BE SCALED DUE TO PRINTING DISTORTION

\* This NIHE produced detail has been examined by The Building Control N.I. Standards Panel and has been considered reasonable in its interpretation of the relevant requirements of the Building Regulation NI 2012. There is no legal obligation for any Building Control department to adopt this recommendation & it is subject to revision in the event of changes to the legislation or other mitigating circumstances.

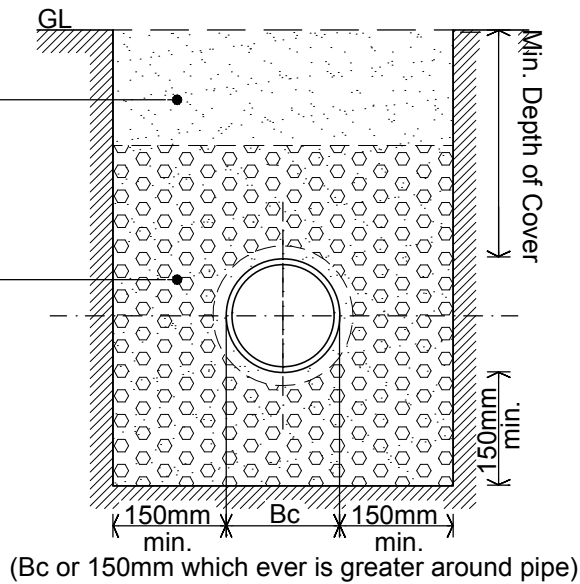

**DETAIL A**  
**FLEXIBLE PIPE CLASS S BEDDING**

**NOTES**

- Min. Depth of Cover: 0.75m for garden & open spaces (with no possibility of vehicular access), 0.9m for Agricultural land & 1.2m for driveways, footpaths, street & parking areas

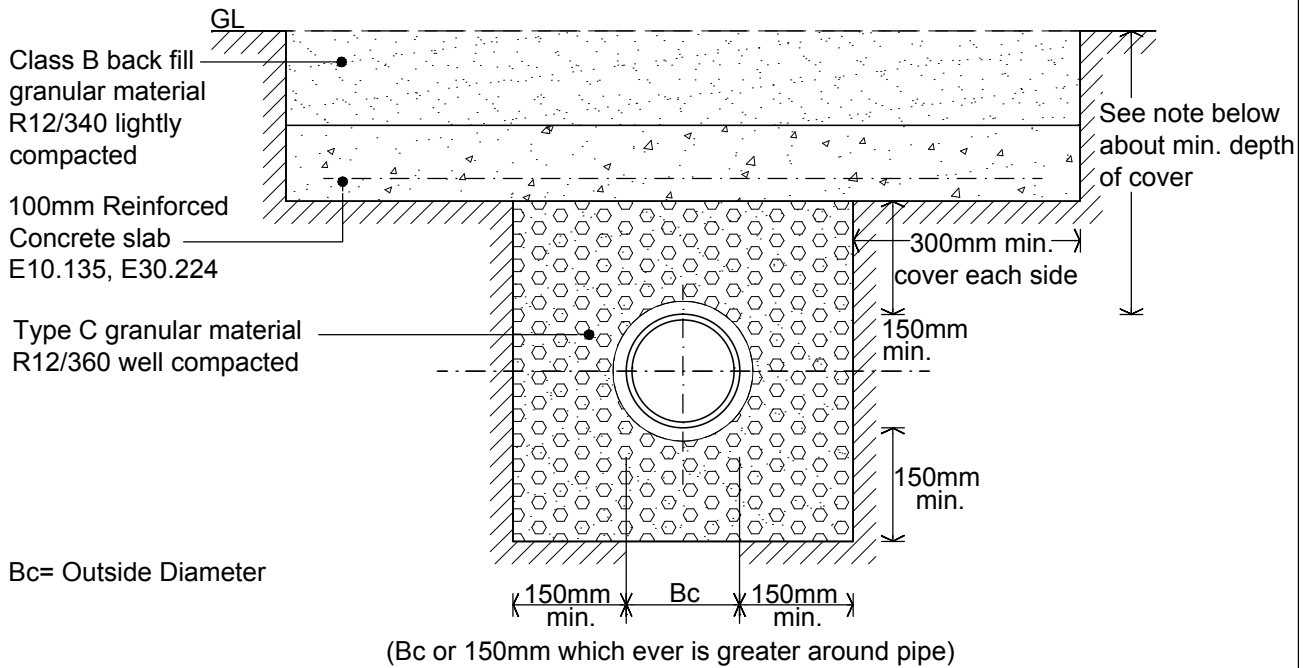

**DETAIL B**  
**FLEXIBLE PIPE CLASS S BEDDING- (see notes)**

**NOTES:**

- Where a pipe has < the min. depth of cover but > 600mm, Detail B should be applied.
- If the depth of cover is below 600mm see detail A(08.14)12 Concrete Surround.
- Concrete surround also required if trench is in close proximity to foundations. See detail A(01.10)01.
- The BCNI Standards Panel endorsement only applies to drainage systems within the curtilage of a building, not those adopted by N.I. Water.

© NIHE 2017  
DRAWINGS NOT TO BE SCALED DUE TO PRINTING DISTORTION



TITLE	DRAWN BY	SCALE	DATE
CLASS S BEDDING main foul/storm drainage flexible pipes	P&S	1:10	Aug 90
	DRAWING NO.	A(08.14)10	
	REV NO. & DATE	(5) 07/16	
	REV NOTE:	Updated for Building Control	

--	--

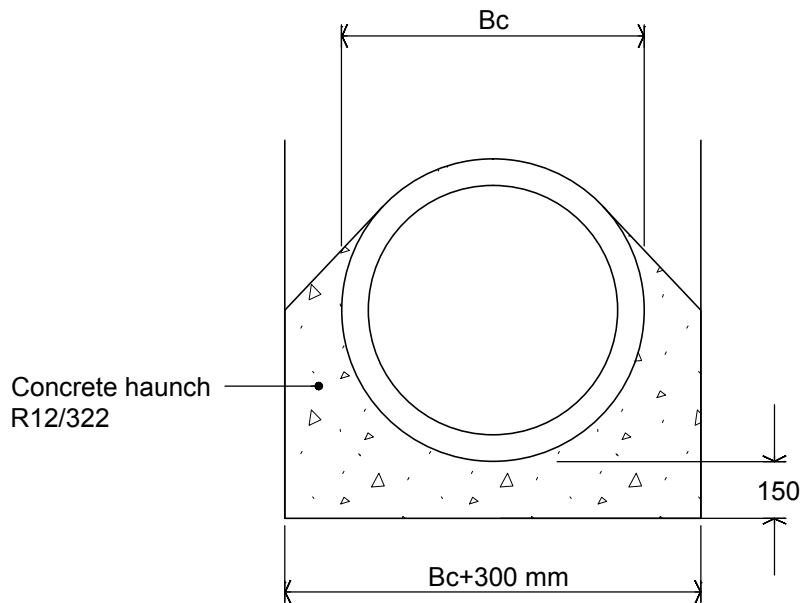

**NOTES:**

- The BCNI Standards Panel endorsement only applies to drainage systems within the curtilage of a building, not those adopted by N.I. Water.
- $B_c$  = OUTSIDE DIAMETER.
- For pipe jointing detail see drawing no. A(08.14)12.
- Concrete surround also required if trench is in close proximity to foundations. See detail A(01.10)01.



TITLE	DRAWN BY <b>P&amp;S</b>			SCALE <b>1:20</b>	DATE <b>Aug 90</b>
CONCRETE BED AND HAUNCH main foul/storm drainage	DRAWING NO.		A(08.14)11		
	REV NO. & DATE		(3) 07/16		
REV NOTE: Updated for Building Control					

DRAWN BY <b>P&amp;S</b>		SCALE <b>1:20</b>	DATE <b>Aug 90</b>
DRAWING NO.		A(08.14)11	
REV NO. & DATE		(3) 07/16	
REV NOTE: Updated for Building Control			



\* This NIHE produced detail has been examined by The Building Control N.I. Standards Panel and has been considered reasonable in its interpretation of the relevant requirements of the Building Regulation NI 2012. There is no legal obligation for any Building Control department to adopt this recommendation & it is subject to revision in the event of changes to the legislation or other mitigating circumstances.

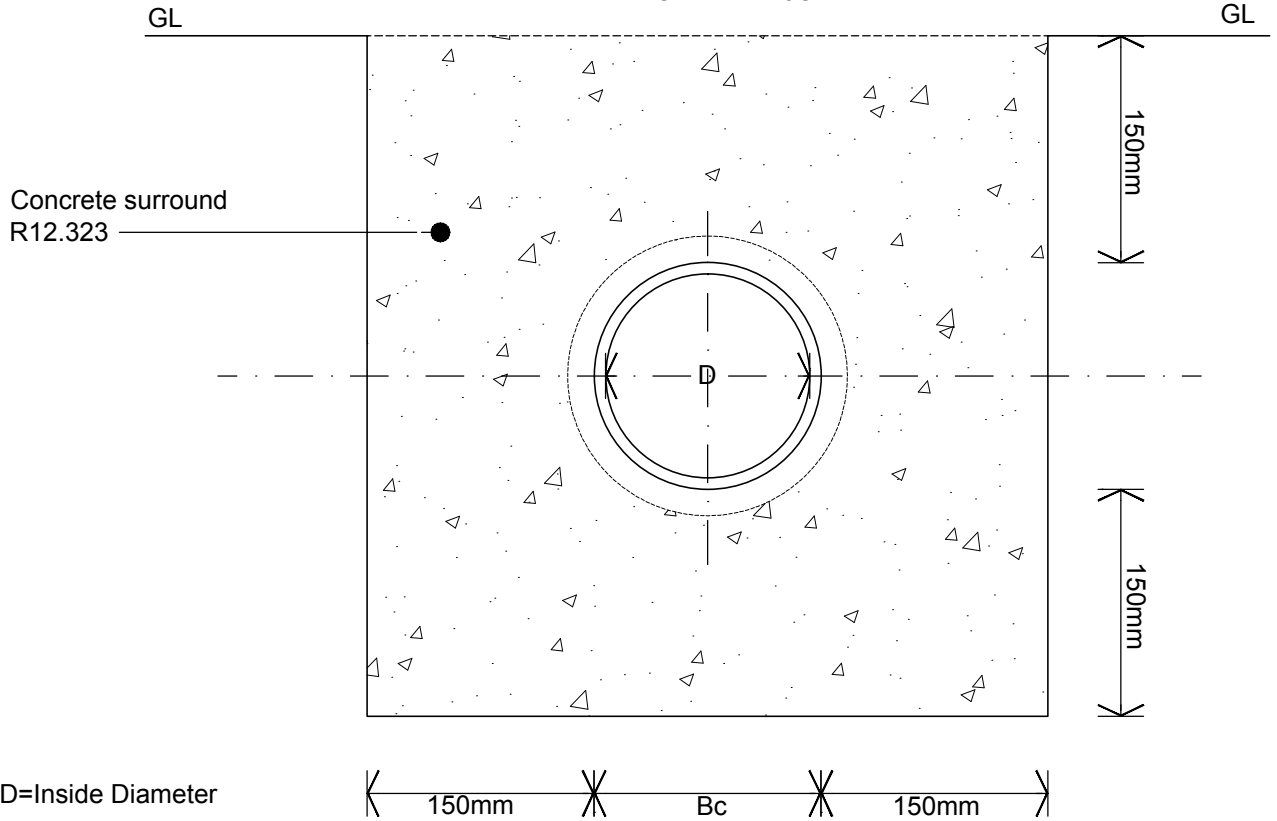
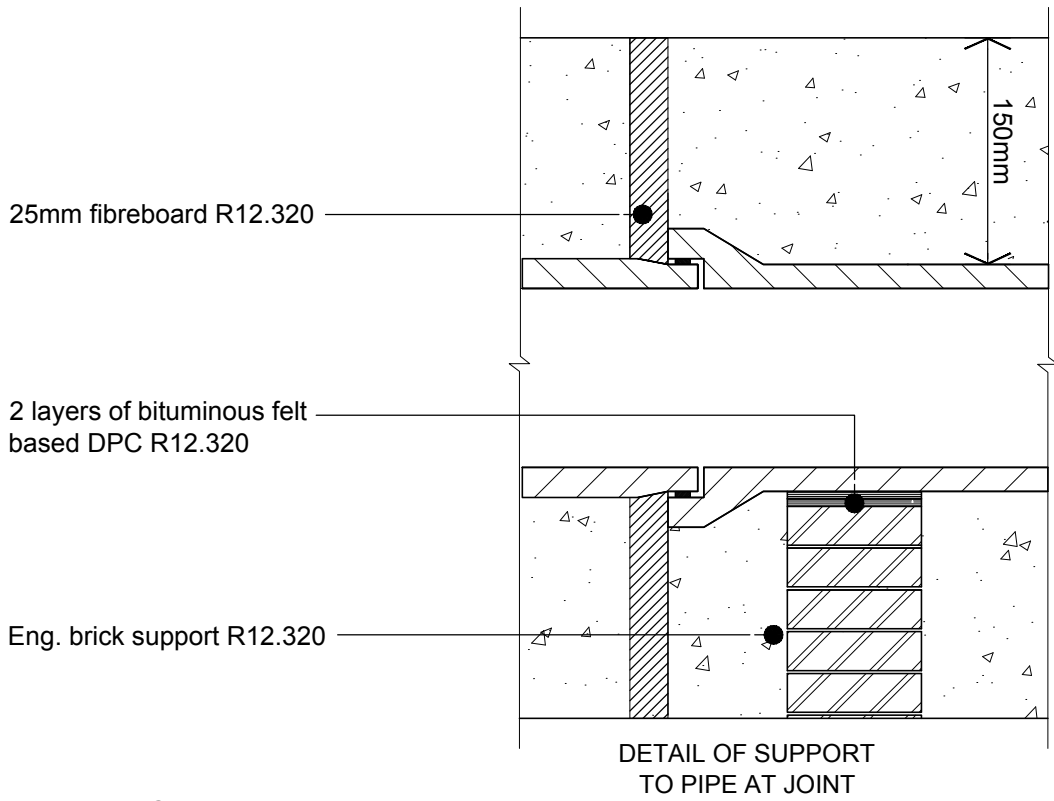

D=Inside Diameter

**NOTE:**

- If the diameter of the pipe is > 150mm then the dimension above the pipe would increase to the same thickness.
- Concrete surround also required if trench is in close proximity to foundations. See detail A(01.10)01.
- The BCNI Standards Panel endorsement only applies to drainage systems within the curtilage of a building, not those adopted by N.I. Water.

TITLE	CONCRETE SURROUND & JOINT DETAIL main foul/storm drainage for rigid pipes		
-------	---	--	--

DRAWN BY P&S	SCALE 1:5	DATE Aug 90
DRAWING NO.	A(08.14)12	
REV NO. & DATE	(3) 07/16	
REV NOTE: Updated for Building Control		





PRECAST CONCRETE CIRCULAR MANHOLE 3-6 M DEEP - NIW B

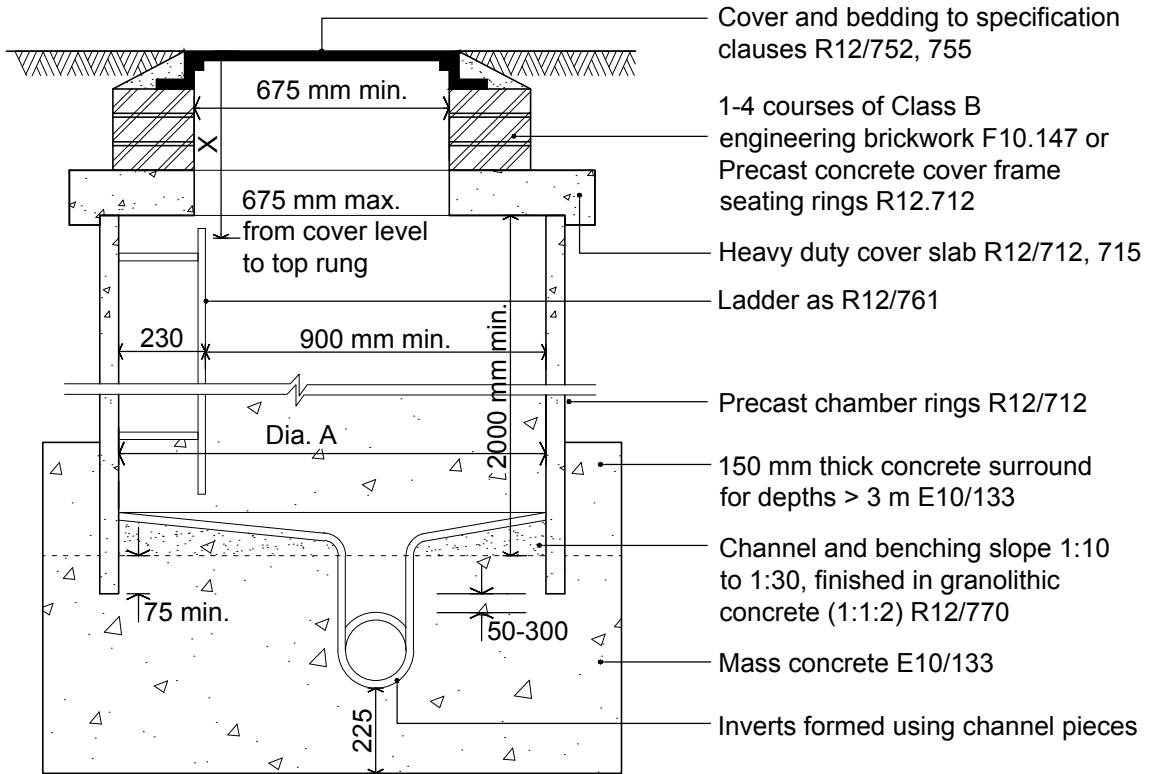

- Cover and bedding to specification clauses R12/752, 755
- 1-4 courses of Class B engineering brickwork F10.147 or Precast concrete cover frame seating rings R12.712
- Heavy duty cover slab R12/712, 715
- Ladder as R12/761
- Precast chamber rings R12/712
- 150 mm thick concrete surround for depths > 3 m E10/133
- Channel and benching slope 1:10 to 1:30, finished in granolithic concrete (1:1:2) R12/770
- Mass concrete E10/133
- Inverts formed using channel pieces

SECTION

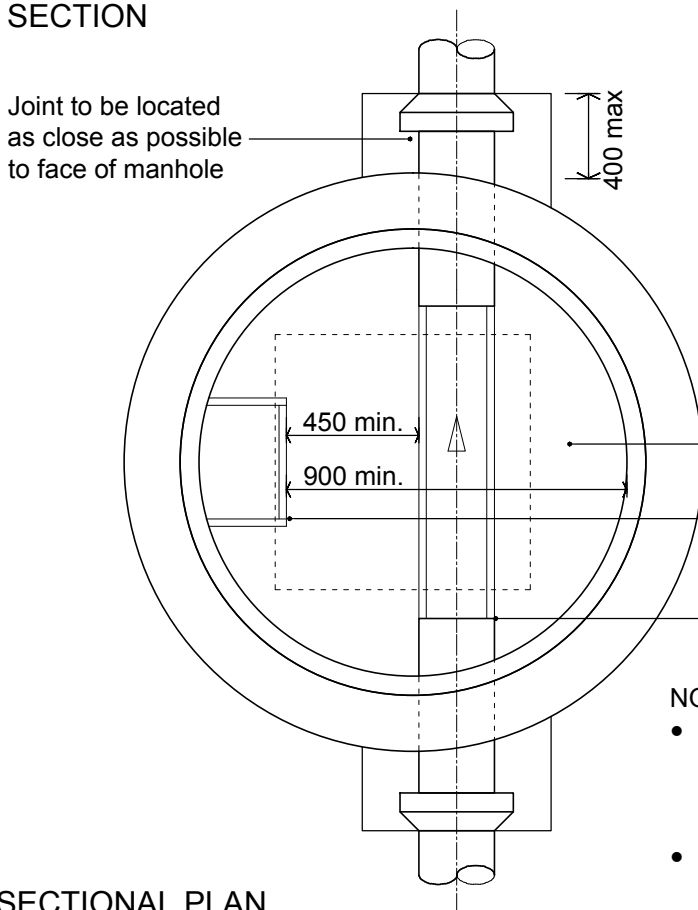

Pipe Diameter (mm)	Dimension A (mm)
Less than 375	1200
375 to 450	1350
500 to 700	1500

NOTES:

- In poor/aggressive ground conditions a full depth concrete surround is required and should be designed to BRE Special Digest 1 Concrete in Aggressive Ground
- Manholes with 1.5m diameter or more should incorporate a reducing slab as Northern Ireland Water Typical Manhole Detail - NIW C

SECTIONAL PLAN



TITLE TYPICAL MANHOLE - NIW B 3-6 m deep	DRAWN BY P&S	SCALE 1:20	DATE June 14
	DRAWING NO. A(08.14)13		
	REV NO. & DATE		
	REV NOTE:		



**SAMPLING CHAMBER**  
(maximum depth 1.0m)

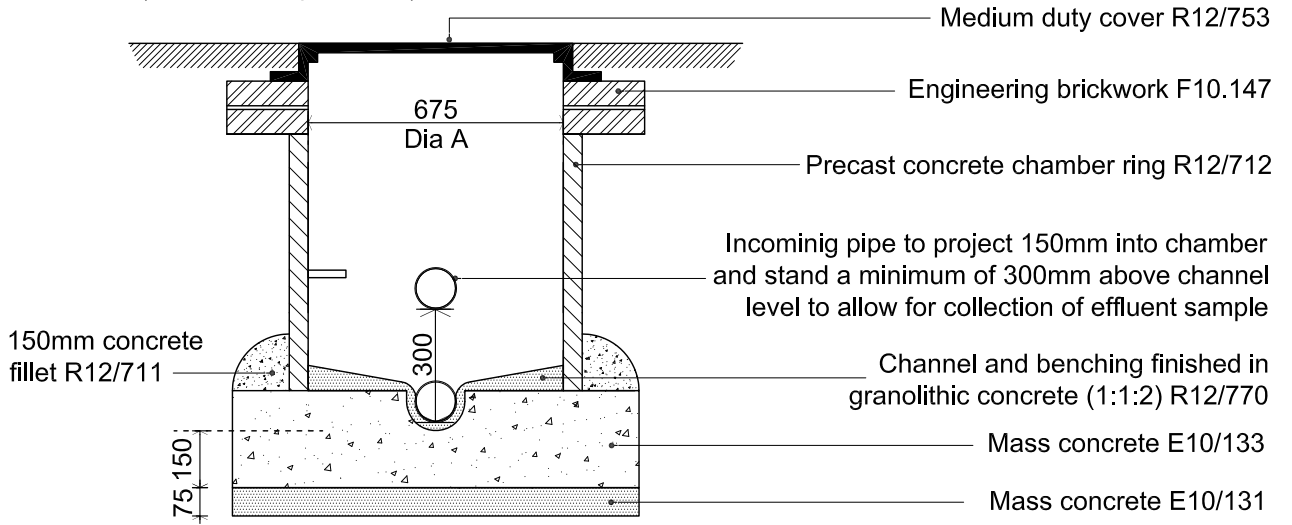

**SECTIONAL ELEVATION**

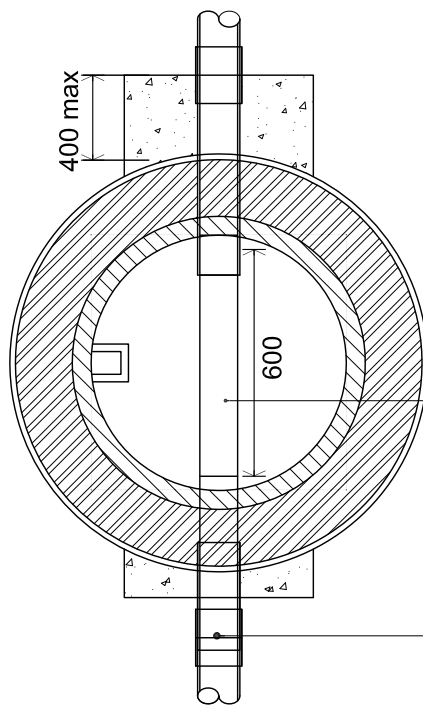

Pipe Diameter	Dimension A
100 mm	675mm

**SECTIONAL PLAN**

© NIHE 2015  
DRAWINGS NOT TO BE SCALED DUE TO PRINTING DISTORTION



<b>TITLE</b>  SAMPLING CHAMBER (max depth 1m)	<b>DRAWN BY</b> P&S	<b>SCALE</b> 1:20	<b>DATE</b> Jan 16
	<b>DRAWING NO.</b>	A(08.14)14	
	<b>REV NO. &amp; DATE</b>		
	<b>REV NOTE:</b>		

**SAMPLING CHAMBER**  
(maximum depth 1.4m)

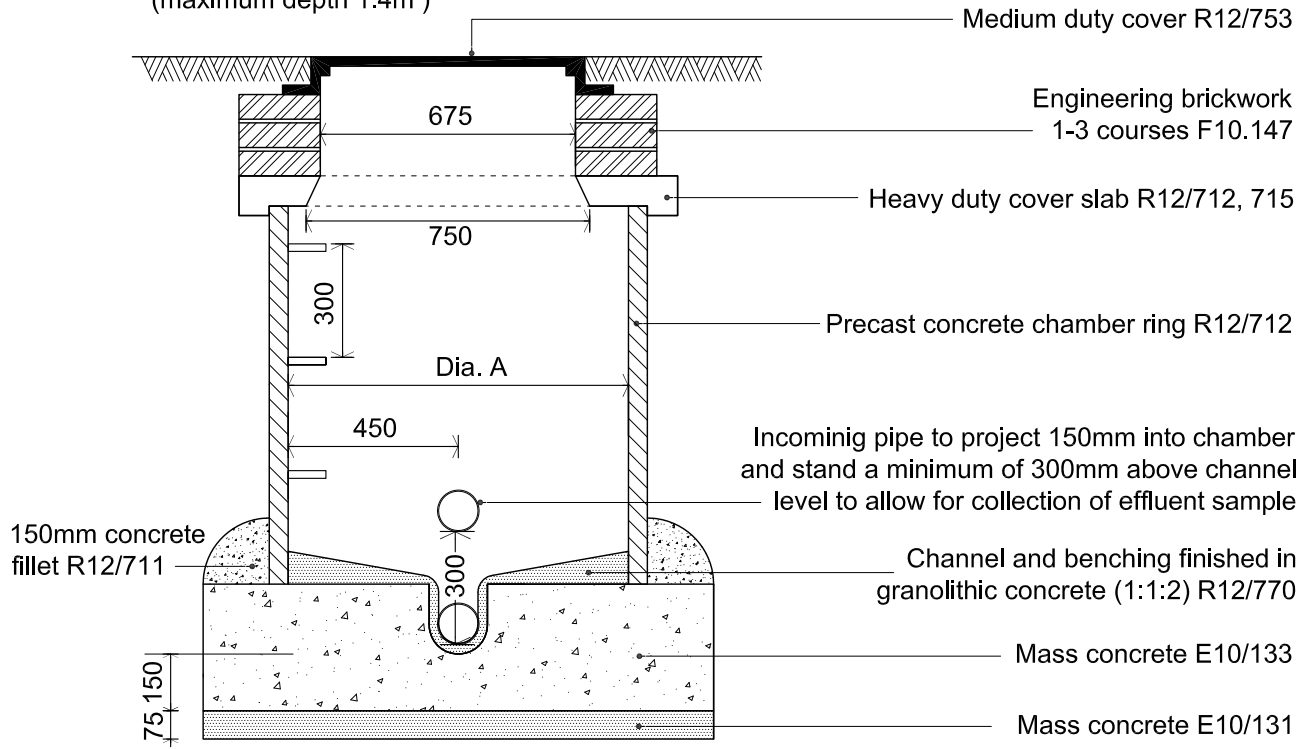

**SECTIONAL ELEVATION**

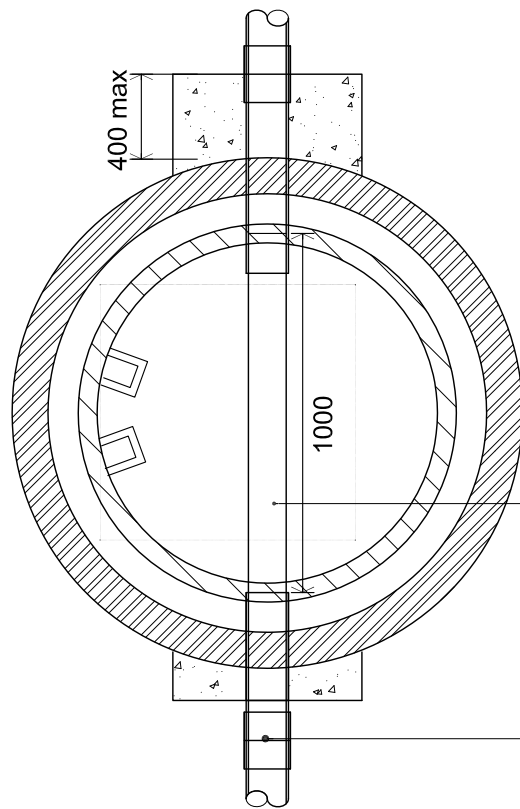

Pipe Diameter	Dimension A
100 mm	900mm

**SECTIONAL PLAN**



TITLE  
**SAMPLING CHAMBER**  
(max depth 1.4m)

DRAWN BY <b>P&amp;S</b>	SCALE <b>1:20</b>	DATE <b>Jan 16</b>
DRAWING NO.	<b>A(08.14)15</b>	
REV NO. & DATE		
REV NOTE:		



© NIHE 2015  
DRAWINGS NOT TO BE SCALED DUE TO PRINTING DISTORTION

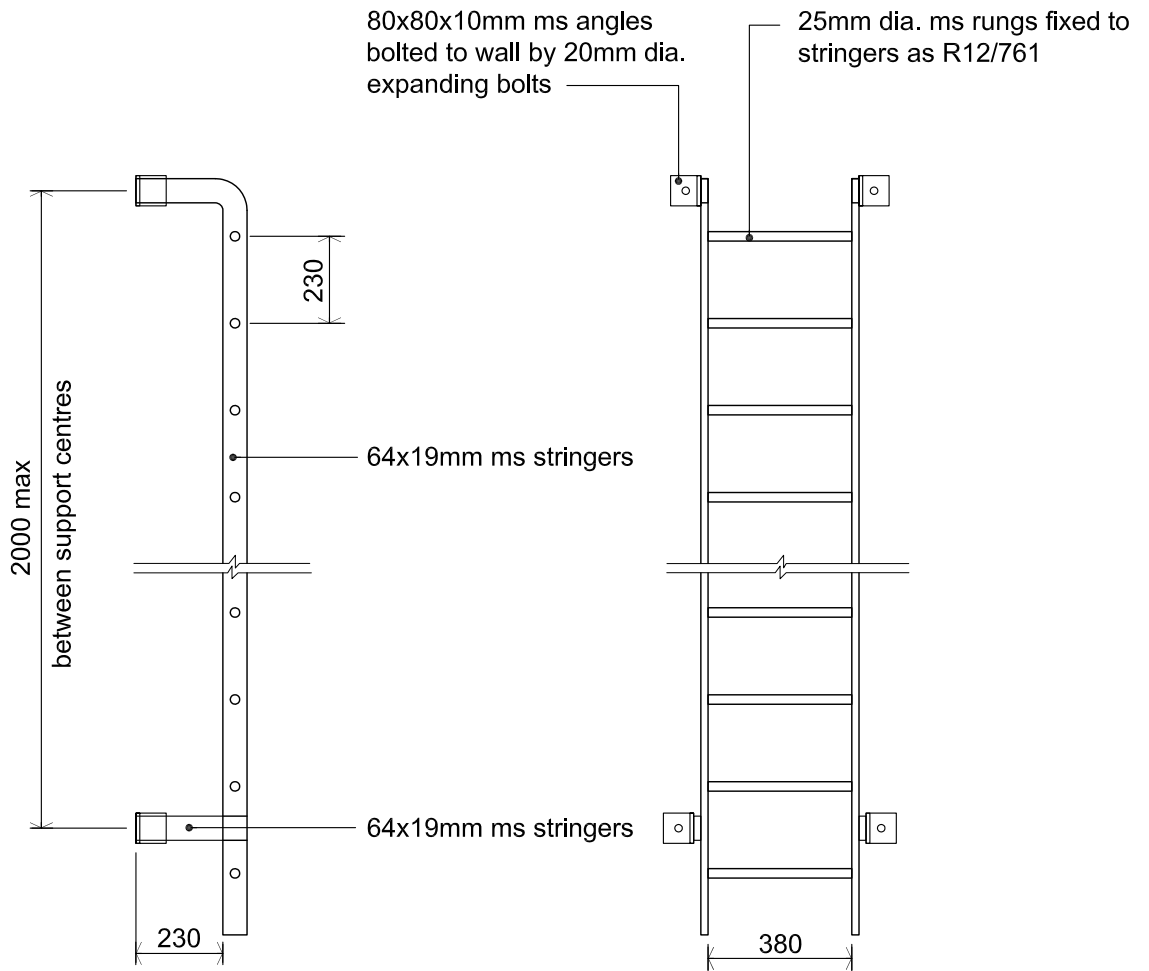

SECTION

ELEVATION

NOTE

All steelwork to be galvanised to Z11/360 with a surface coating of at least 600g/sq.m of surface area or a thickness of 80 microns.

SPECIFICATION REFERENCE R12/761



TITLE  MANHOLE LADDER	DRAWN BY LM/CB	SCALE 1:20	DATE Jul 91
	DRAWING NO.	C(08.14)01	
	REV NO. & DATE	(2) 10/12	
	REV NOTE: Updated to revised spec		

\* This NIHE produced detail has been examined by The Building Control N.I. Standards Panel and has been considered reasonable in its interpretation of the relevant requirements of the Building Regulation NI 2012. There is no legal obligation for any Building Control department to adopt this recommendation & it is subject to revision in the event of changes to the legislation or other mitigating circumstances.

**TANK SECTION**

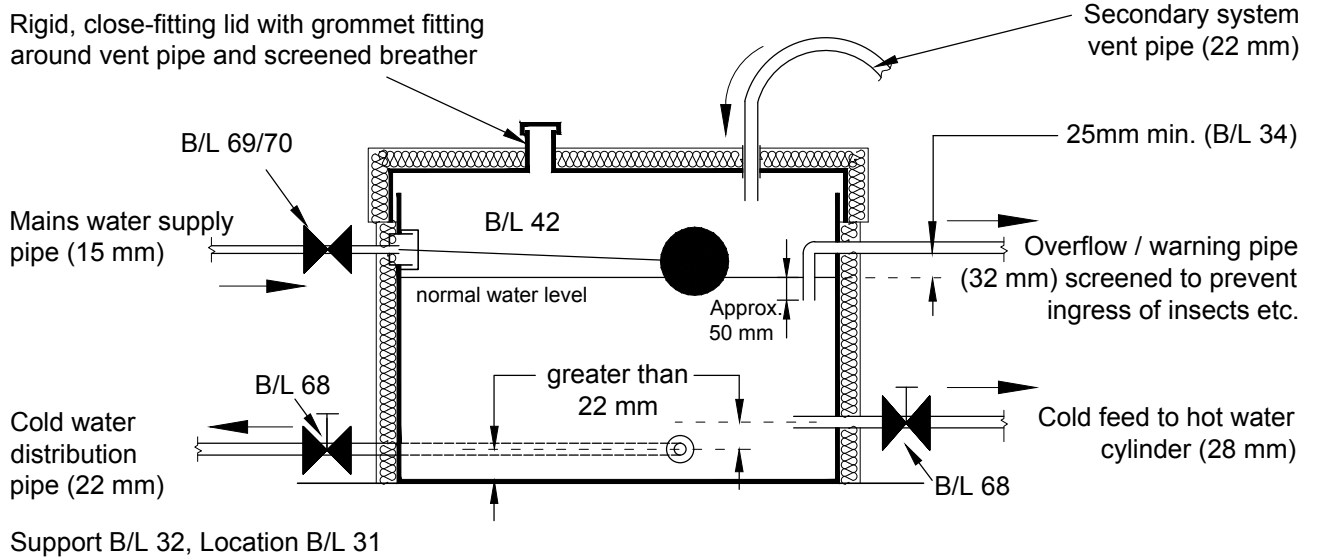

**RECTANGULAR TANK PLAN**

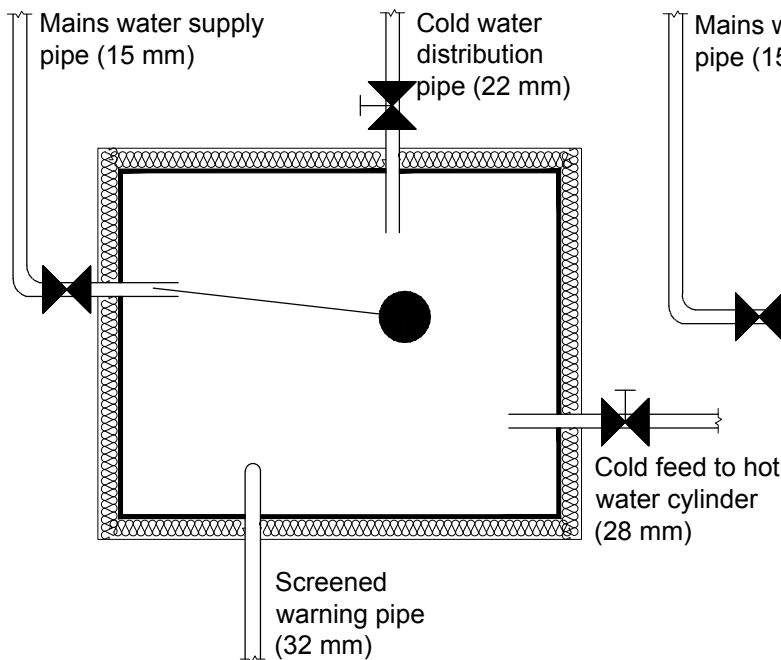

**CIRCULAR TANK PLAN**

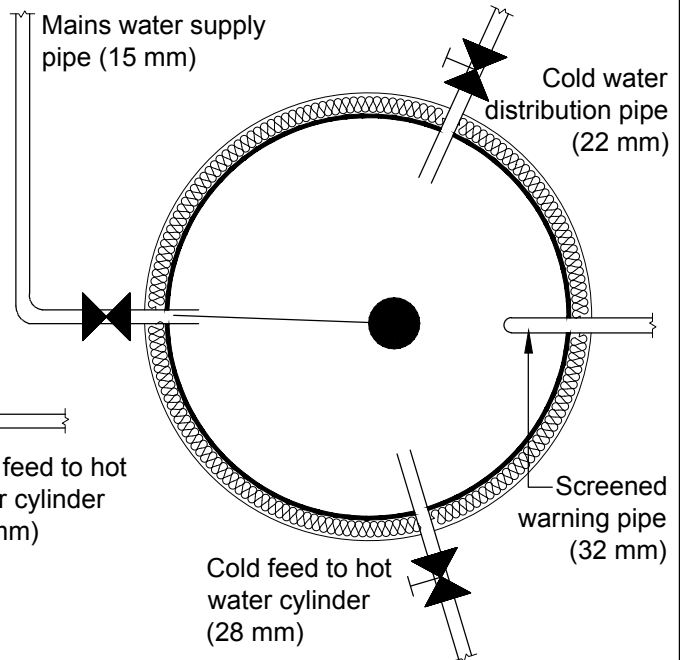

**KEY:**

B/L = BYELAW,



= GATE VALVE,



= SERVICE VALVE

**Notes:**

- The recommended height difference between the cold water distribution pipe and the feed to the hot water tank minimises the risk of scalding from outlets (such as showers) if the water supply fails
- Installation of cistern and pipework as Standard Specification Section S12- Hot and Cold Water.
- Water tanks should be insulated in accordance with NIHE Code of Practice P10 - Installation of Additional Roof Space Insulation, and securely fitted as clause S12.360.
- Insofar as possible the supply, feed and distribution pipes should be fitted at evenly spaced intervals around tank perimeter.
- Pipe insulation to comply with the Domestic home heating guide table 11 & BS 5422:2009

**Housing Executive**

*BCNI Standards Panel Agreed \**

TITLE	STORAGE CISTERN ROUND & SQUARE TANK B/L 30		
-------	--	--	--

DRAWN BY	SCALE	DATE
P&S	N.T.S.	FEB 96
DRAWING NO.	A(09.10)03	
REV NO. & DATE	(2) 07/14	
REV NOTE:	Circular tank option added	





L.P.G. TYPICAL WORK ARRANGEMENT  
FOR I.P.B.S. SCHEME

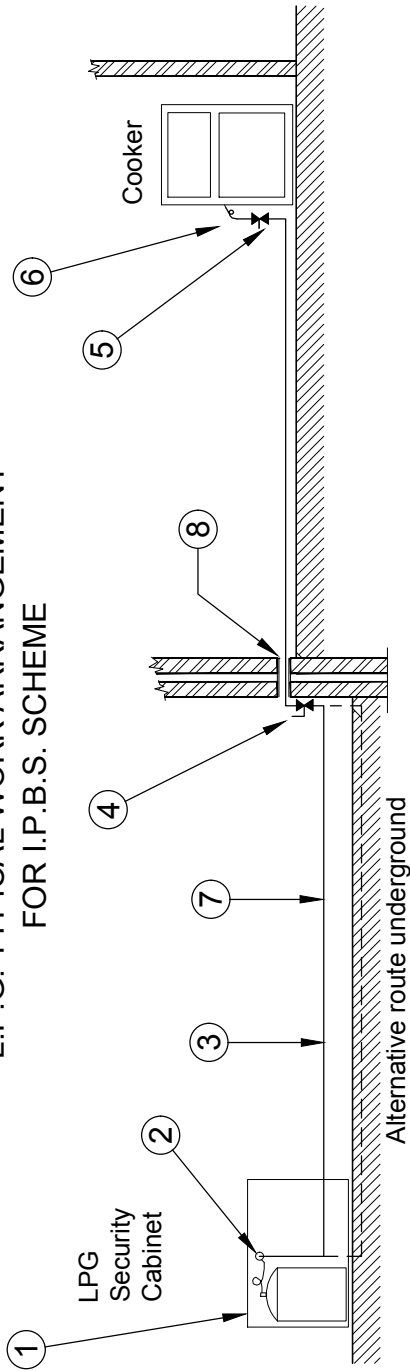

1. SECURITY CABINET AS S33/630 AND DRAWING NO. A(09.10)12
2. PROPANE HIGH PRESSURE REGULATOR (SINGLE STAGE) S33/628
3. COPPER PIPE S33/620
4. EMERGENCY CONTROL VALVE S33/625
5. APPLIANCE SHUT OFF VALVE S33/626
6. QUICK FIX HOSE S33/627
7. GUARD FOR PIPEWORK S33/622
8. SLEEVE FOR PIPEWORK S33/620

Notes:-

When installing LPG gas appliances and bottles the manufactures' instructions must be adhered to at all times.  
All work on LPG installations must be carried out by a registered Gas Safe installer.  
Gas installation as S33/635 and S33/640  
LPG pipes shall be cross bonded in accordance with IET Wiring Regulations.  
All copper pipework shall be 15mm plastic covered and colour coded yellow ochre.  
All testing and purging shall be carried out all as per S33/642.  
The installer shall, on completion, provide a landlords' Gas Safety Record (CP12) certificate that the installation has been completed and tested in accordance with BS 5482-1:2005 as S33/642

TITLE	DRAWN BY	SCALE	DATE
LPG TYPICAL WORK ARRANGEMENT FOR COOKER INSTALLATIONS	RG/CB	NTS	OCT 96
	DRAWING NO.	A(09.10)11	
	REV NO. & DATE	(4) 08/16	
	REV NOTE:	Note removed	

REV NOTE:		
Note removed		
DRAWING NO.		
A(09.10)11		
REV NO. & DATE		
(4) 08/16		
SCALE		
NTS		
DRAWN BY		
RG/CB		
DATE		
OCT 96		

**NOTES:**

- Cabinet to be sufficiently robust construction, to be theft & vandal resistant, and to stand up to loading and unloading heavy gas bottles.
- All mild steel and expanded metal vents to be galvanised.
- All nuts, bolts, screws, rivets, etc, used in construction, to be galvanised or non-rust.

**Outline Sketch of Security Cabinet  
For Domestic Gas Bottles**

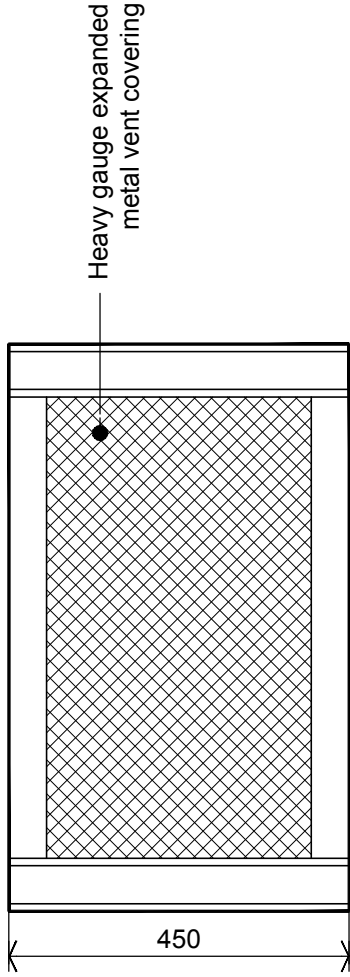

**BTM. ELEVATION**

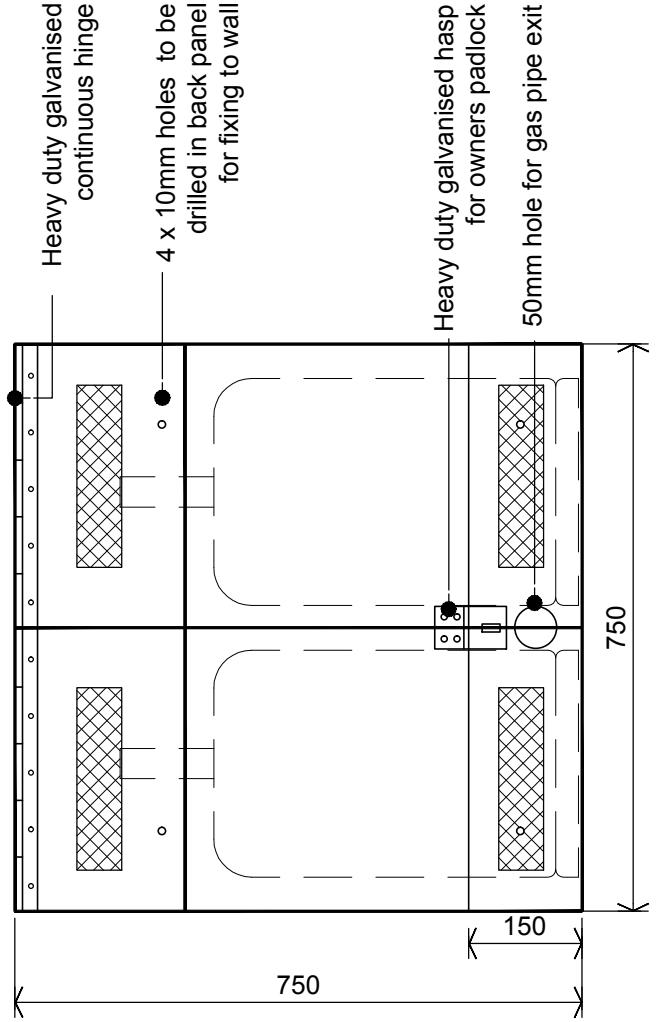

**FRONT ELEVATION**

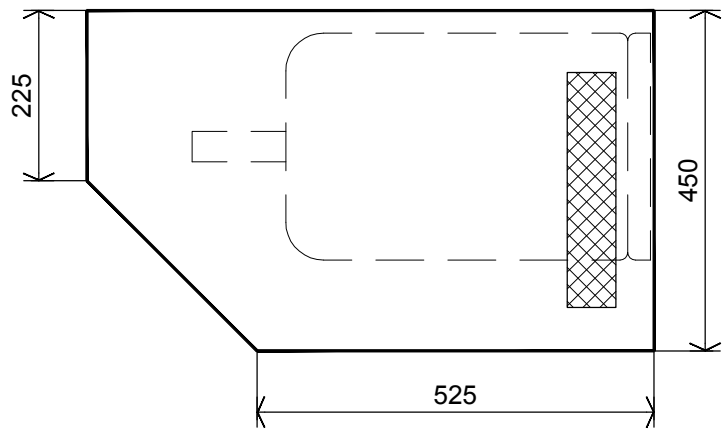

**SIDE ELEVATION**



TITLE

Outline Sketch of  
Security Cabinet for  
Domestic Gas Bottles

DRAWN BY

P&S

SCALE

1:10

DATE

08/16

DRAWING NO.

A(09.10)12

REV NO. & DATE

(1) 09/16

REV NOTE:

Notes amended





**NOTES:**

- All tanks should be at least 1.8m from a building & not closer than 760mm to any boundary, in accordance with BS 5410-1. Otherwise, provide a fire wall in accordance with CPI specification B10.011.
- Where tanks are installed in exposed conditions restraining straps should be used.
- Where the oil tank sits below the level of the boiler, a deaerated device should be installed.
- Deaerated device to be fitted no closer than 500mm to a flue.
- Deaerated device must be installed upright, and flow and return pipes clearly marked.

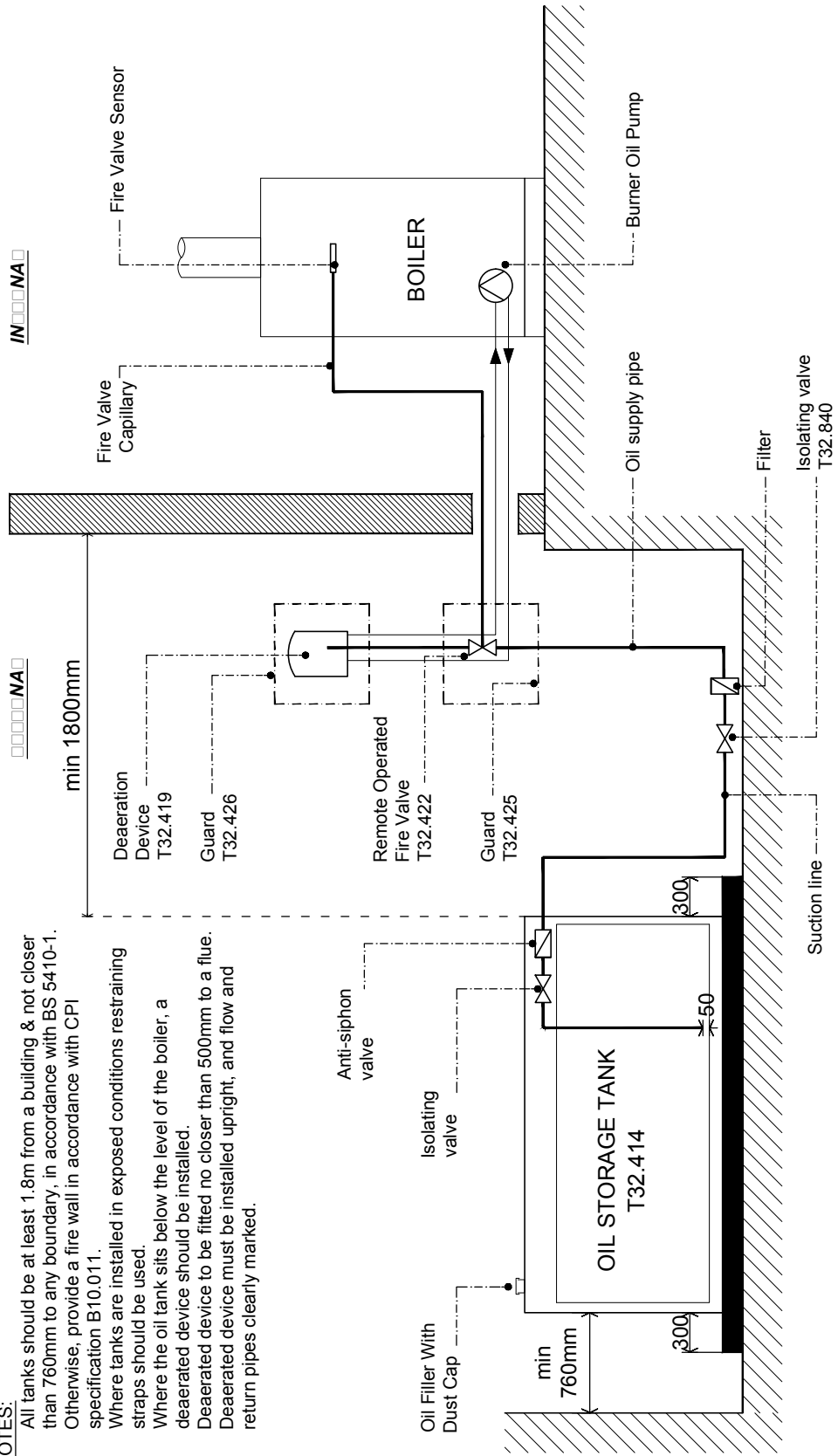

TITLE

**OIL SUPPLY**  
Single Pipe With  
Deaeration Device

DRAWN BY  
**P&S**

SCALE  
**N.T.S.**

DATE  
**Dec. 97**

DRAWING NO.

**A(09.10)15**

REV NO. & DATE

**(4) 08/16**

REV NOTE:

**Updated Notes**





\* This NIHE produced detail has been examined by The Building Control N.I. Standards Panel and has been considered reasonable in its interpretation of the relevant requirements of the Building Regulation NI 2012. There is no legal obligation for any Building Control department to adopt this recommendation & it is subject to revision in the event of changes to the legislation or other mitigating circumstances.

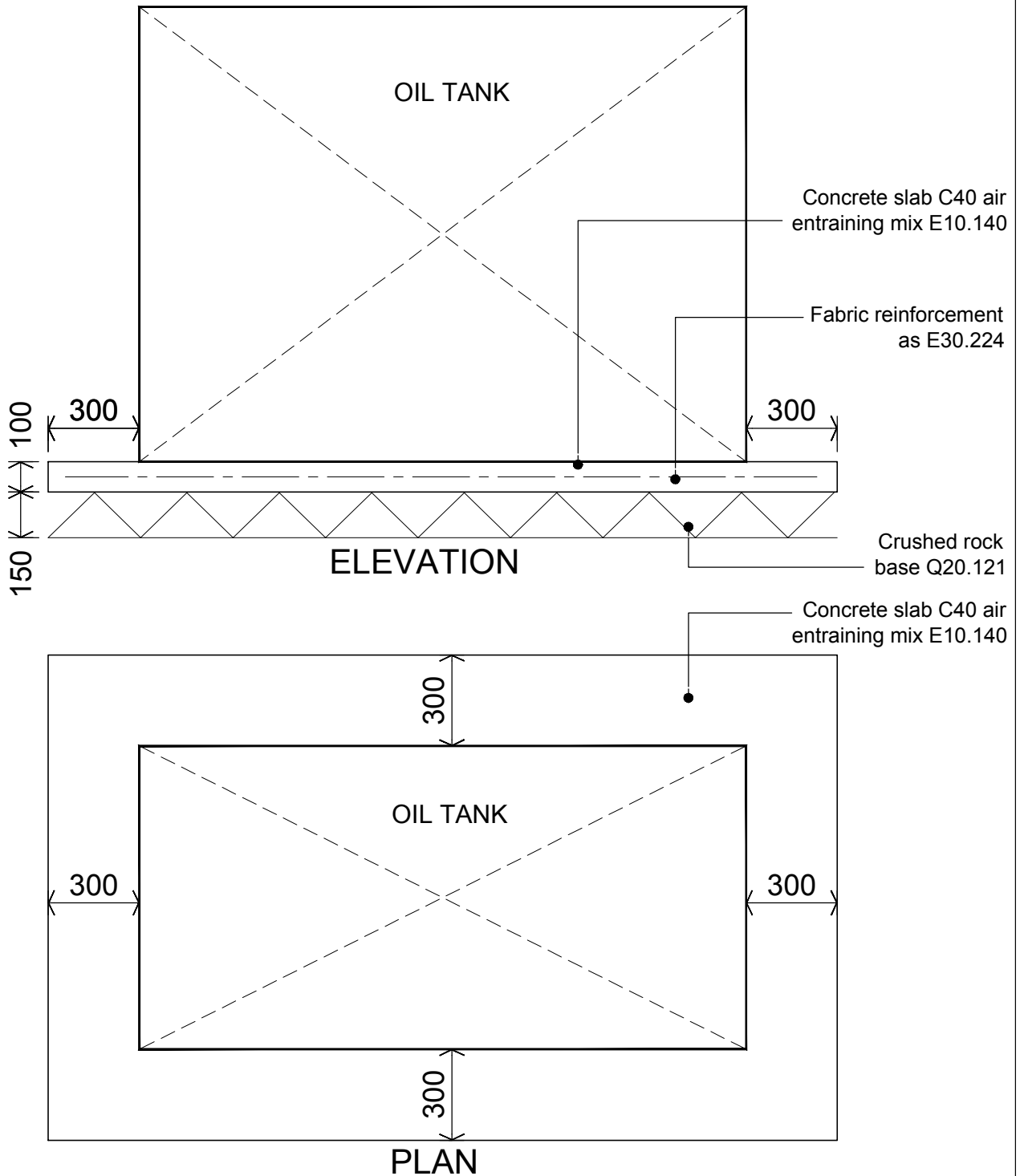

**NOTES:**

- Size of support slab will vary depending upon size & shape of oil tank.
- Support slab should extend 300mm min. beyond the perimeter of the tanks external skin.
- Fire protection measures to be applied in accordance with Spec clause B10.011.
- Fuel pipework should be protected in accordance with BS5410-1:1997 Sections 8.2 & 8.3.
- An oil storage tank should be constructed in accordance with OFS T100: 2008 for polyethylene oil storage tanks or OFS T200: 2010 for steel oil storage tanks.
- The oil should be stored in an integrally bunded prefabricated tank.
- The bund should have a capacity of not less than 110% of the tank it contains.

**Housing Executive**

**BCNI Standards Panel Agreed \***

TITLE  
OIL STORAGE TANK  
SUPPORT SLAB  
Single family dwellings

DRAWN BY <b>P&amp;S</b>	SCALE 1:20	DATE Nov. 96
DRAWING NO.	A(09.10)18	
REV NO. & DATE	(2) 09/14	
REV NOTE: Notes & Spec clause added		



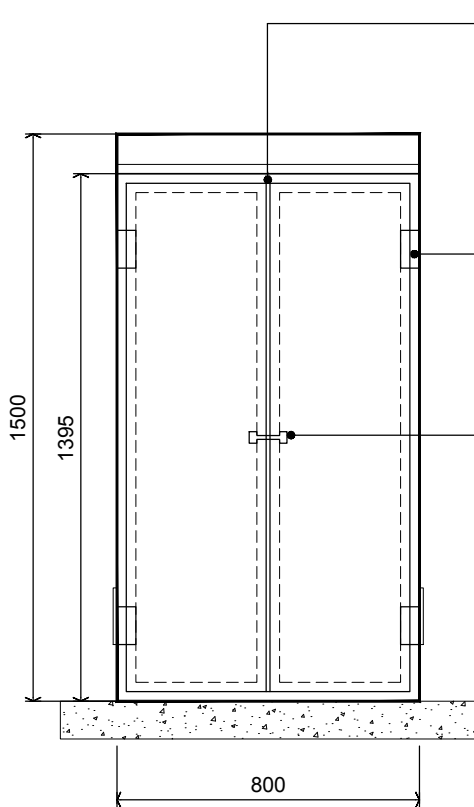

FRONT VIEW

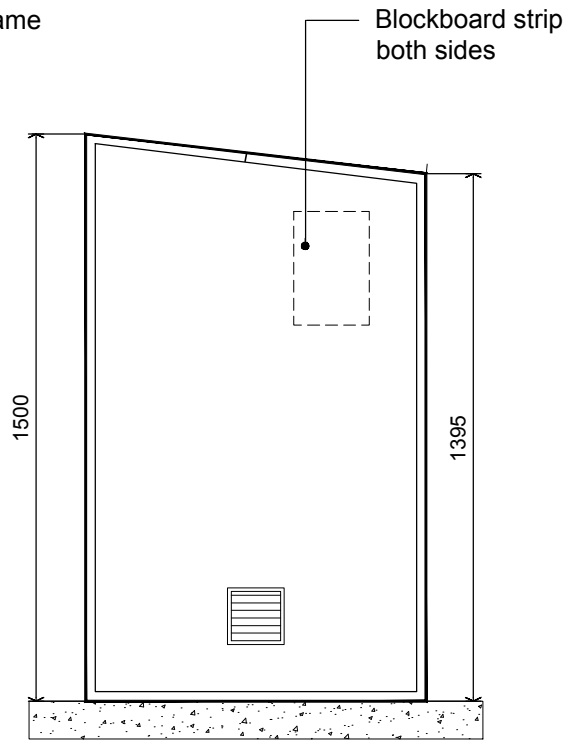

SIDE VIEW

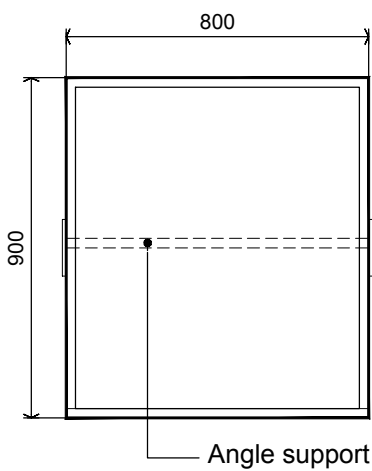

PLAN VIEW

NOTES:

- Roof, back and sides to be insulated with 25mm thick foiled backed fibreglass.
- Hasp and Staple to be fitted to doors.
- Split doors for easy access.
- Earth bond to be fitted
- Anchor points for floor or wall fixing.
- Mounting boards for electrical equipment.
- Internal light fitting and switch.
- Flue exit to suit boiler.
- Weathering strip fixed to roof above doors.
- Flap fitted to doors.
- Ventilators to be fitted to both sides.
- FOR SPECIFICATION SEE B10/010

© NIHE 2017 DRAWINGS NOT TO BE SCALED DUE TO PRINTING DISTORTION



TITLE  <b>BOILER HOUSE</b>	DRAWN BY <b>R.G.</b>	SCALE <b>1:20</b>	DATE <b>Nov.98</b>
	DRAWING NO. <b>A(09.10)48</b>		
	REV NO. & DATE		
	REV NOTE:		



\* This NIHE produced detail has been examined by The Building Control N.I. Standards Panel and has been considered reasonable in its interpretation of the relevant requirements of the Building Regulation NI 2012. There is no legal obligation for any Building Control department to adopt this recommendation & it is subject to revision in the event of changes to the legislation or other mitigating circumstances.

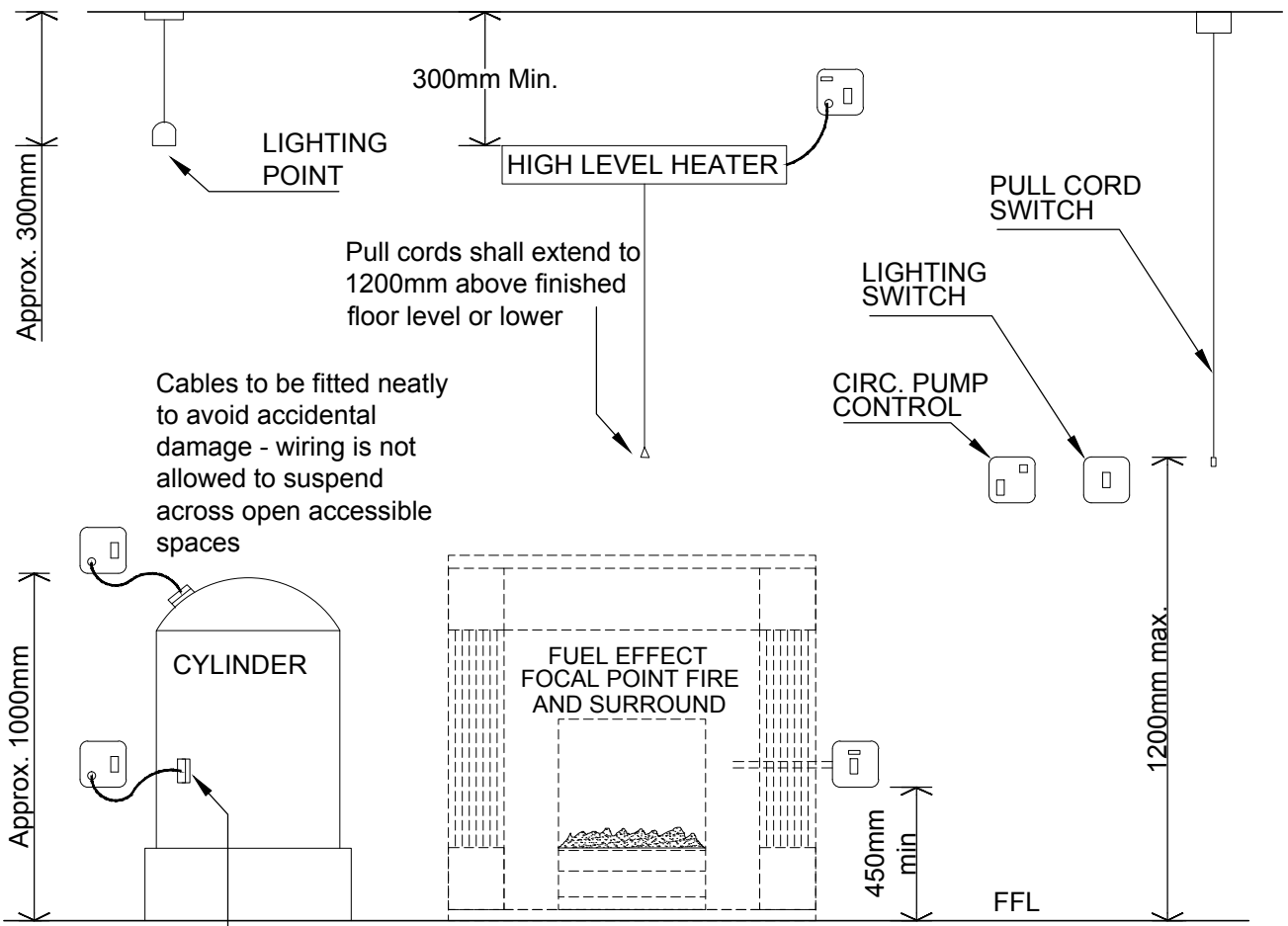

Hot Press thermostat to be positioned to be easy readable from access area

NOTE: All wall sockets and switches shall be located between 450mm and 1200mm above finished floor level and be aligned and level with each other throughout the room.

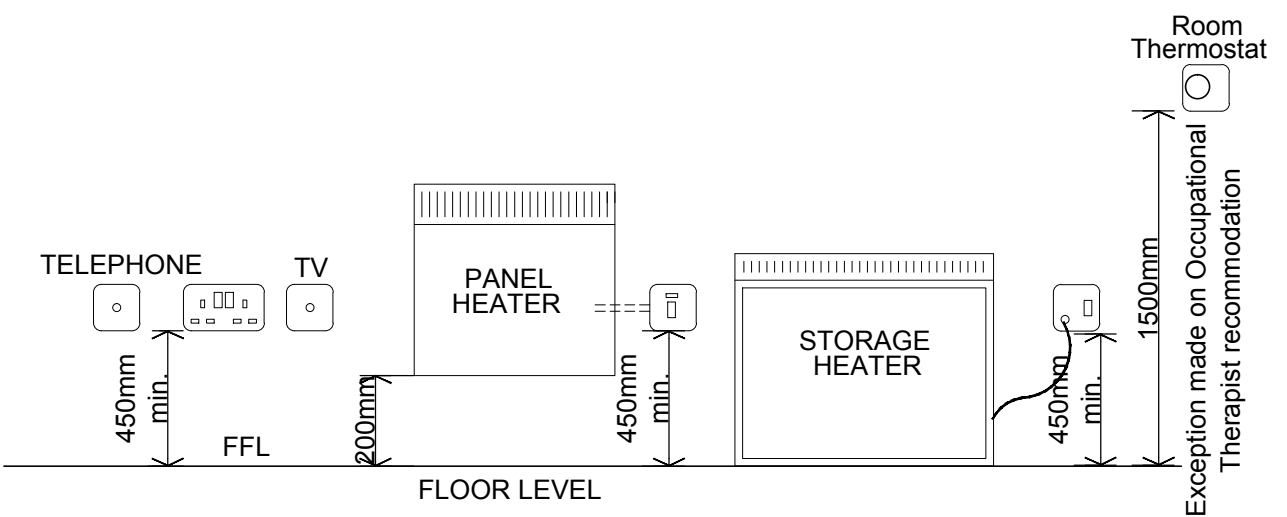

Specification References V51/644, 790, V90/584



TITLE  
DOMESTIC ELECTRICAL  
EQUIPMENT AND  
ACCESSORIES  
MOUNTING HEIGHTS

DRAWN BY P&S	SCALE NTS	DATE Mar 01
DRAWING NO.	A(09.16)10	
REV NO. & DATE	(5) 08/16	
REV NOTE: Room stat. height amended		

© NIHE 2017  
DRAWINGS NOT TO BE SCALED DUE TO PRINTING DISTORTION



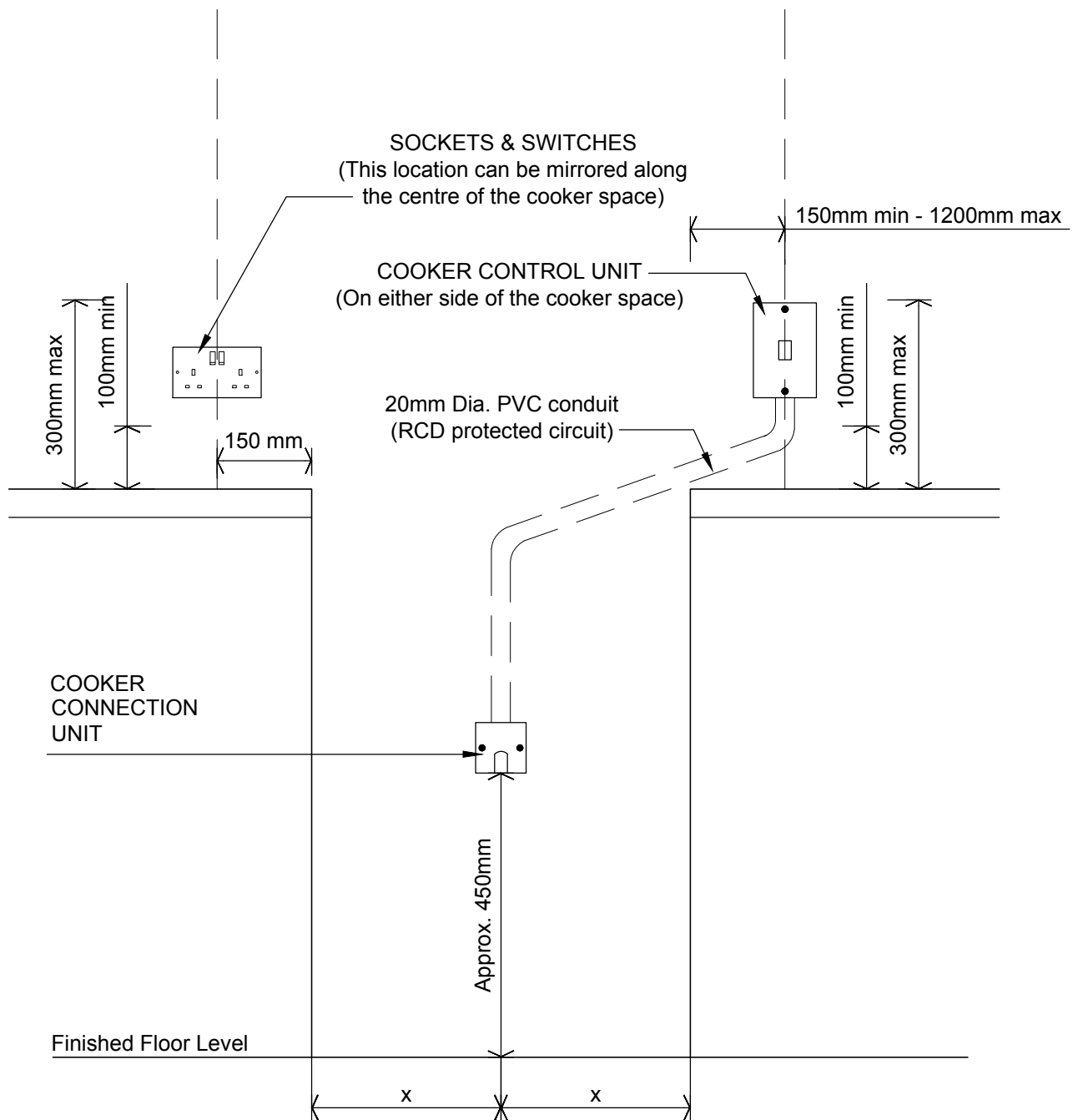

**NOTES:**

The cooker control unit shall be:

- Positioned vertically no less than 100mm and no more than 300mm above worktop level.
- Positioned horizontally within 150-1200mm from the edge of the cooker space.
- Positioned to avoid unnecessary cutting of wall tiles and areas that are difficult to grout.
- Aligned so that the bottom of the control switch is level with the bottom of other sockets and switches throughout the room.

Specification References V90/584, V90/644



TITLE	Cooker Control Unit, Sockets Connection Unit & Arrangement Adjustment to Cooker		
-------	---	--	--

DRAWN BY <b>P&amp;S</b>	SCALE <b>NTS</b>	DATE <b>Mar. 01</b>
DRAWING NO.	<b>A(09.16)12</b>	
REV NO. & DATE	<b>(6) 09/14</b>	
REV NOTE: Sockets added, distances & spec ref. amended		



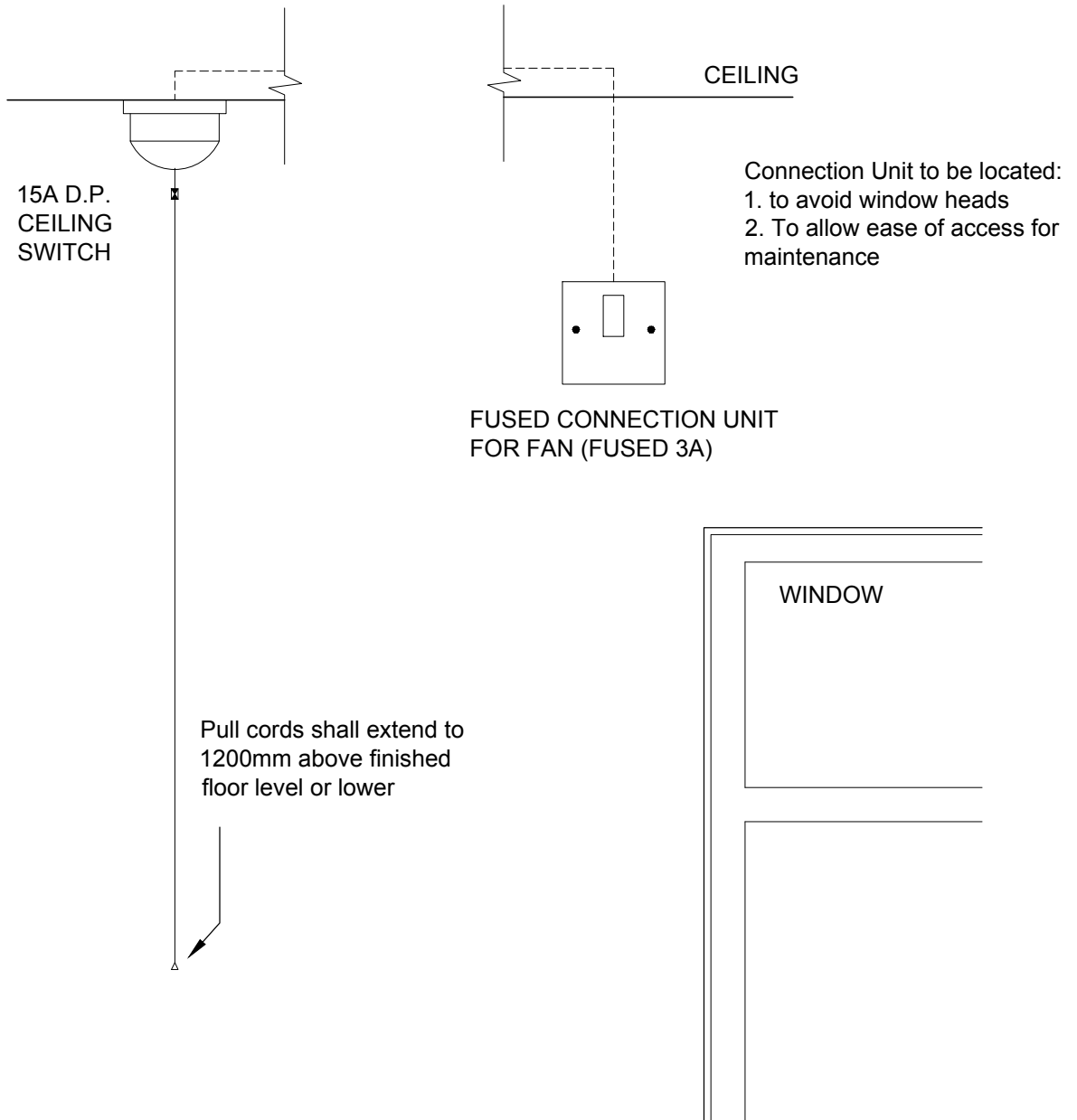

**NOTES:**

1. Bathroom fan wired from lighting circuit on same floor.
2. Pull cord shall extend to 1200mm above finished floor level or lower.
3. See Standard Detail No. A(05.13)02 for builders work required to duct extract through wall.

Specification References V90/584, V90/815, V51/644

© NIHE 2017 DRAWINGS NOT TO BE SCALED DUE TO PRINTING DISTORTION

	<b>TITLE</b>  BATHROOM EXTRACT FAN INSTALLATION	<b>DRAWN BY</b> SA/CB	<b>SCALE</b> NTS	<b>DATE</b> Mar. 01	
		<b>DRAWING NO.</b> A(09.16)14		<b>REV NO. &amp; DATE</b> (4) 04/13	
		<b>REV NOTE:</b> Connection unit note added			

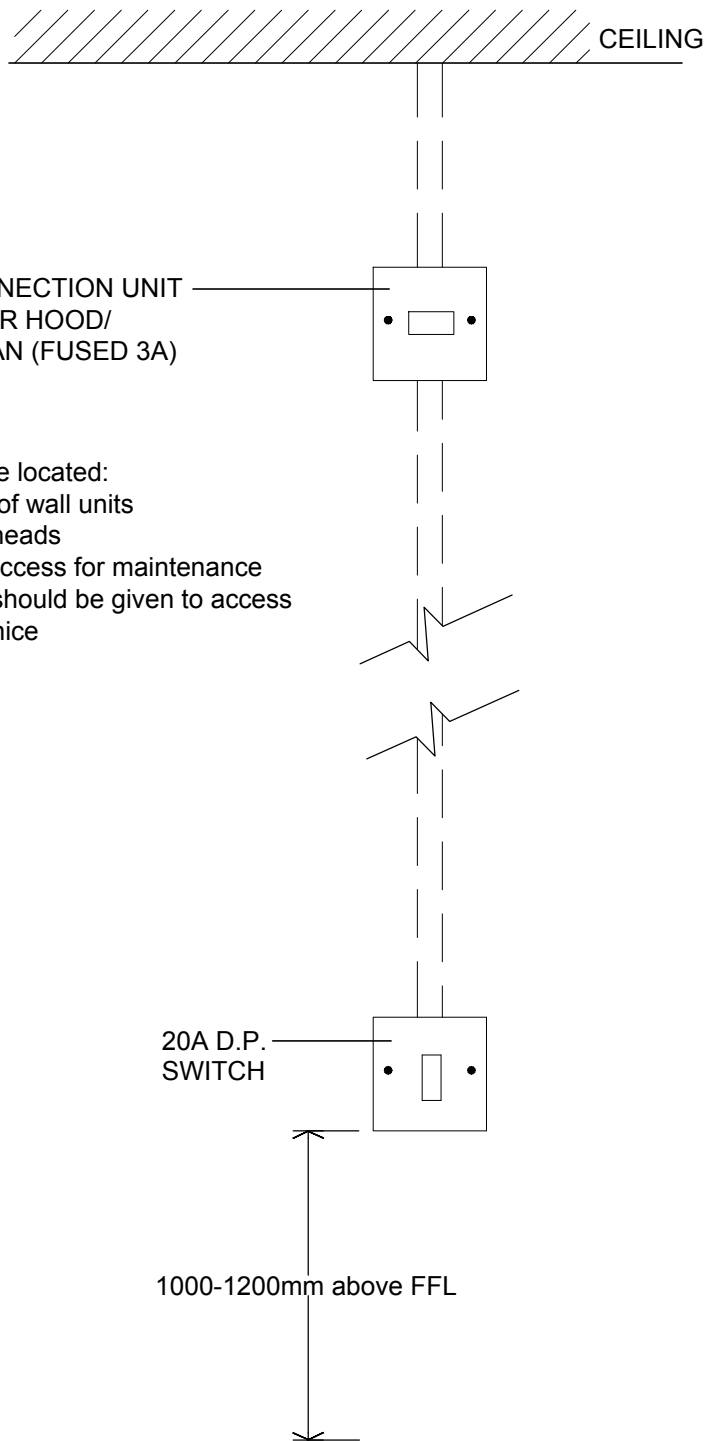

FUSED CONNECTION UNIT  
FOR COOKER HOOD/  
EXTRACT FAN (FUSED 3A)

Connection Unit to be located:

1. Above the height of wall units
2. To avoid window heads
3. To allow ease of access for maintenance

Note; consideration should be given to access unit past kitchen cornice

20A D.P.  
SWITCH

1000-1200mm above FFL

**NOTES:**

1. Kitchen cooker hood/extract fan wired from dedicated electrical circuit.
2. All wall sockets and switches shall be located between 450mm and 1200mm above finished floor level and be aligned and level with each other throughout the room.
3. See Standard Detail No. A(05.13)02 for builders work required to duct extract through wall.

Specification References V90/584, 810, 822

© NIHE 2017  
DRAWINGS NOT TO BE SCALED DUE TO PRINTING DISTORTION



<b>TITLE</b>  KITCHEN EXTRACT FAN INSTALLATION	<b>DRAWN BY</b> REG/CB	<b>SCALE</b> NTS	<b>DATE</b> 18/10/93
	<b>DRAWING NO.</b> A(09.16)15		
	<b>REV NO. &amp; DATE</b> (3) 04/13		
	<b>REV NOTE:</b> Connection unit note added		

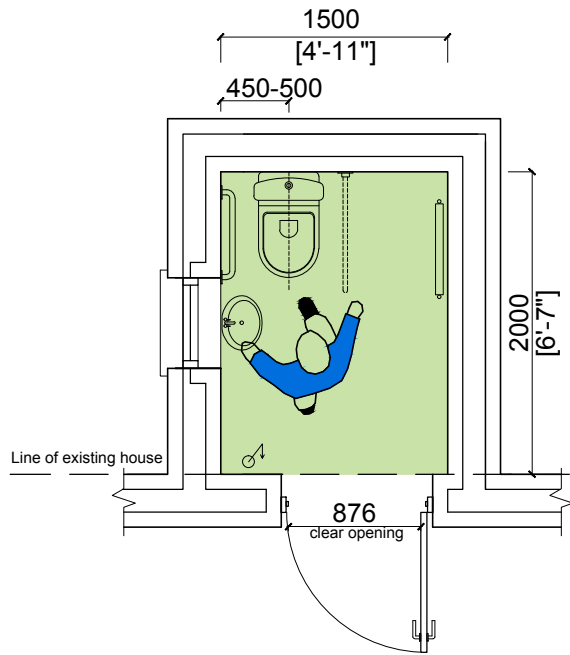

1A(i): Ambulant User -  
Walking Aid/ Assistance  
WC (3.00m<sup>2</sup>)

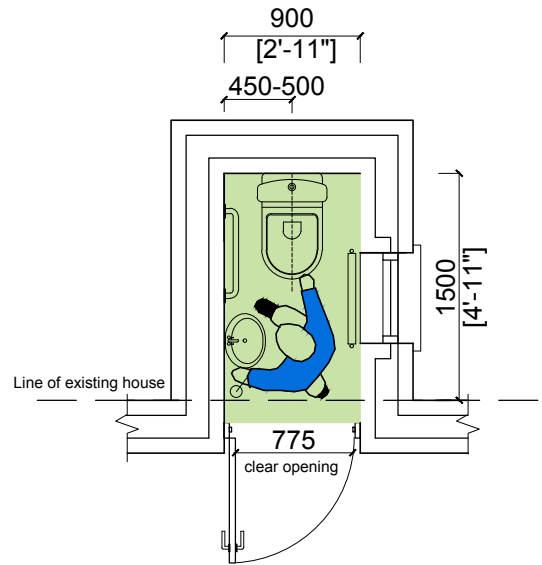

1A(ii): Ambulant User - Without  
Walking Aid WC (1.35m<sup>2</sup>)

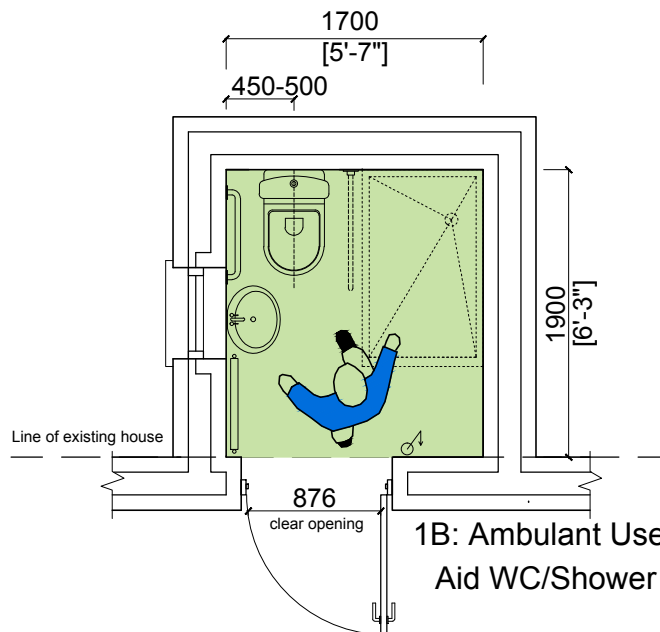

1B: Ambulant User - Walking  
Aid WC/Shower (3.23m<sup>2</sup>)

KEY:

WC / Shower -



TITLE  
Design Templates  
1A(i), 1A(ii) and 1B  
  
Ambulant User With /  
Without Walking Aid WC  
& WC / Shower

DRAWN BY P&S	SCALE 1:50	DATE Feb 2015
DRAWING NO.	A(10.10)01	
REV NO. & DATE	Rev 1 Nov 2016	
REV NOTE:	Updated clear opening door width	



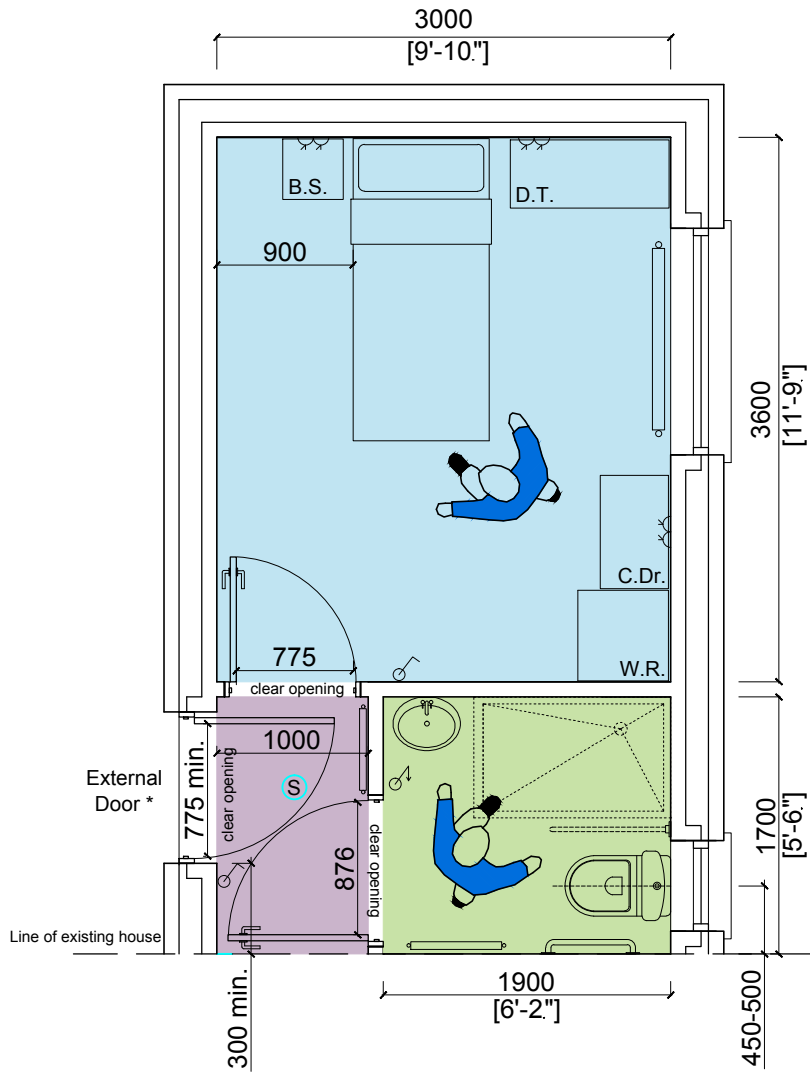

**KEY:**

- Smoke Alarm - (S)
- Bedroom - [Blue Box]
- Bathroom - [Green Box]
- Hallway - [Purple Box]

\* Level access to be provided at rear external door when requested by O.T., unless prohibited by site constraints or provided elsewhere.



<b>TITLE</b> Design Template 1C  Ambulant User - Walking Aid Single Standard Bedroom (10.80 m <sup>2</sup> )	<b>DRAWN BY</b> P&S	<b>SCALE</b> 1:50	<b>DATE</b> Feb 2015
	<b>DRAWING NO.</b>	A(10.10)02	
	<b>REV NO. &amp; DATE</b>	Rev 1 Nov 2016	
	<b>REV NOTE:</b> Updated clear opening door width		

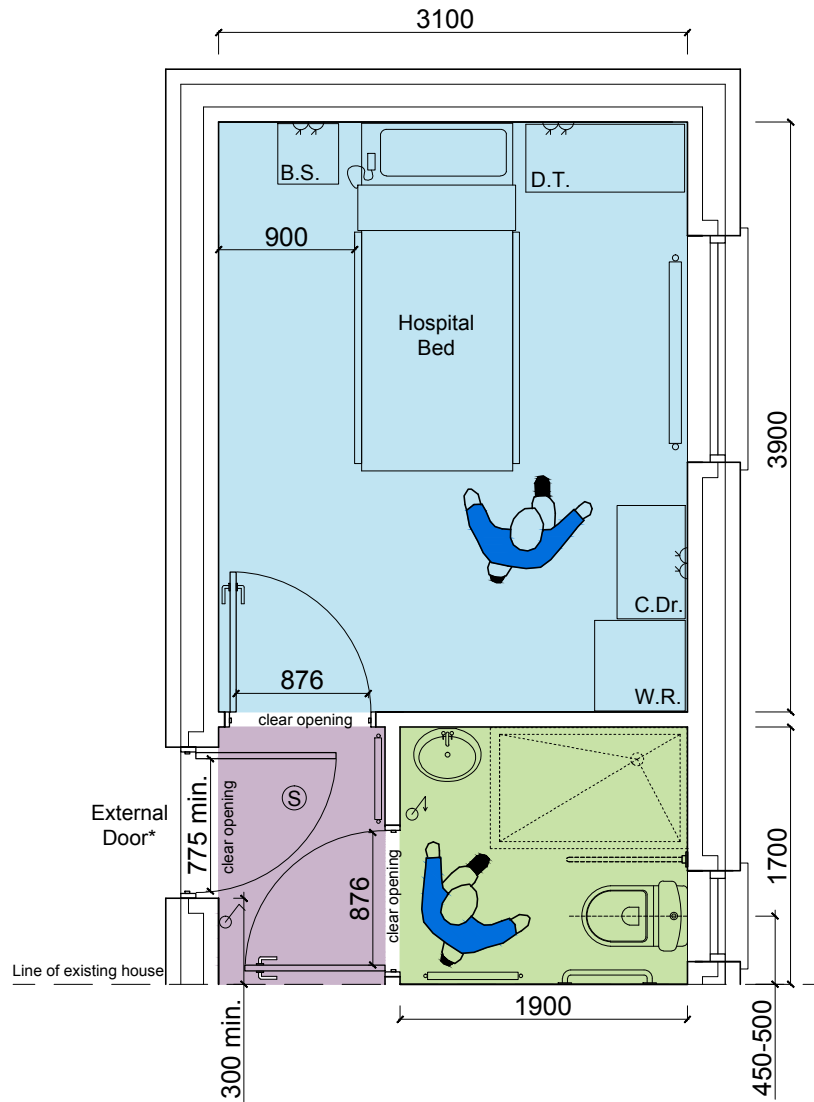

**KEY:**

- Smoke Alarm - (S)
- Bedroom - [Blue Box]
- Bathroom - [Green Box]
- Hallway - [Purple Box]

\* Level access to be provided at rear external door when requested by O.T., unless prohibited by site constraints or provided elsewhere.

	TITLE	DRAWN BY	SCALE	DATE
	Design Template 1D	P&S	1:50	Feb 2015
	Ambulant User - Walking Aid Single Standard Bedroom with Hospital Bed (12m <sup>2</sup> )	DRAWING NO.	A(10.10)03	
		REV NO. & DATE	Rev 1. Nov 2016	
		REV NOTE: Updated clear opening door width		

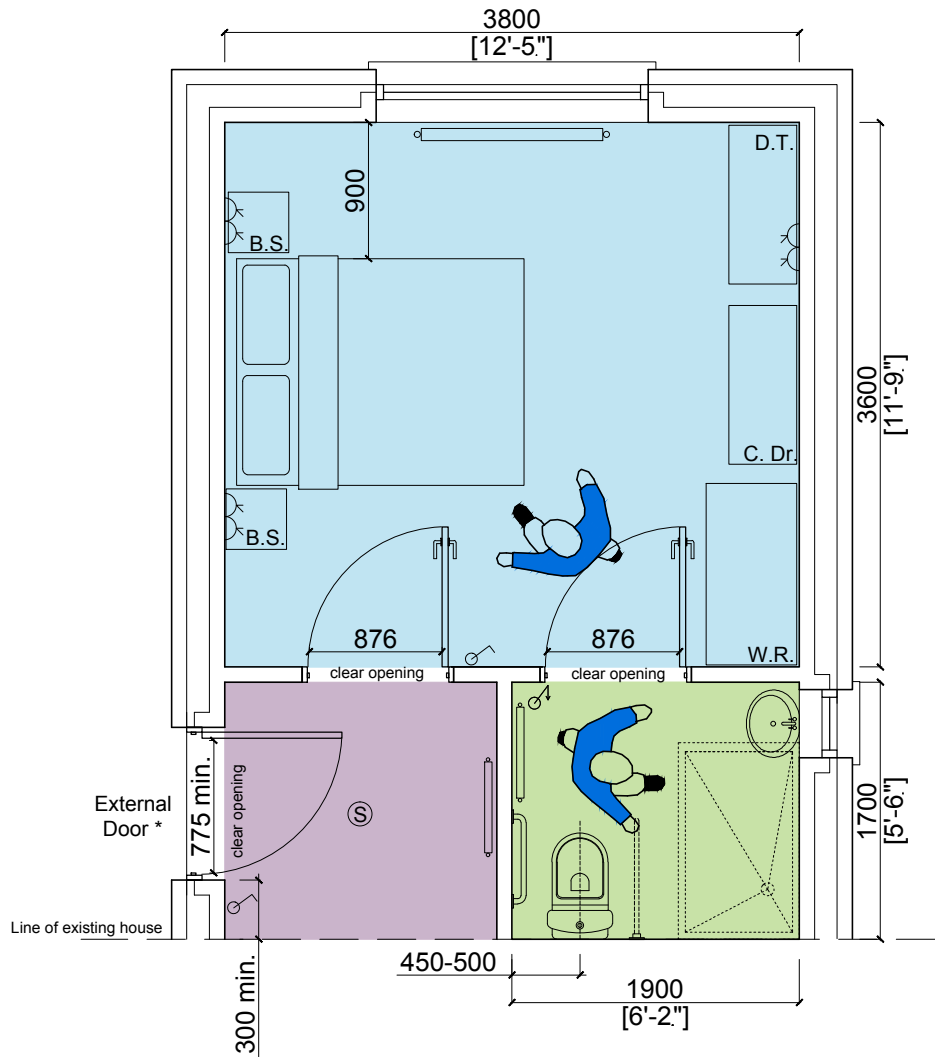

**KEY:**

Smoke Alarm - (S)

Bedroom - [Light Blue Box]

Bathroom - [Light Green Box]

Hallway - [Light Purple Box]

\* Level access to be provided at rear external door when requested by O.T., unless prohibited by site constraints or provided elsewhere.



TITLE	DRAWN BY	SCALE	DATE
Design Template 1E	P&S	1:50	Feb 2015
Ambulant User - Walking Aid Double Bedroom (13.68m <sup>2</sup> )	DRAWING NO.	A(10.10)04	
	REV NO. & DATE	Rev 1. Nov 2016	
REV NOTE: Updated clear opening door width			

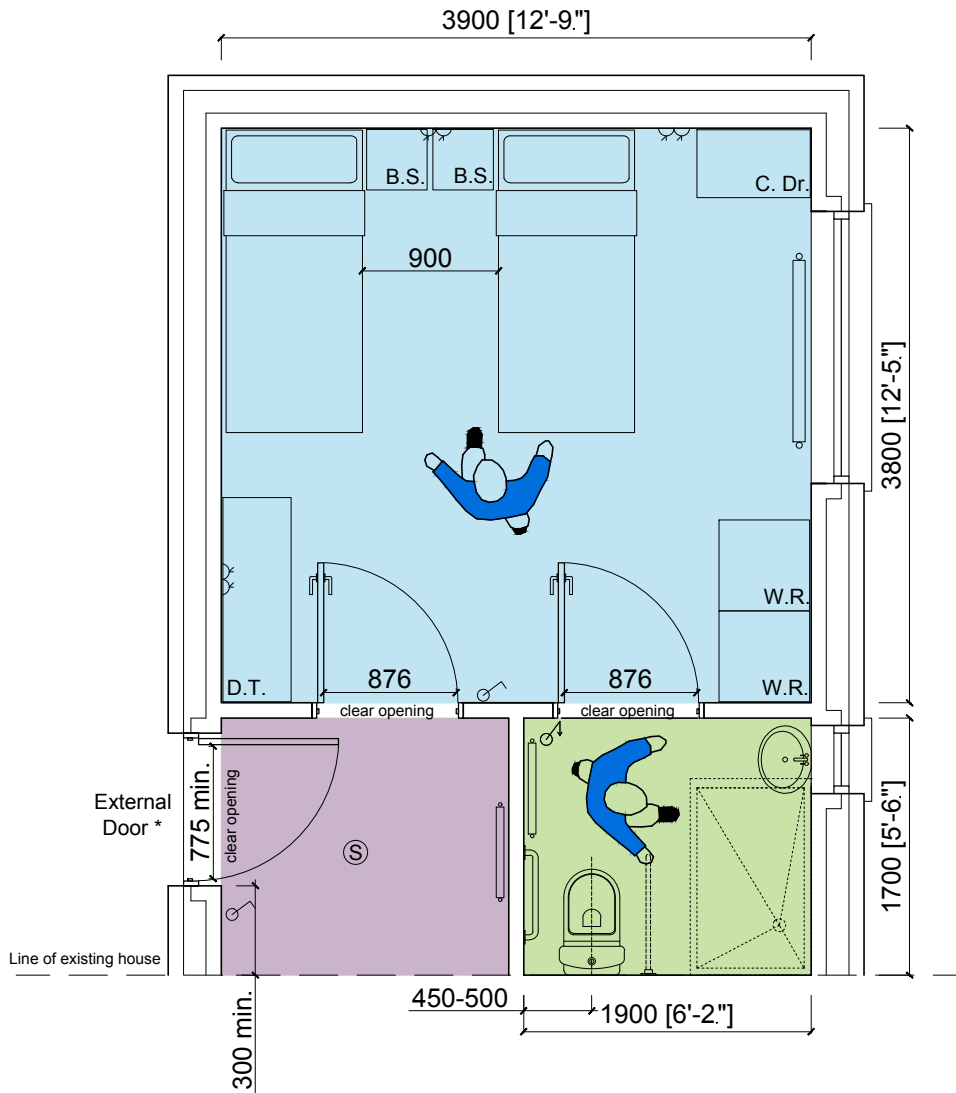

**KEY:**

- Smoke Alarm - (S)
- Bedroom - [Light Blue Box]
- Bathroom - [Light Green Box]
- Hallway - [Light Purple Box]

\* Level access to be provided at rear external door when requested by O.T., unless prohibited by site constraints or provided elsewhere.



<b>TITLE</b> Design Template 1F  Ambulant User - Walking Aid Twin Bedroom (14.82m <sup>2</sup> )	<b>DRAWN BY</b> P&S	<b>SCALE</b> 1:50	<b>DATE</b> Feb 2015
	<b>DRAWING NO.</b>	A(10.10)05	
	<b>REV NO. &amp; DATE</b>	Rev 1. Nov 2016	
	<b>REV NOTE:</b>	Updated clear opening door width	

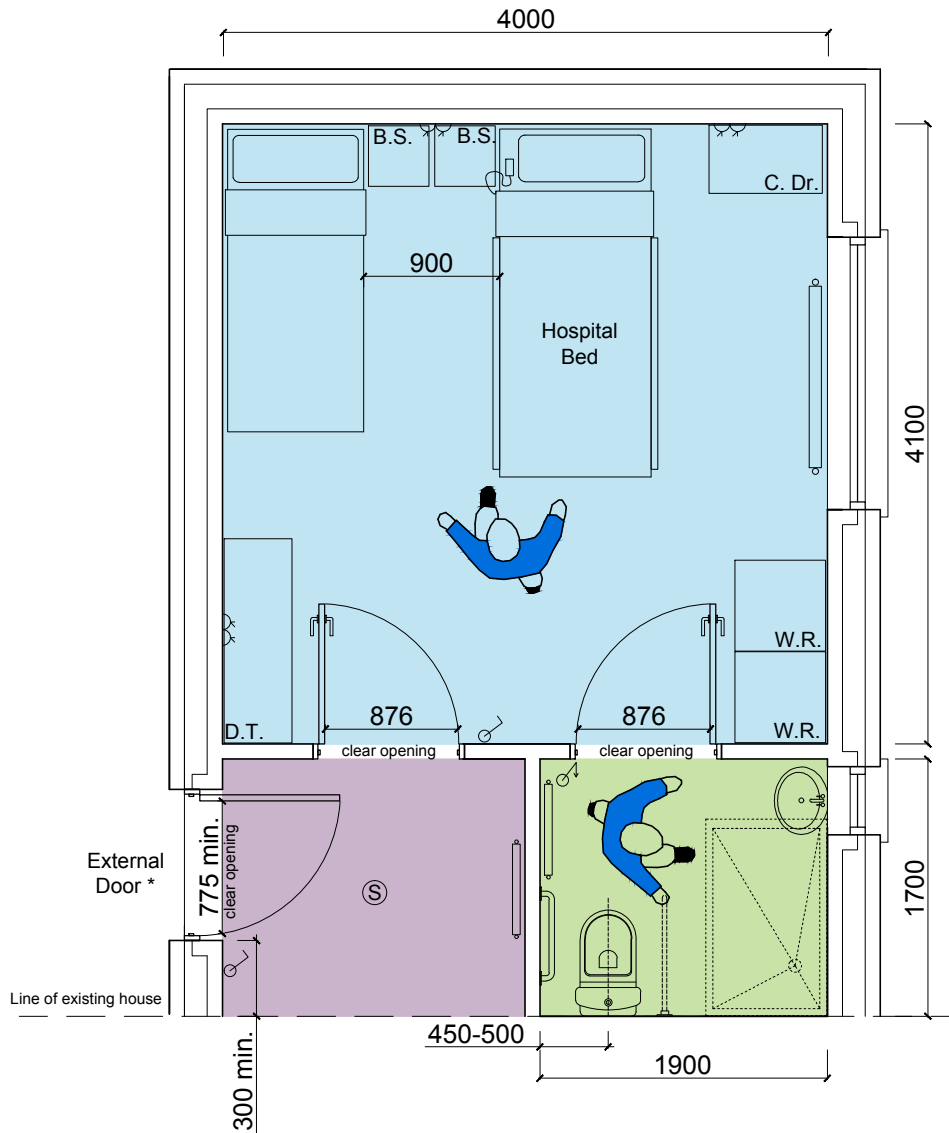

**KEY:**

Smoke Alarm - (S)

Bedroom - [Blue Box]

Bathroom - [Green Box]

Hallway - [Purple Box]

\* Level access to be provided at rear external door when requested by O.T., unless prohibited by site constraints or provided elsewhere.



TITLE	DRAWN BY	SCALE	DATE
Design Template 1G	P&S	1:50	Feb 2015
Ambulant User - Walking Aid Twin Bedroom with Hospital Bed (16.40m <sup>2</sup> )	DRAWING NO.	A(10.10)06	
	REV NO. & DATE	Rev 1. Nov 2016	
	REV NOTE:	Updated clear opening door width	

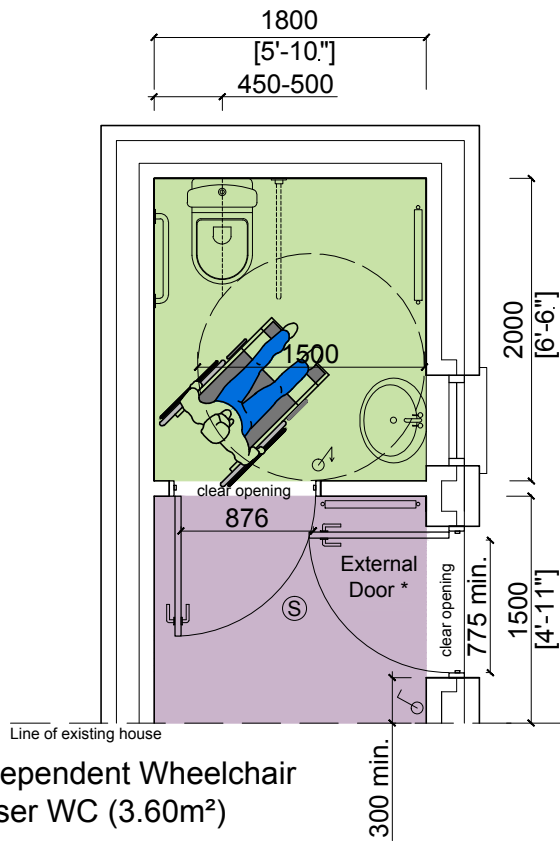

2A: Independent Wheelchair User WC (3.60m<sup>2</sup>)

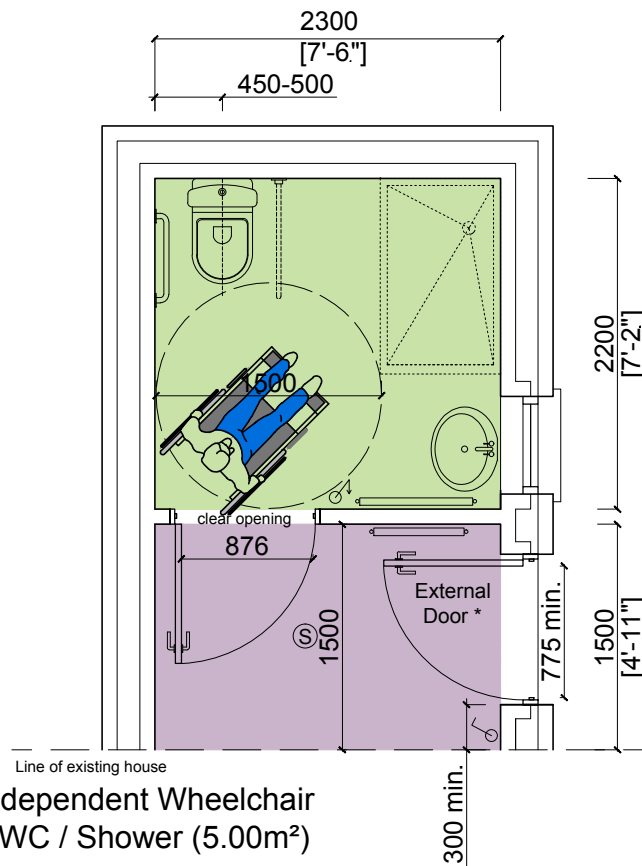

2B: Independent Wheelchair User WC / Shower (5.00m<sup>2</sup>)

KEY:

Smoke Alarm - (S)

Bedroom -

Bathroom -

Hallway -

\* Level access to be provided at rear external door, unless prohibited by site constraints or provided elsewhere.



<b>TITLE</b> Design Template 2A - Independent Wheelchair User WC (3.60m <sup>2</sup> ) Design Template 2B - Independent Wheelchair User WC / Shower (5.00m <sup>2</sup> )	<b>DRAWN BY</b> P&S	<b>SCALE</b> 1:50	<b>DATE</b> Feb 2015
	<b>DRAWING NO.</b>	A(10.11)01	
	<b>REV NO. &amp; DATE</b>	Rev 1 Nov. 2016	
	<b>REV NOTE:</b>	Updated clear opening door width	

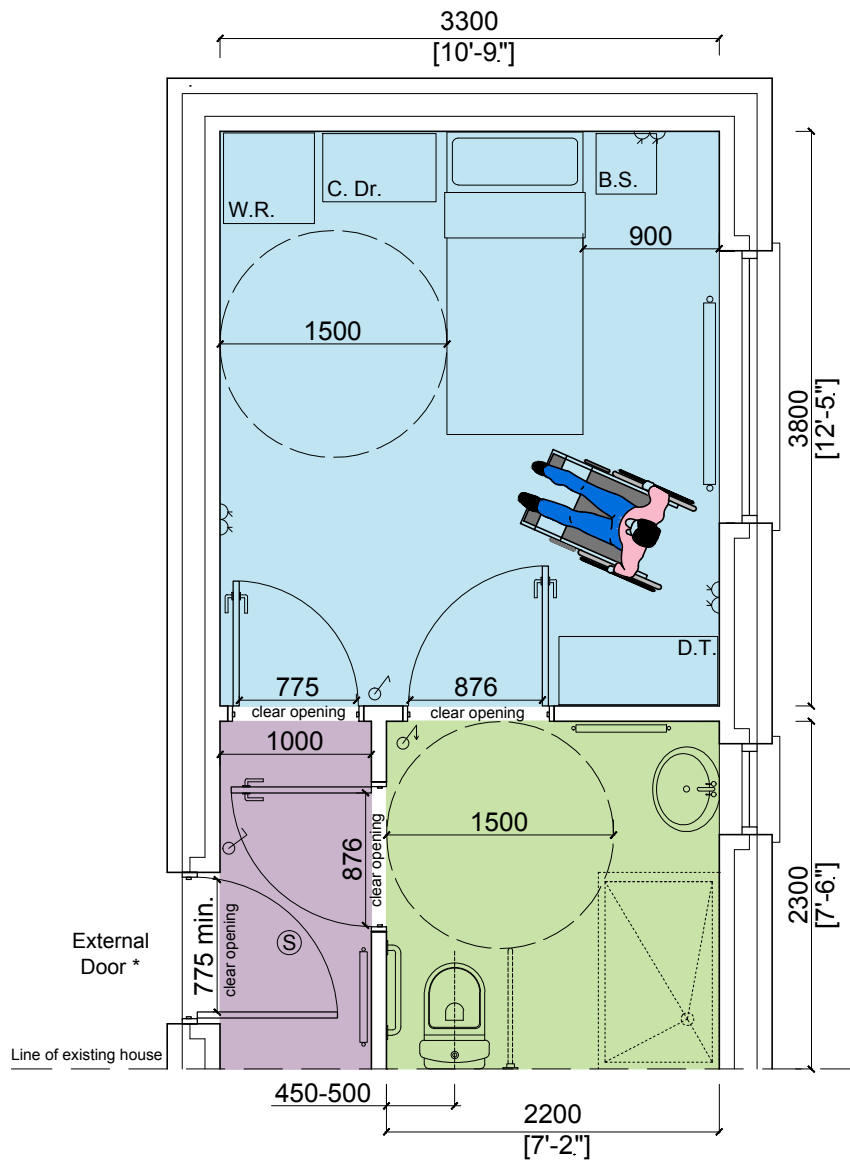

**KEY:**

Smoke Alarm - (S)

Bedroom - [Light Blue Box]

Bathroom - [Light Green Box]

Hallway - [Light Purple Box]

\* Level access to be provided at rear external door, unless prohibited by site constraints or provided elsewhere.



<b>TITLE</b> Design Template 2C  Independent Wheelchair User Single Standard Bedroom (12.54m <sup>2</sup> )	<b>DRAWN BY</b> P&S	<b>SCALE</b> 1:50	<b>DATE</b> Feb 2015
	<b>DRAWING NO.</b>	A(10.11)02	
	<b>REV NO. &amp; DATE</b>	Rev 1. Nov 2016	
	<b>REV NOTE:</b>	Updated clear opening door width	

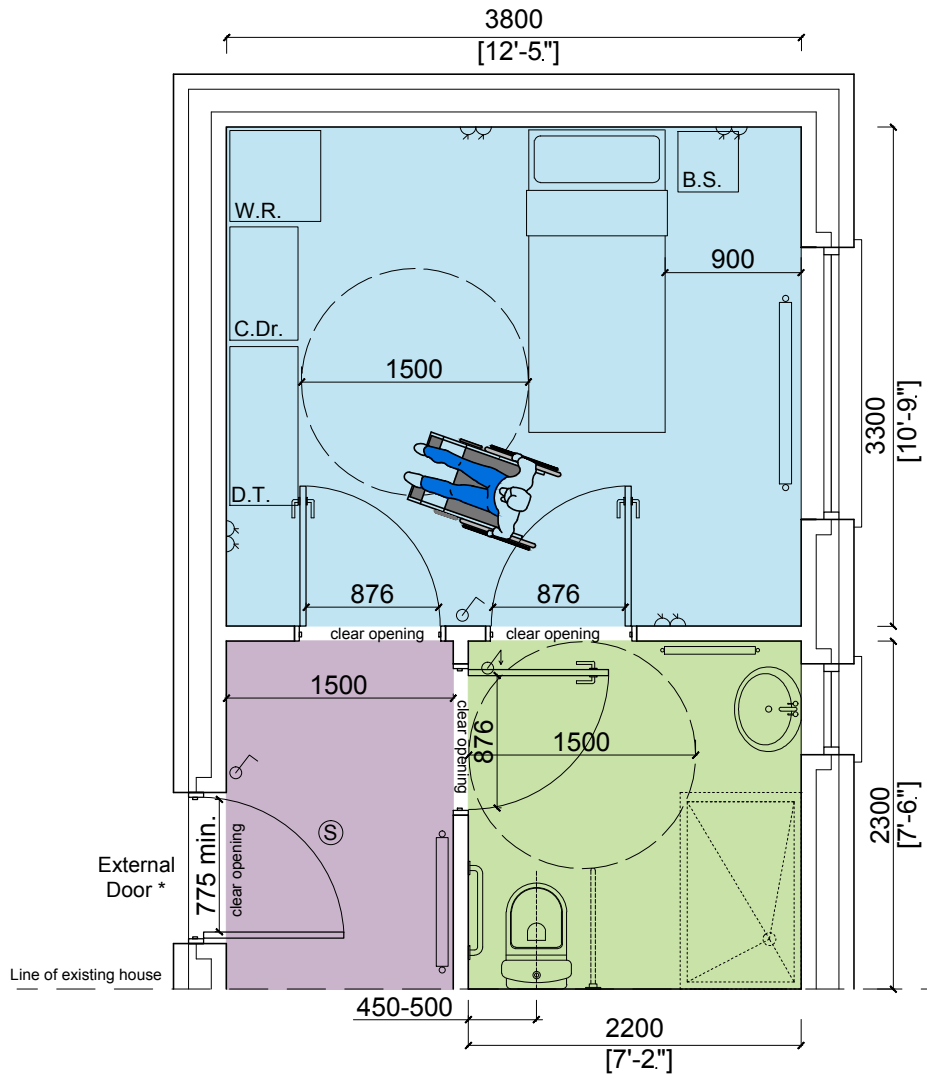

**KEY:**

Smoke Alarm - (S)

Bedroom - [Light Blue Box]

Bathroom - [Light Green Box]

Hallway - [Light Purple Box]

\* Level access to be provided at rear external door, unless prohibited by site constraints or provided elsewhere.



TITLE	DRAWN BY	SCALE	DATE
Design Template 2C(i)	P&S	1:50	Feb 2015
Independent Wheelchair User Single Standard Bedroom (12.54m <sup>2</sup> )	DRAWING NO.	A(10.11)03	
	REV NO. & DATE	Rev 1. Nov 2016	
	REV NOTE:	Updated clear opening door width	



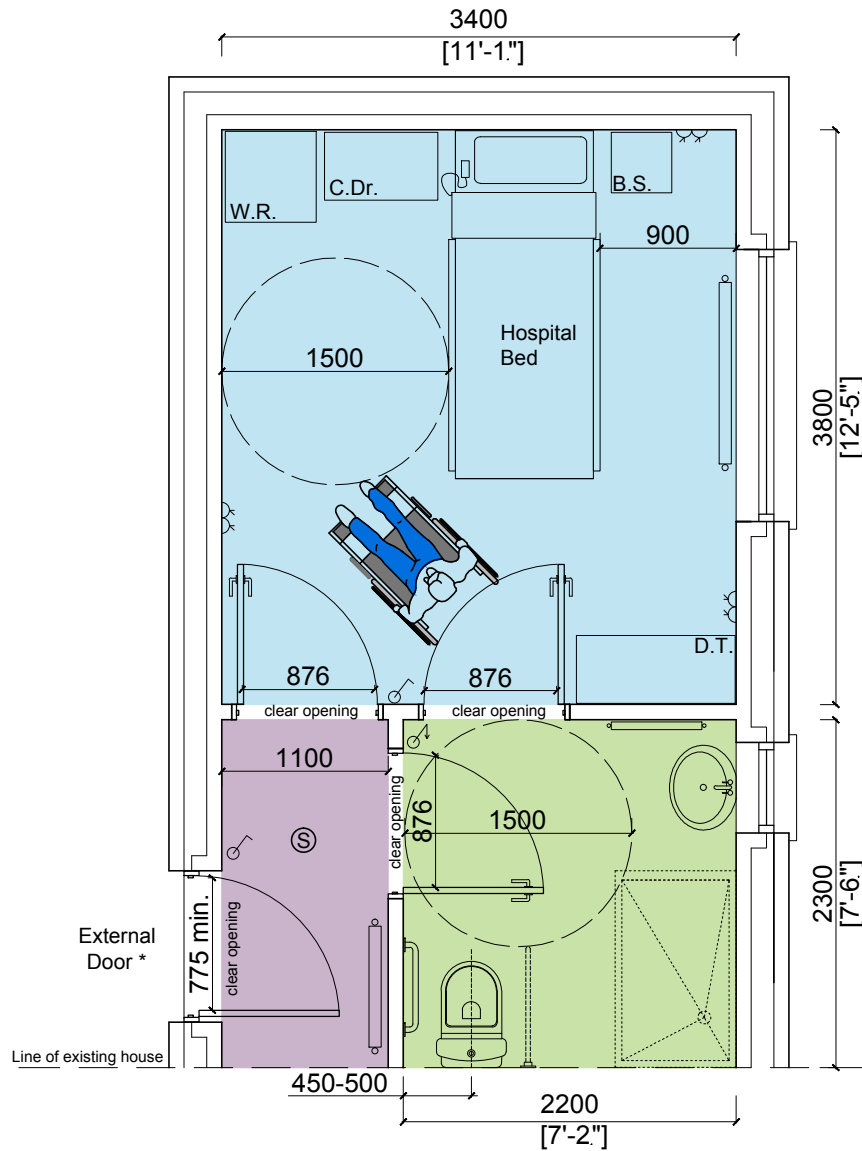

**KEY:**

Smoke Alarm - (S)

Bedroom - [Light Blue Box]

Bathroom - [Light Green Box]

Hallway - [Purple Box]

\* Level access to be provided at rear external door, unless prohibited by site constraints or provided elsewhere.



TITLE	DRAWN BY	SCALE	DATE
Design Template 2D	P&S	1:50	Feb 2015
Independent Wheelchair User Single Hospital Bed Bedroom (12.92m <sup>2</sup> )	DRAWING NO.	A(10.11)04	
	REV NO. & DATE	Rev 1. Nov 2016	
	REV NOTE:	Updated clear opening door width	

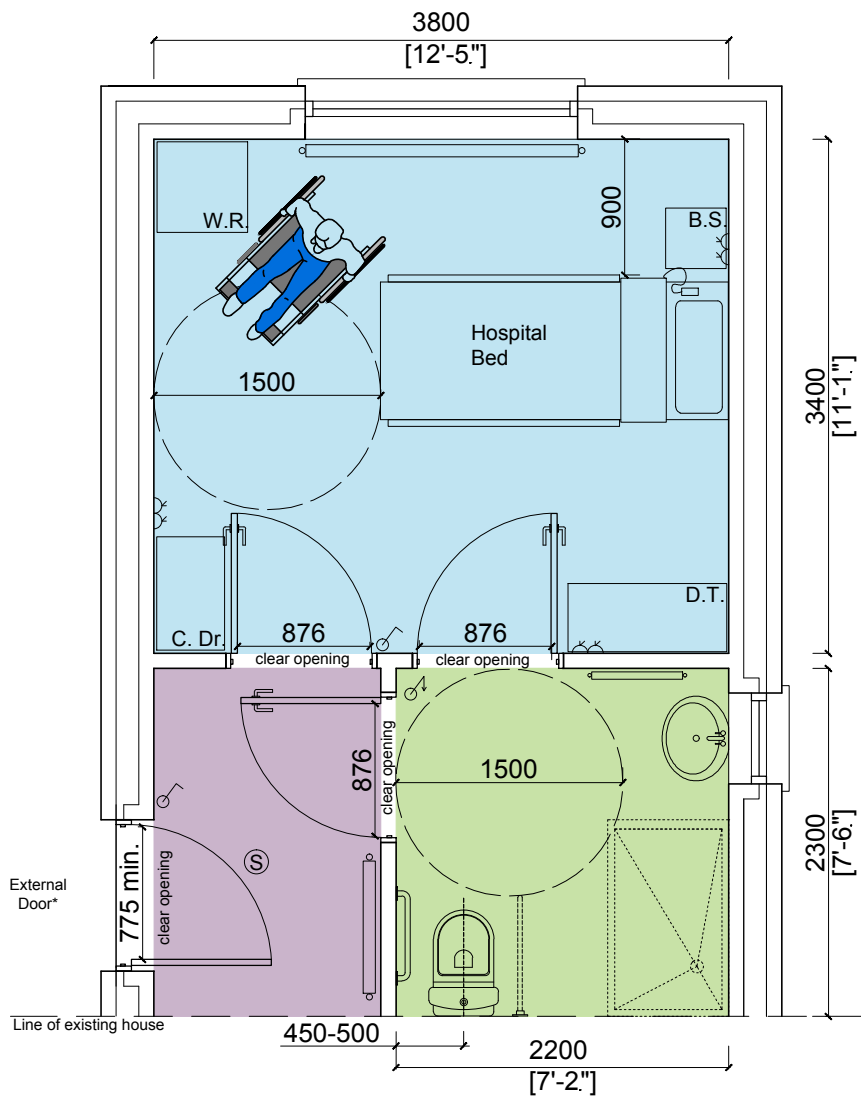

**KEY:**

Smoke Alarm - (S)

Bedroom - [Light Blue Box]

Bathroom - [Light Green Box]

Hallway - [Purple Box]

\* Level access to be provided at rear external door, unless prohibited by site constraints or provided elsewhere.



<b>TITLE</b> Design Template 2Di  Independent Wheelchair User Single (Hospital Bed) Bedroom (12.92m <sup>2</sup> )	<b>DRAWN BY</b> P&S	<b>SCALE</b> 1:50	<b>DATE</b> Feb 2015
	<b>DRAWING NO.</b>	A(10.11)05	
	<b>REV NO. &amp; DATE</b>	Rev 1. Nov 2016	
	<b>REV NOTE:</b>	Updated clear opening door width	

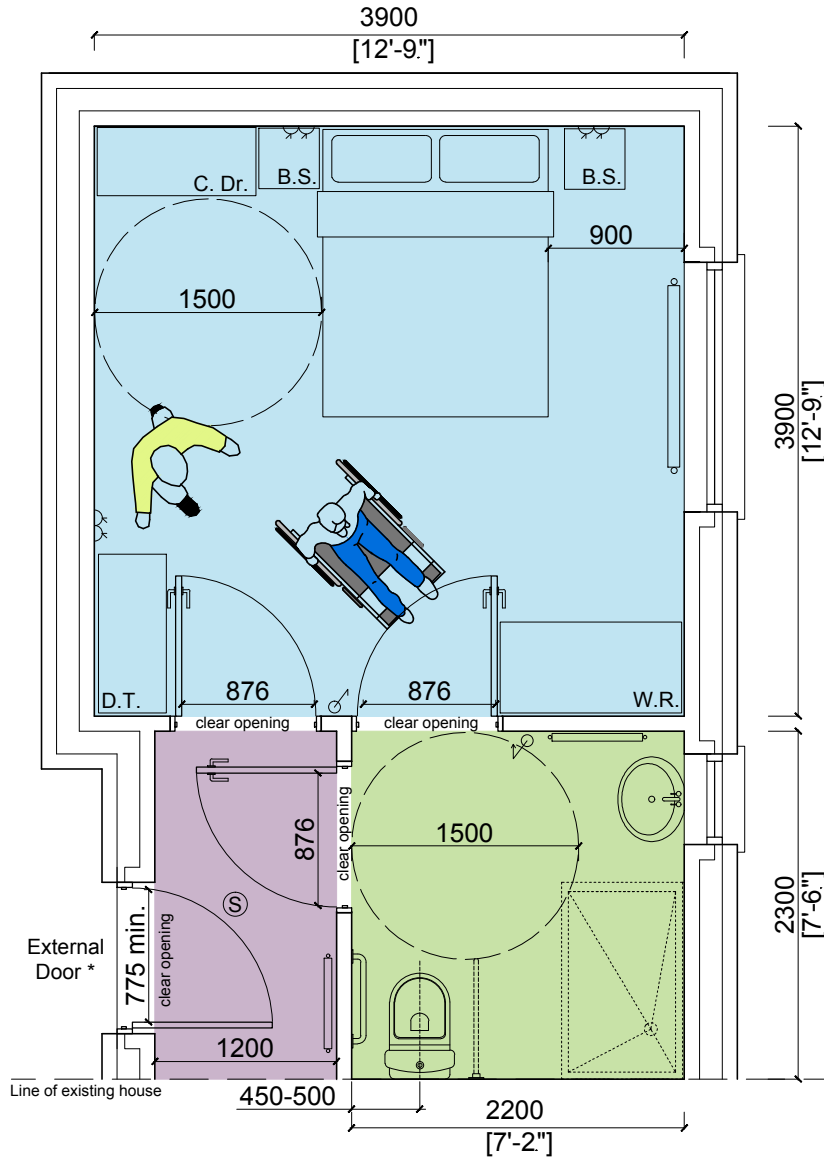

**KEY:**

Smoke Alarm - (S)

Bedroom -

Bathroom -

Hallway -

\* Level access to be provided at rear external door, unless prohibited by site constraints or provided elsewhere.



<p>TITLE</p> <p><b>Design Template 2E</b></p> <p>Independent Wheelchair User Double Standard Bedroom (15.21m<sup>2</sup>)</p>	<p>DRAWN BY</p> <p><b>P&amp;S</b></p>	<p>SCALE</p> <p><b>1:50</b></p>	<p>DATE</p> <p><b>Feb 2015</b></p>
	<p>DRAWING NO.</p> <p><b>A(10.11)06</b></p>		
	<p>REV NO. &amp; DATE</p> <p><b>Rev 1. Nov 2016</b></p>		
	<p>REV NOTE:</p> <p><b>Updated clear opening door width</b></p>		

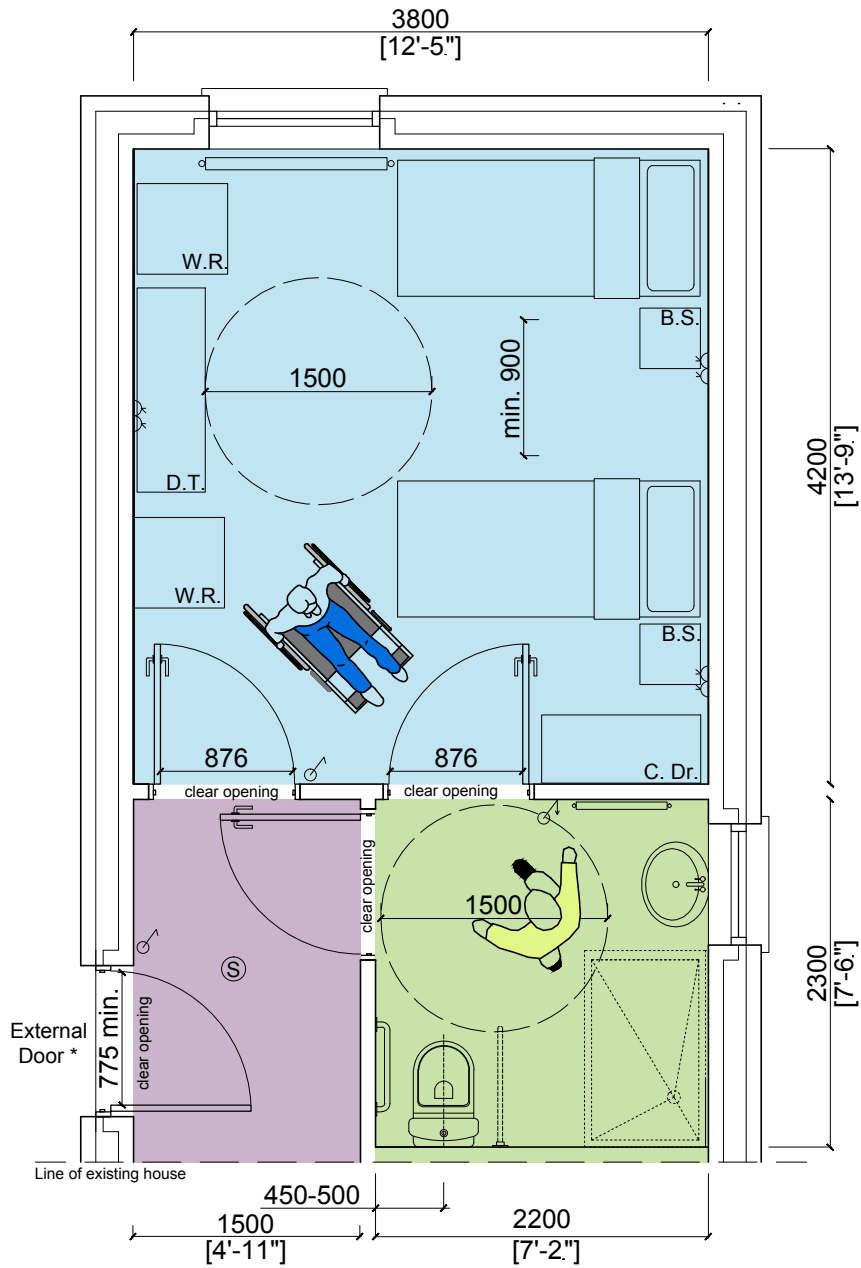

- KEY:**
- Smoke Alarm - (S)
  - Bedroom - [Light Blue Box]
  - Bathroom - [Light Green Box]
  - Hallway - [Purple Box]

\* Level access to be provided at rear external door, unless prohibited by site constraints or provided elsewhere.



<p>TITLE</p> <p><b>Design Template 2F</b></p> <p>Independent Wheelchair User Twin Standard Bedroom (15.96m<sup>2</sup>)</p>	<p>DRAWN BY</p> <p><b>P&amp;S</b></p>	<p>SCALE</p> <p><b>1:50</b></p>	<p>DATE</p> <p><b>Feb 2015</b></p>
	<p>DRAWING NO.</p>	<p><b>A(10.11)07</b></p>	
	<p>REV NO. &amp; DATE</p>	<p><b>Rev 1 Nov. 2016</b></p>	
	<p>REV NOTE:</p>		

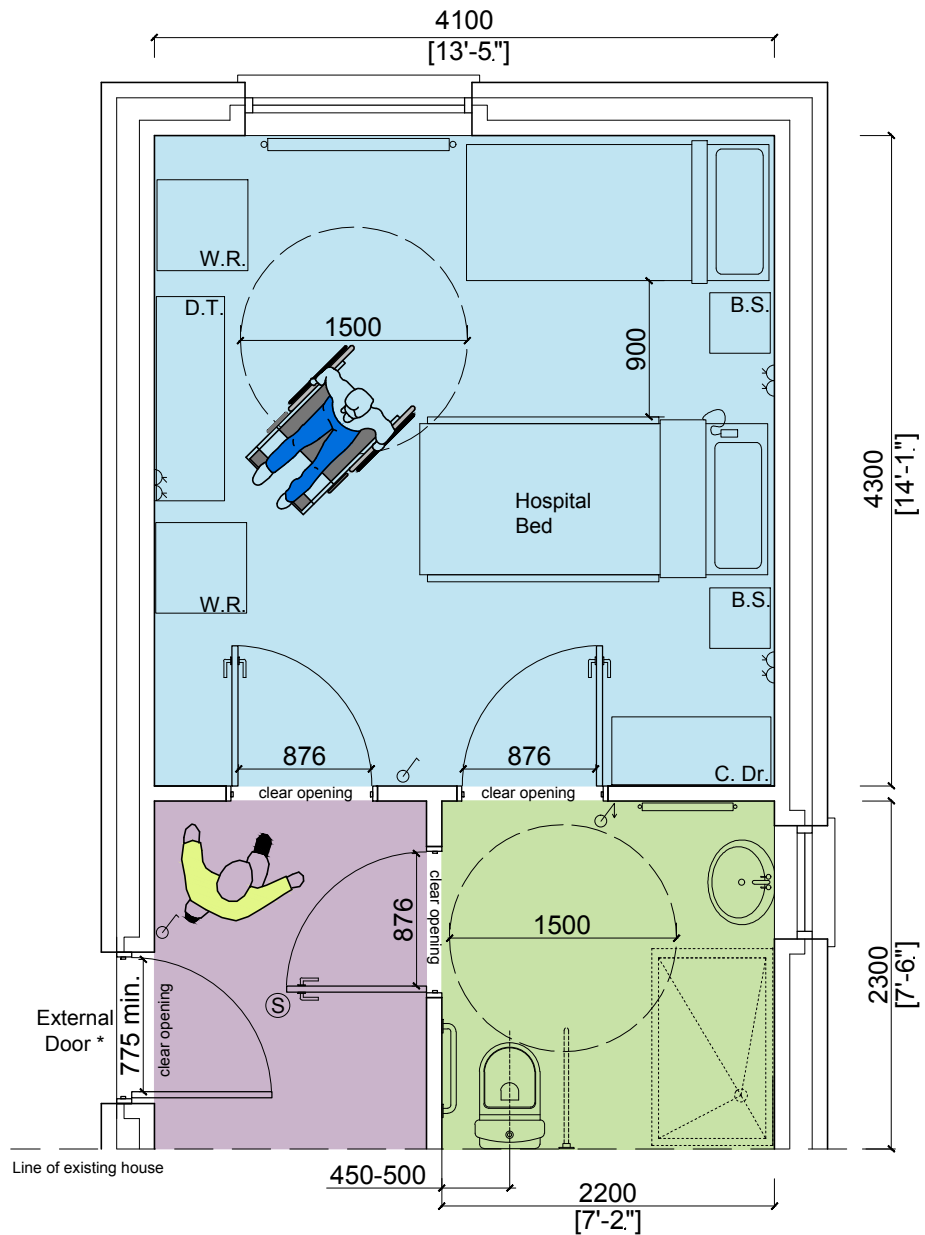

**KEY:**

Smoke Alarm - (S)

Bedroom - [Light Blue Box]

Bathroom - [Light Green Box]

Hallway - [Purple Box]

\* Level access to be provided at rear external door, unless prohibited by site constraints or provided elsewhere.

© NIHE 2015  
DRAWINGS NOT TO BE SCALED DUE TO PRINTING DISTORTION



**TITLE**  
Design Template 2G  
  
Independent Wheelchair User Twin (1 Standard & 1 Hospital Bed) Bedroom (17.63m<sup>2</sup>)

<b>DRAWN BY</b> P&S	<b>SCALE</b> 1:50	<b>DATE</b> Feb 2015
<b>DRAWING NO.</b>	A(10.11)08	
<b>REV NO. &amp; DATE</b>	Rev 1 Nov. 2016	
<b>REV NOTE:</b>	Updated clear opening door width	

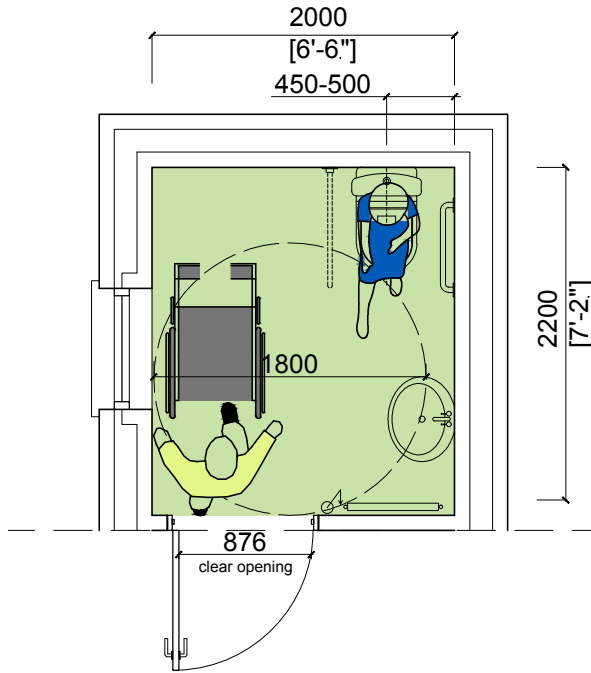

Design Template 3A

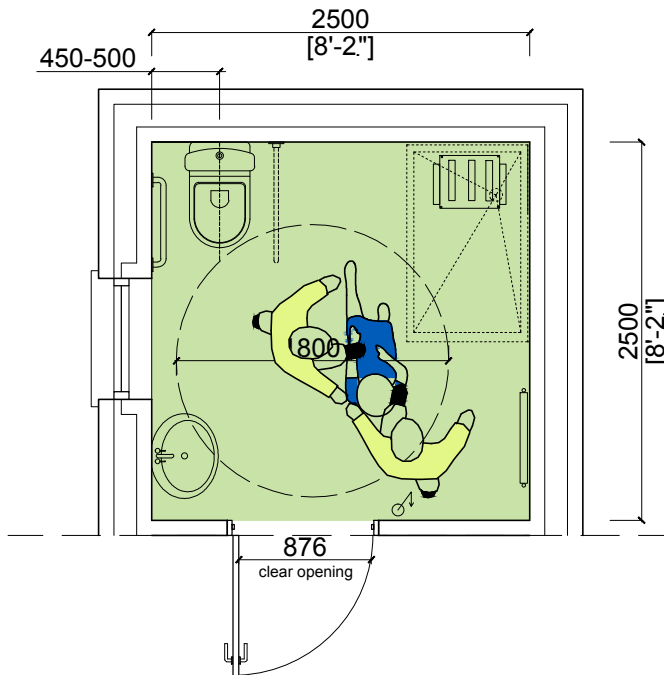

Design Template 3B

KEY:

Smoke Alarm - (S)

Bedroom - [Blue Box]

Bathroom - [Green Box]

© NIHE 2015  
DRAWINGS NOT TO BE SCALED DUE TO PRINTING DISTORTION



<b>TITLE</b> Design Templates 3A & 3B -  Assisted Wheelchair User WC - (4.40m <sup>2</sup> ) & WC/Shower Room for Assisted Wheelchair User - (6.25m <sup>2</sup> )	
--	--

<b>DRAWN BY</b> P&S	<b>SCALE</b> 1:50	<b>DATE</b> Feb 2015
<b>DRAWING NO.</b>	A(10.12)01	
<b>REV NO. &amp; DATE</b>	Rev 1. Nov 2016	
<b>REV NOTE:</b>	Updated clear opening door width	

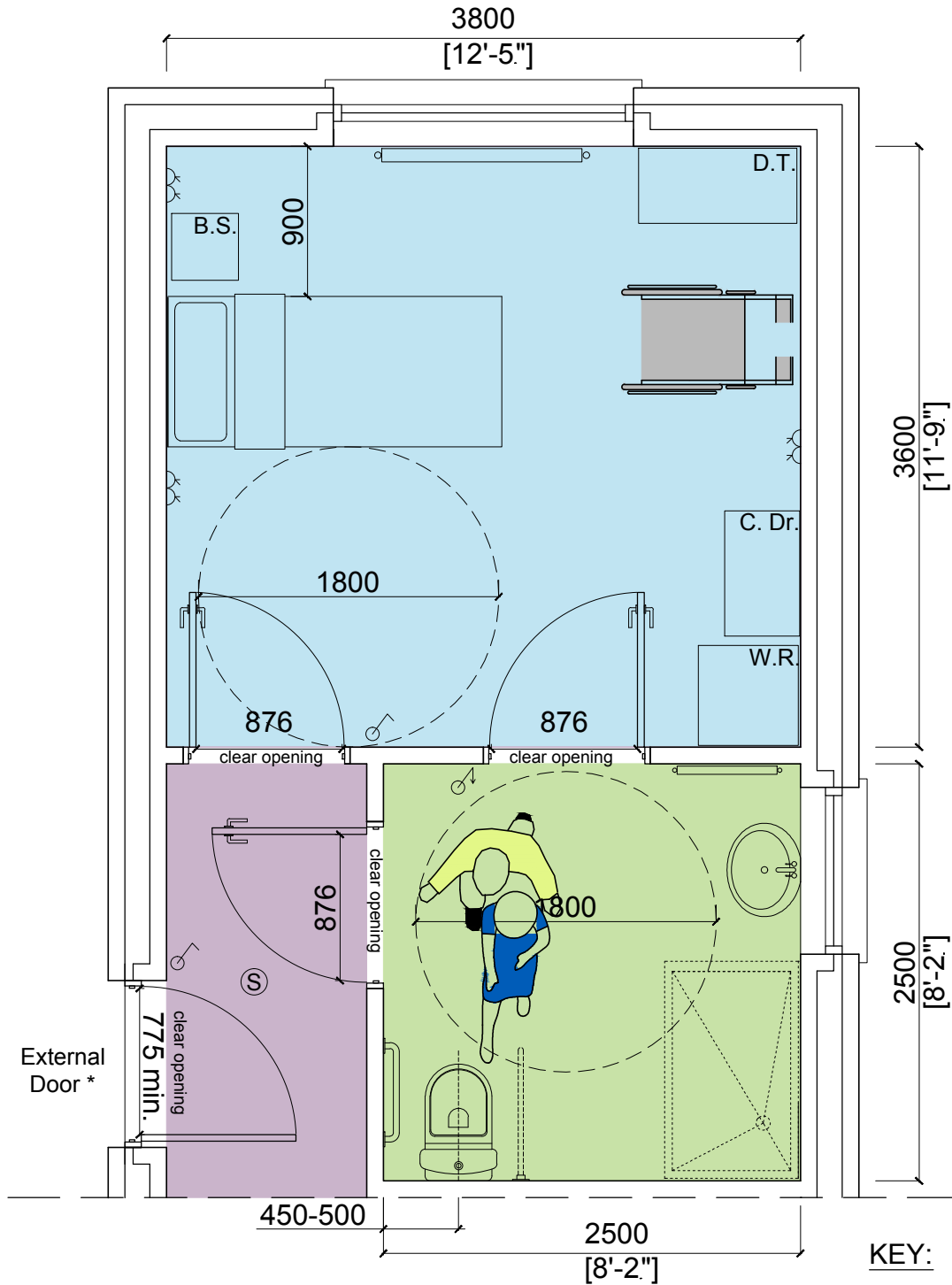

**KEY:**

- Smoke Alarm - (S)
- Bedroom -
- Bathroom -
- Hallway -

\* Level access to be provided at rear external door, unless prohibited by site constraints or provided elsewhere.

	TITLE	DRAWN BY	SCALE	DATE
	Design Template 3C	P&S	1:50	Feb 2015
	Assisted Wheelchair User Single Bedroom - (13.68m <sup>2</sup> )	DRAWING NO.	A(10.12)02	
		REV NO. & DATE	Rev 1. Nov 2016	
	REV NOTE:	Updated clear opening door width		

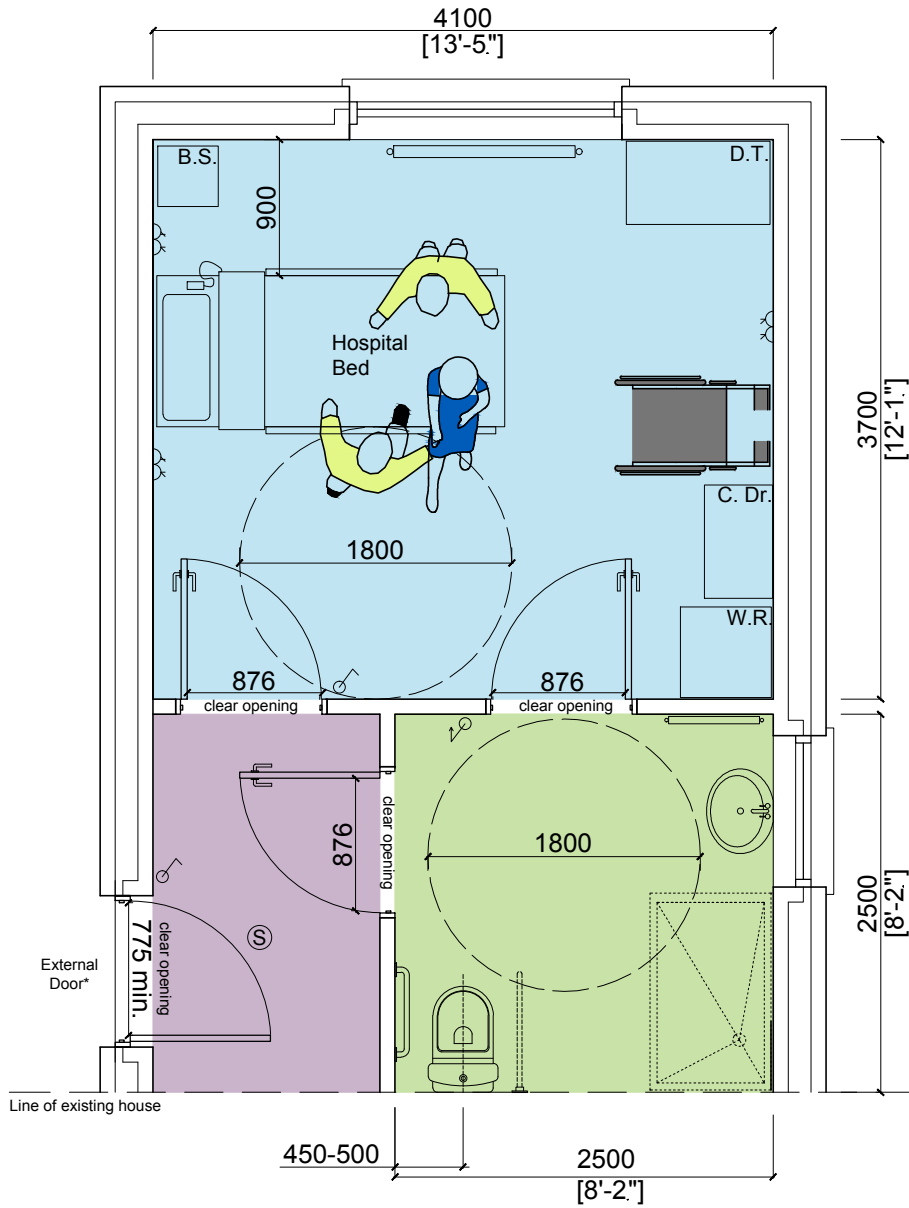

**KEY:**

Smoke Alarm - (S)

Bedroom - [Light Blue Box]

Bathroom - [Light Green Box]

Hallway - [Purple Box]

\* Level access to be provided at rear external door, unless prohibited by site constraints or provided elsewhere.



TITLE	Design Template 3D
	Assisted Wheelchair User Single Bedroom - (15.17m <sup>2</sup> )

DRAWN BY	P&S	SCALE	1:50	DATE	Feb 2015
DRAWING NO.	A(10.12)03				
REV NO. & DATE	Rev 1 Nov. 2016				
REV NOTE:	Updated clear opening door width				



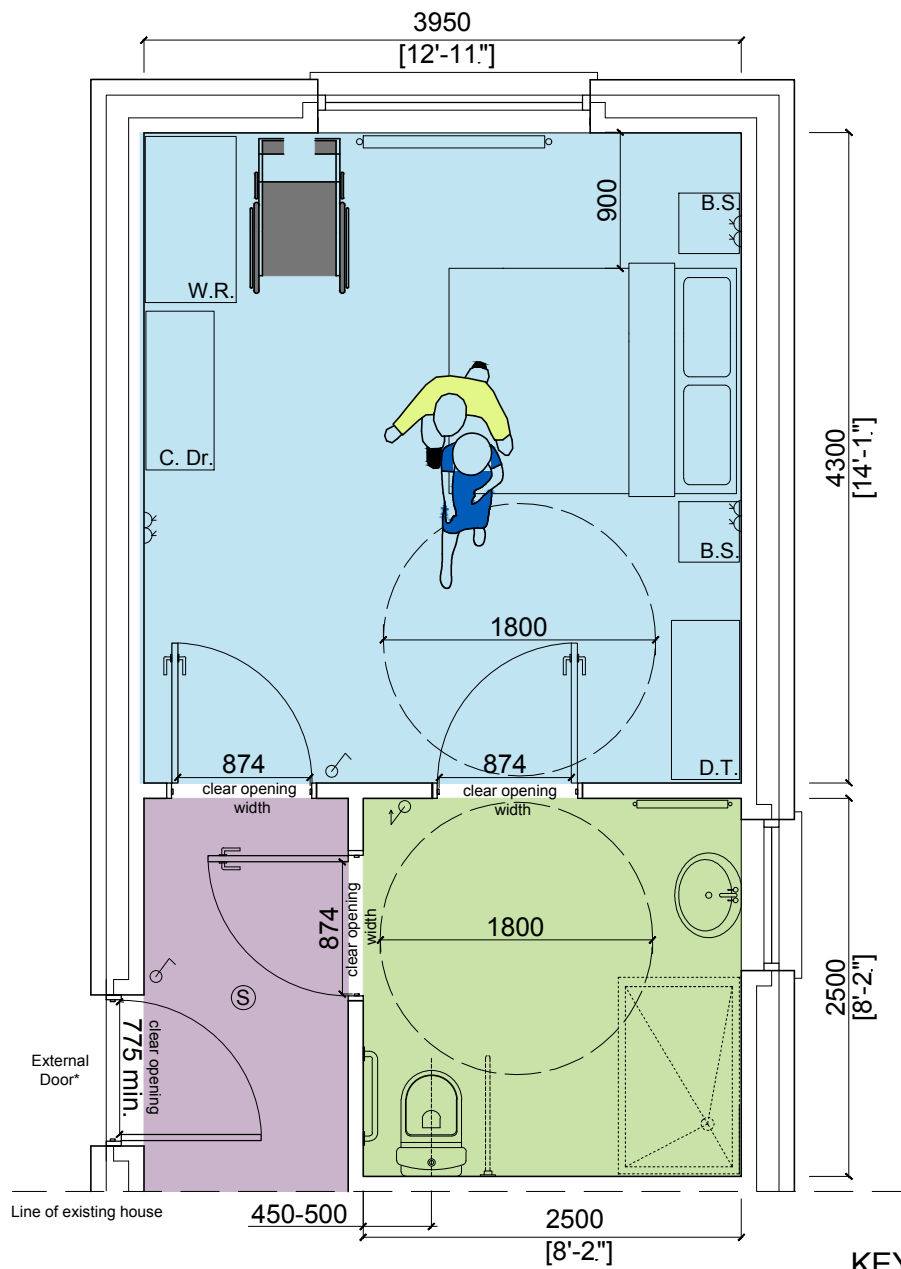

**KEY:**

Smoke Alarm - (S)

Bedroom - [Light Blue Box]

Bathroom - [Light Green Box]

Hallway - [Light Purple Box]

\* Level access to be provided at rear external door, unless prohibited by site constraints or provided elsewhere.



TITLE	DRAWN BY	SCALE	DATE
Design Template 3E	P&S	1:50	Feb 2015
Assisted Wheelchair User Double Bedroom - (16.59m <sup>2</sup> )	DRAWING NO.	A(10.12)04	
	REV NO. & DATE	Rev 1 Nov. 2016	
	REV NOTE:	Updated clear opening door width	

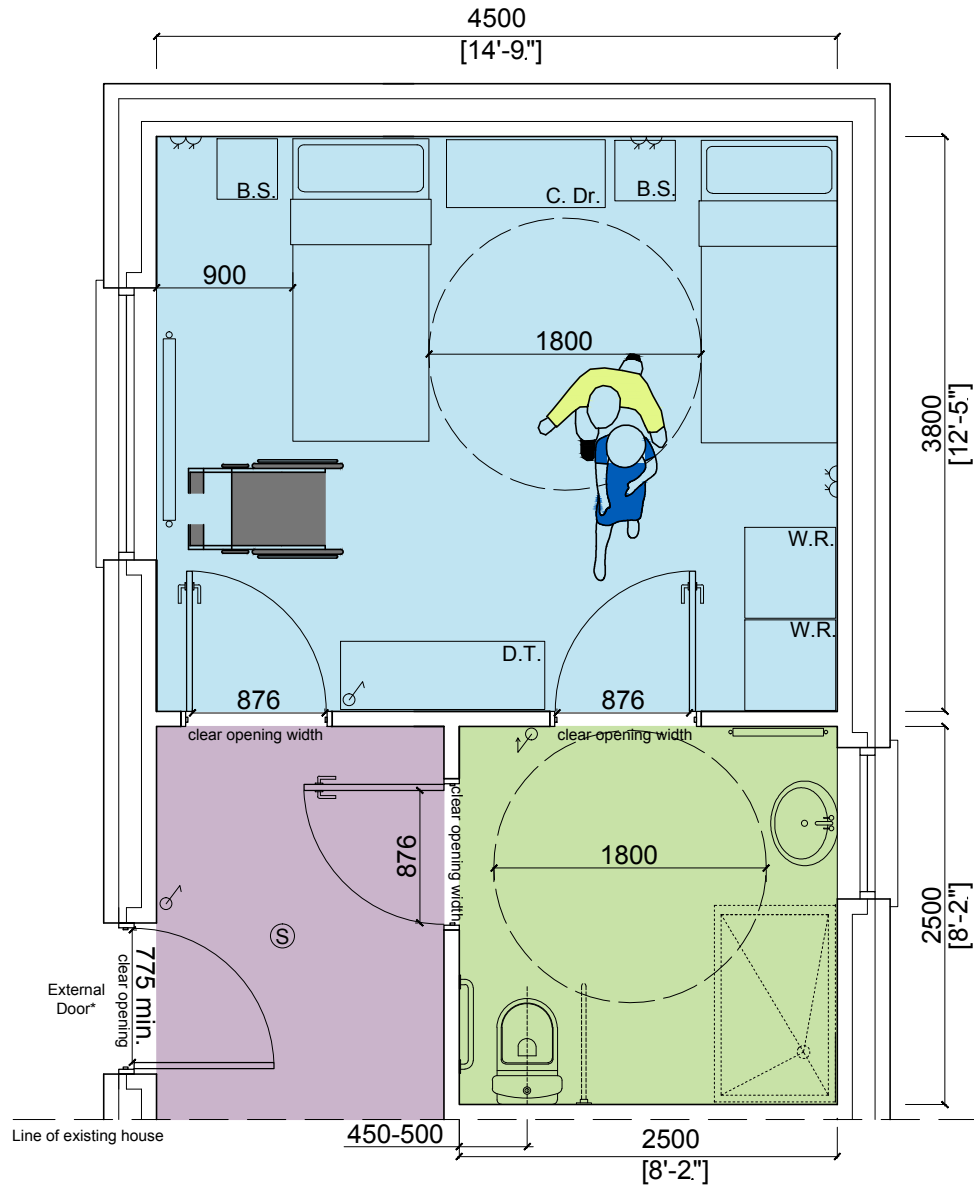

- KEY:**
- Smoke Alarm - (S)
  - Bedroom - [Light Blue Box]
  - Bathroom - [Light Green Box]
  - Hallway - [Light Purple Box]

\* Level access to be provided at rear external door, unless prohibited by site constraints or provided elsewhere.



<b>TITLE</b> Design Template 3F  Assisted Wheelchair User Twin Bedroom - (17.10m <sup>2</sup> )	<b>DRAWN BY</b> P&S	<b>SCALE</b> 1:50	<b>DATE</b> Feb 2015
	<b>DRAWING NO.</b>	A(10.12)05	
	<b>REV NO. &amp; DATE</b>	Rev 1 Nov. 2016	
	<b>REV NOTE:</b>	Updated clear opening door width	

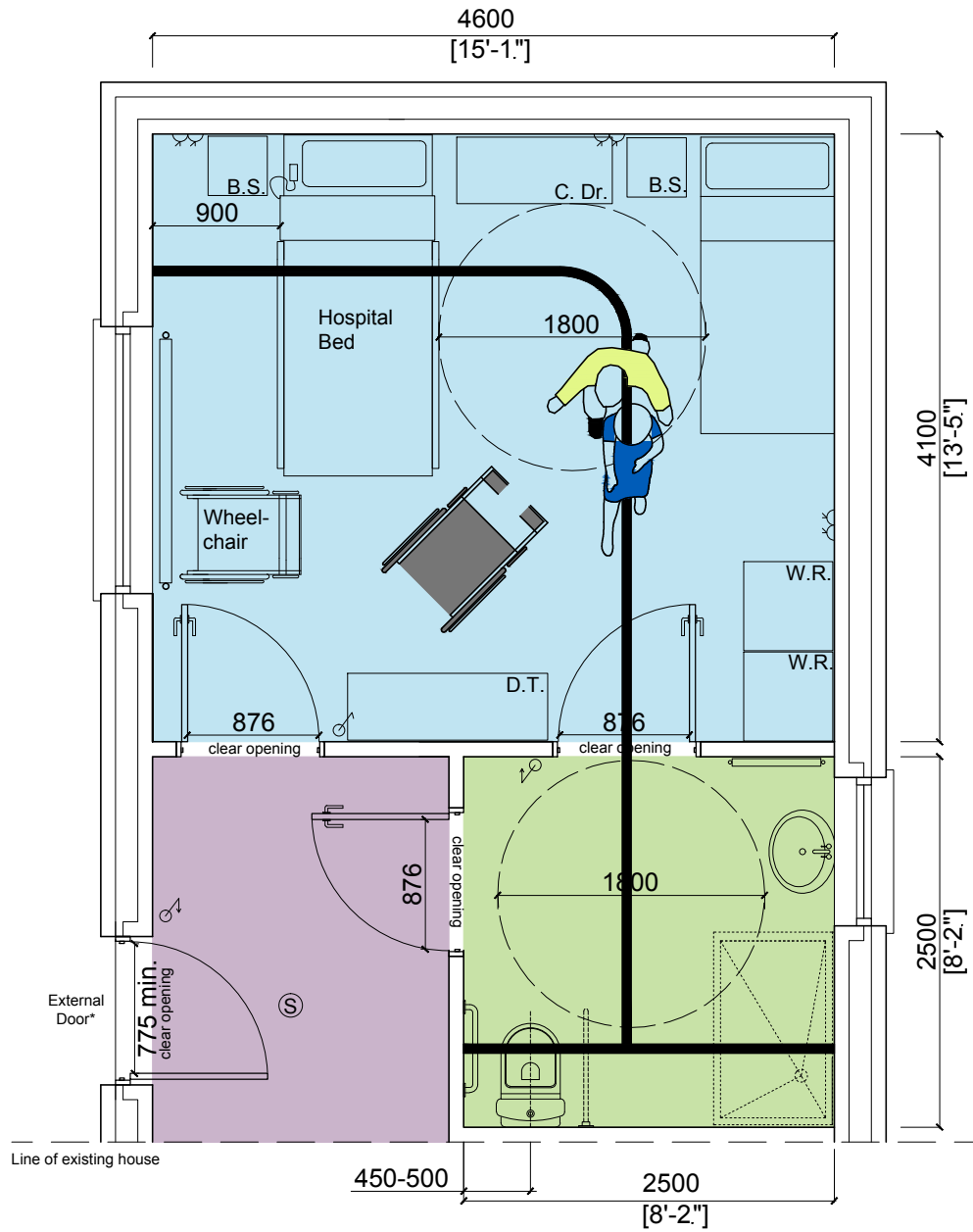

**NOTES-**

- The assisted wheelchair templates have been design to use a fixed tracking hoist.
- The position of the tracking is for illustration purposes only.
- If an alternative mobile hoist is preferred the optimum turning circle required is 2300mm.

\* Level access to be provided at rear external door, unless prohibited by site constraints or provided elsewhere.

**KEY:**

- Smoke Alarm - (S)
- Fixed tracking hoist -
- Bedroom -
- Bathroom -
- Hallway -



<b>TITLE</b> Design Template 3G  Assisted Wheelchair User Twin Bedroom (1 Standard & 1 Hospital Bed) - (18.86m <sup>2</sup> )	<b>DRAWN BY</b> P&S	<b>SCALE</b> 1:50	<b>DATE</b> Feb 2015
	<b>DRAWING NO.</b>	A(10.12)06	
	<b>REV NO. &amp; DATE</b>	Rev 1 Nov. 2016	
	<b>REV NOTE:</b>	Updated clear opening door width	

## FURNITURE / FITTINGS

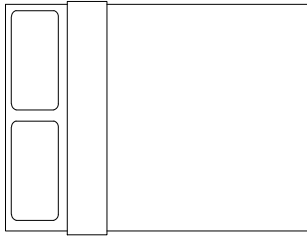

1500 x 2000mm  
Double Bed

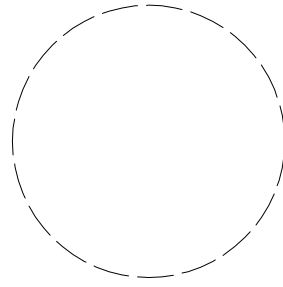

Turning Circle  
1500mm or 1800mm  
(as indicated on drawing)



900 x 2000mm  
Single Bed

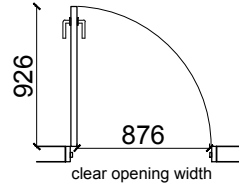

Typical Doorset  
(clear opening as shown  
on drawing, unless O.T.  
requests otherwise)

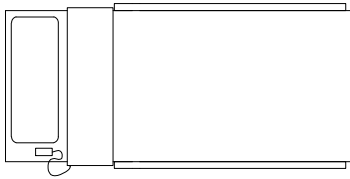

1000 x 2300mm  
Hospital Bed



Radiator



400 x 400mm  
Bedside cabinet

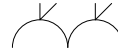

Double Socket



600 x 600mm  
Single Wardrobe



Standard Light Switch



600 x 1200mm  
Double Wardrobe



Pull Cord Light Switch

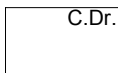

750 x 450mm Chest  
of Drawers/Desk  
(Single Bedroom)

## BATHROOM FITTINGS

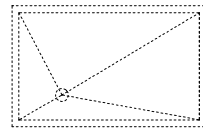

800 x 1300mm or 900 x  
1400mm floor former with  
Shower floor

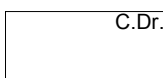

1050 x 450mm Chest  
of Drawers (Double  
Bedroom)



W.C.



450 x 1050mm Single  
Dressing Table/Desk  
(Single Bedroom)

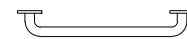

Grab Bar



450 x 1350mm Dressing  
Table (Double bedroom)

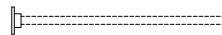

Drop-down Grab Rail

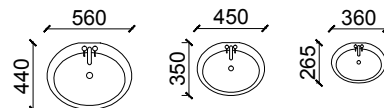

Wash Hand Basin



<p>TITLE</p> <p><b>ADAPTATIONS DESIGN TOOLKIT</b></p> <p><b>FURNITURE &amp; FITTINGS LEGEND</b></p>	<p>DRAWN BY <b>P&amp;S</b></p>	<p>SCALE <b>NTS</b></p>	<p>DATE <b>Feb 2015</b></p>
	<p>DRAWING NO.</p>	<p><b>S(10.10)01</b></p>	
	<p>REV NO. &amp; DATE</p>	<p><b>Rev 1 Nov 2016</b></p>	
	<p>REV NOTE: Updated clear opening door width &amp; WHB sizes</p>		