

# Introduction

This Technical Booklet has been prepared by the Department of the Environment for Northern Ireland and provides for certain methods and standards of building which, if followed, will satisfy the requirements of the Building Regulations (Northern Ireland) 1994 (“the Building Regulations”).

There is no obligation to follow the methods or comply with the standards set out in this Technical Booklet.

If you prefer you may adopt another way of meeting the requirements of the Building Regulations but you will have to demonstrate that you have satisfied those requirements by other means.

## Other regulations

This Technical Booklet relates only to the requirements of regulations E2, E4, E6, E8 and E10. The work will also have to comply with all other relevant Building Regulations.

## British Standards and European Technical Specifications

In this introduction and throughout this Technical Booklet any reference to a British Standard shall be construed as a reference to—

- (a) a British Standard or British Standard Code of Practice;
- (b) a harmonised standard or other relevant standard of a national standards body of any Member State of the European Economic Area;
- (c) an international standard recognised for use in any Member State of the European Economic Area;
- (d) any appropriate, traditional procedure of manufacture of a Member State of the European Economic Area which has a technical description sufficiently detailed to permit an assessment of the goods or materials for the use specified; or
- (e) a European Technical Approval issued in accordance with the Construction Products Directive,

provided that the proposed standard, code of practice, specification, technical description or European Technical Approval provides, in use, equivalent levels of safety, suitability and fitness for purpose as that provided by the British Standard.

## Products conforming with a European Council Directive

Any product designed and manufactured to comply with the requirements of a European Council Directive does not have to comply with any other standard or part of a standard, whether British, International or other, which relates to the same characteristic or specific purpose as the EC Directive.

## EC marked construction products

Any construction product (within the meaning of the Construction Products Directive) which bears an EC Mark shall be treated as if it satisfied the requirements of any appropriate British Board of Agrément Certificate, British Standard or British Standard Code of Practice relating to such a product, where the EC Mark relates to the same characteristic or specific purpose as the Certificate, Standard or Code of Practice.

## Testing of materials and construction

Where for the purposes of this Technical Booklet testing is carried out it shall be carried out by an appropriate organisation offering suitable and satisfactory evidence of technical and professional competence and independence. This condition shall be satisfied where the testing organisation is accredited in a Member State of the European Economic Area in accordance with the relevant parts of the EN 45000 series of standards for the tests carried out.

---

## **Materials and workmanship**

Any work to which a requirement of the Building Regulations applies must, in accordance with Part B of the Building Regulations, be carried out with suitable materials and in a workmanlike manner. You can comply with the requirements of Part B by following an appropriate British Standard or you may demonstrate that you have complied with those requirements by other suitable means, such as an acceptable British Board of Agrément Certificate, Quality Assurance Scheme, Independent Certification Scheme or Accredited Laboratory Test Certificate.

## **Diagrams**

The diagrams in this Technical Booklet supplement the text. They do not show all the details of construction and are not intended to illustrate compliance with any other requirement of the Building Regulations. They are not necessarily to scale and should not be used as working details.

## **References**

Any reference in this Technical Booklet to a publication shall, unless otherwise stated, be construed as a reference to the edition quoted, together with any amendments, supplements or addenda thereto current at 28 February 1994.

# Contents

	Page
<b>Foreword</b>	<b>4</b>
<b>Section 1 – Means of escape</b>	<b>8</b>
Dwellinghouses	8
General provisions	8
Roof space conversions	10
Automatic fire detection in dwellinghouses	10
Buildings other than dwellinghouses	13
Horizontal part of the escape route	13
Vertical part of the escape route	22
General provisions	28
<b>Section 2 – Internal fire spread – Linings</b>	<b>32</b>
Classification of performance of materials	32
Performance of wall and ceiling linings	33
<b>Section 3 – Internal fire spread – Structure</b>	<b>36</b>
Tests for fire resistance	36
Fire resistance of elements of structure and certain other components of the building	36
Compartmentation	43
Protected shafts between compartments	46
Fire doors	48
Provision of cavity barriers	50
Pipes penetrating compartment walls, compartment floors, protected shafts and cavity barriers	56
Car parks for light vehicles	60
<b>Section 4 – External fire spread</b>	<b>61</b>
Construction of external walls	61
Space separation – External walls	63
Canopies	73
Roofs	74
<b>Section 5 – Facilities and access for the Fire Brigade</b>	<b>81</b>
Firefighting shafts	81
Venting of heat and smoke from basements	83
Vehicle access	84
<b>Section 6 – Common provisions</b>	<b>86</b>
Purpose groups	86
Rules for measurement	88
Non-combustible materials	90
Materials of limited combustibility	90
Definitions	91
<b>Appendix – Publications referred to</b>	<b>95</b>

# Foreword

**0.1** The provisions set out in this Technical Booklet under Sections 1 to 5 deal with different aspects of fire safety. Whilst the provisions appropriate to each of these aspects are set out separately, many of the provisions are closely interlinked. For example, there is a close link between the provisions for means of escape (Section 1) and those for the control of fire growth (Section 2), fire containment (Section 3) and facilities for the Fire Brigade (Section 5). Similarly, there are links between Section 3 and the provisions for controlling external fire spread (Section 4), and between Section 3 and Section 5. Interaction between these different provisions should be recognised when considering alternative solutions as the adoption of a higher standard of provision in respect of one aspect may be of benefit in respect to the provisions relating to one or more other aspects. Thus the provisions in the Technical Booklet as a whole should be considered as a package aimed at achieving an acceptable standard of fire safety.

## Provisions common to more than one Section

**0.2** Within this Technical Booklet there are a number of matters which are relevant to more than one Section. Generally these have been located in the most appropriate Section and cross referenced where necessary. However, the classification of purpose groups, the methods for measurement and definitions are needed for all Sections and these have been drawn together for common reference in Section 6.

## Section 1 – Means of escape

**0.3** The provisions in this Section are concerned with ensuring that occupants are given warning of, and have a means of escape from, a fire. They only refer to structural fire precautions where these are necessary to safeguard an escape route. They have been prepared on the basis that the occupants of any part of a building should be able to escape from the building, in the event of a fire, without (in most cases) external assistance.

In dwellings and certain other buildings an automatic fire detection and alarm system can significantly increase the level of safety by automatically giving an early warning of fire. In other buildings an appropriate fire alarm system will provide adequate warning to occupants.

The design of the means of escape is based on the assumption that a fire will start in only one location and initially be a hazard in that area only. Subsequently it may spread to other parts, usually through circulation routes. Furnishings and equipment are not covered by the Building Regulations but are usually the items first ignited in a fire. A fire is less likely to start within the structure of the building or in a circulation area.

The primary danger in the early stages of a fire is not flame but smoke and other products of combustion which can directly affect the occupants of the building and obscure the escape routes. Measures designed to provide safe means of escape must therefore include provisions to limit the spread of smoke and other products of combustion.

The basic principles for the design of means of escape are –

- (a)** there shall be alternative means of escape from most locations so that people can turn their back on a fire and travel away from it to a place of safety; and
- (b)** where direct escape to a place of safety is not possible, the aim is to reach a place of relative safety, such as a protected stairway, within a reasonable travel distance. In such cases the escape route will consist of two parts – the first part in unprotected rooms and circulation areas, and the second part in protected stairways and in some circumstances protected corridors.

A protected stairway is considered to be a place of relative safety within which people can proceed at their own pace to a place of safety. Smoke and flames must be excluded from protected stairways by fire and smoke-resisting construction or by an appropriate smoke control system or both.

---

The following are not acceptable for means of escape –

- (i) a lift (except a suitably designed and installed lift for use by disabled people);
- (ii) a passenger conveyor or escalator;
- (iii) a portable or throw-out ladder; and
- (iv) manipulative apparatus and appliances.

## **Section 2 – Internal fire spread – Linings**

**0.4** The materials used for the linings of walls and ceilings in a building can significantly affect the spread of fire and its rate of growth. The provisions in Section 2 restrict the spread of fire over internal linings by ensuring they have low rates of surface spread of flame. In some locations the internal linings must also have a low rate of heat production so as to limit the contribution that the fabric of the building makes to fire growth.

There are no provisions in relation to the upper surfaces of floors and stairs because such surfaces are not involved significantly in a fire until it is well developed. They do not therefore play an important part in fire spread during the early stages of a fire, which are the most relevant to the life safety of occupants.

Although furniture and fittings can have a major effect on fire spread it is not possible to control them through Building Regulations, and no provisions relating to them are included in this Technical Booklet. The fire characteristics of furniture and fittings may be controlled in some buildings under other legislation which applies to those buildings when in use.

## **Section 3 – Internal fire spread – Structure**

**0.5** The spread of fire within a building can be restricted by the provision of structural measures such as fire-resisting elements of construction, compartmentation, cavity barriers and fire-stopping.

Fire-resisting elements of construction – the objective of providing the elements of structure and certain other components of the building with a minimum standard of fire resistance is to minimise the risk to the occupants whilst evacuating, to the firefighting personnel whilst engaged in search and rescue operations and to people in the vicinity of the building who may be hurt by falling debris or as a result of the impact of the collapsing building on another building.

Compartmentation – the spread of fire within a building can be restricted by subdividing it into compartments separated from one another by walls and/or floors of fire-resisting construction. The objectives are to prevent rapid fire spread, which could trap occupants of the building, and to reduce the chance of a fire becoming large, on the basis that a large fire is more dangerous, not only to occupants and fire-fighting personnel, but to people in the vicinity of the building.

Cavity barriers – concealed and extensive spaces within construction provide a ready route for the hidden spread of smoke and flame. The objectives of cavity barriers are to limit the extent of such spaces and to subdivide them where they would otherwise form a pathway around fire-resisting construction.

Protection of penetrations – in order that the fire integrity of elements of structure intended to provide fire separation is maintained, penetrations of such construction, by pipes, ducts, cables, etc. must be suitably protected.

Fire-stopping – the objective of fire-stopping is to adequately seal or protect every joint, imperfection of fit, opening and penetration in an element of structure intended to provide fire separation, so that its effectiveness is not impaired.

This Section also contains provisions relating to car parks for light vehicles. In buildings or separated parts of buildings used as parking for cars and other light vehicles the fire load is well defined and not particularly high. Fire spread is not likely to occur between one vehicle and another and, where the car park is well ventilated (so that heat and smoke can dissipate readily) there is a low probability of fire spread from one storey to another.

## **Section 4 – External fire spread**

**0.6** The extent to which fire will spread over and between buildings depends on the size and intensity of the fire, the construction of the external walls and roof, and the distance between the buildings.

Construction of walls – the fire resistance of an external wall and the combustibility of its external face are controlled to reduce its susceptibility to ignition from an external source and the danger from fire spreading up the external face of the building.

---

Construction of roofs – the combustibility of the external surface of a roof is controlled to reduce its susceptibility to ignition from an external source.

Distance between buildings – adequate separation between buildings is achieved by relating the amount of unprotected area (e.g. windows, areas of combustible wall, etc.) in the wall of a building or compartment to the distance that wall is from its relevant boundary. It may be advantageous to reduce compartment sizes or to provide compartmentation where none would otherwise be necessary, as this will reduce the size of the fire and may permit a reduced boundary distance or alternatively, an increase in unprotected area.

## **Section 5 – Facilities and access for the Fire Brigade**

**0.7** The provisions relating to facilities and access are for the purposes of assisting the Fire Brigade to ensure the safety of people in and around a building.

Generally in small buildings the combination of the access offered by the normal means of access and egress, and the ability of the fire Brigade to work from ladders and appliances are sufficient without special access or internal facilities. However, in large buildings and buildings with basements the Fire Brigade will invariably work inside the building and firefighting shafts, fire mains, venting of basements and access will be necessary.

Firefighting shafts – the provisions are to ensure that the Fire Brigade will have a secure operating base on every storey of large buildings.

Fire mains – the purpose of a fire main within a firefighting shaft is to enable firefighters to connect hoses and receive a supply of water for firefighting and rescue activities.

Access – the provisions relating to vehicle access are to enable the Fire Brigade's pumping appliances to supply water to the fire mains and for high reach appliances to be deployed.

Venting of basements – the enclosed nature of a basement prevents the dispersal of heat and smoke, which tend to rise up the access that the Fire Brigade may be using to approach the fire. The provisions for smoke removal facilities are to enable firefighters to more effectively search for and rescue any people who may be trapped, and to locate and attack the fire.

## **Fire safety engineering**

**0.8** A fire safety engineering approach which takes into account the total fire safety package within a building may provide an adequate level of fire safety. Indeed, it may be the only viable approach to the achievement of a satisfactory standard in some large and complex buildings but it is beyond the scope of this Technical Booklet.

## **Fire safety for disabled people**

**0.9** Deemed to satisfy provisions for means of escape for disabled people are contained in BS 5588: Part 8: 1988. However, incorporating special structural measures to aid means of escape for disabled people may not be needed where it can be shown that adequate management arrangements to provide assisted escape will be available.

## **Other legislation**

**0.10** The provisions of this Technical Booklet relate to the requirements of the Building Regulations and do not include measures which may be necessary to meet the requirements of other legislation. Such other legislation generally operates when a building is brought into use and extends to cover aspects which are outside the scope of the Building Regulations.

The main legislation in this area is the Fire Services (Northern Ireland) Order 1984 which provides for the designation of certain uses of premises and is enforced by the Fire Authority. Under that Order designated premises must be provided with means of escape in case of fire and those premises over certain limits must have their means of escape certified.

---

The Fire Authority cannot require structural or other alterations as a condition of issuing a fire certificate where plans were, in accordance with the Building Regulations, deposited with the District Council. However, where the Fire Authority is satisfied that the means of escape are inadequate by reason of matters or circumstances, particulars of which were not required to be supplied to the District Council in connection with the deposit of plans for Building Regulations purposes, then the Fire Authority is not barred from requiring such alterations.

Other legislation, such as that for entertainment licensing, is enforced by the District Council and does not contain a similar bar to that in the Fire Services Order.

## **Property protection**

**0.11** Building Regulations are intended to ensure that an adequate standard of life safety is provided in case of fire. The protection of property, including the building itself, may require additional measures and insurers will in general seek their own measures if they are to accept the insurance risk. Such measures (e.g. locking doors on escape routes) must not negate or reduce the level of protection or performance of any provision in this Technical Booklet.

# Section 1 – Means of escape

**1.1** The provisions in this Section have been formulated using assumptions regarding the likely source and growth of a fire and are based on recognised criteria for means of escape. These assumptions and criteria are outlined in the Foreword – see paragraph 0.3.

The provisions are divided into –

- (a)** those applying to dwellinghouses – paragraphs 1.2 and 1.23;
- (b)** those applying to all types of buildings other than dwellinghouses –
  - (i) the horizontal part of the escape route – paragraphs 1.26 to 1.42; and
  - (ii) the vertical part of the escape route – paragraphs 1.43 to 1.58; and
- (c)** general provisions applying to dwellinghouses and all other types of buildings – paragraphs 1.59 to 1.75.

## Dwellinghouses

### Introduction

**1.2** The provisions for means of escape in typical one and two storey dwellinghouses (i.e. those with no storey more than 4.5 m above ground level) are limited to those given in paragraphs 1.3 to 1.6.

With increasing height additional provisions are necessary as stairs may become impassable before evacuation is complete. The additional provisions are given in paragraphs 1.7 to 1.10.

Where an external escape route is provided the provisions contained in paragraphs 1.41, 1.42 and 1.58 shall also apply.

### General provisions

**1.3** Every storey (including a basement storey) in a dwellinghouse which does not have alternative escape routes leading to their own exits shall have an openable window, complying with paragraph 1.6, for escape or rescue purposes.

**1.4** A habitable room shall open directly onto a hallway (including a corridor or landing leading to the hallway) which leads to the entrance without passing through any room (except a porch), other than where the habitable room –

- (a)** has an alternative escape route;

- (b)** is on a storey not more than 4.5 m above ground level and the habitable room has an openable window complying with paragraph 1.6; or

- (c)** is part of a roof space conversion which complies with paragraphs 1.11 to 1.16.

### Access rooms to inner rooms

**1.5** A habitable room may be an access room to any inner room. A kitchen shall not be an access room to an inner room other than –

- (a)** to a utility room or conservatory which has an openable window complying with paragraph 1.6; or
- (b)** where the kitchen is part of an alternative escape route.

### Openable windows for escape or rescue

**1.6** An openable window for escape or rescue purposes shall –

- (a)** have a clear opening that is at least 850 mm high and 500 mm wide. The lower edge of the window opening shall be not less than 800 mm and not more than 1100 mm above the floor except in the case of a roof window where the lower edge of the window opening may be not less than 600 mm above the floor;
- (b)** where practicable – be located remote from the primary escape route; and
- (c)** not lead to an enclosed yard or garden unless it has an area of relative safety which is not less than the height of the dwellinghouse from the dwellinghouse. An enclosed yard or garden is one from which there is no exit under the control of the occupants of the dwellinghouse.

Where the openable window is from an upper storey that window shall be located to facilitate rescue by ladder from the ground.

Where the openable window is a dormer or roof window it shall be positioned as shown on Diagram 1.1.

For the purposes of this paragraph an openable window shall be taken to include a door which leads to an area (e.g. a balcony) from which a person could be rescued. The minimum height to the lower edge of the opening, given in sub-paragraph (a), shall not apply to such a door.

### Additional provisions for a dwellinghouse with one storey more than 4.5 m above ground level

1.7 In a dwellinghouse with only one storey more than 4.5 m above ground level –

- (a) the top storey shall –
  - (i) be separated from the lower storeys by fire-resisting construction; and
  - (ii) have an alternative escape route leading to its own final exit; or
- (b) all storeys above the storey containing the final exit shall be served by a protected stairway which either –
  - (i) extends to a final exit as shown in Diagram 1.2(a); or
  - (ii) leads to at least two escape routes at ground level, each leading to a final exit and separated from each other by fire-resisting construction and self-closing fire doors as shown in Diagram 1.2(b).

1.8 Where the storey which is more than 4.5 m above ground level is created by the conversion of the roof space of a one or two storey dwellinghouse the provisions of paragraphs 1.11 to 1.16 may be applied as an alternative to the provisions of paragraph 1.7.

### Additional provisions for a dwellinghouse with two or more storeys more than 4.5 m above ground level

1.9 In a dwellinghouse with two or more storeys more than 4.5 m above ground level –

- (a) all storeys above the storey containing the final exit shall be served by a protected stairway which complies with paragraph 1.7(b); and
- (b) each storey that is over 7.5 m above ground level shall have an alternative escape route leading to its own final exit. Where access to an alternative escape route is through the protected stairway, the protected stairway shall be subdivided by fire-resisting construction at or about 7.5 m above ground level.

**Diagram 1.1 Escape windows from roof space conversions**

see para 1.6 and 1.16(b)

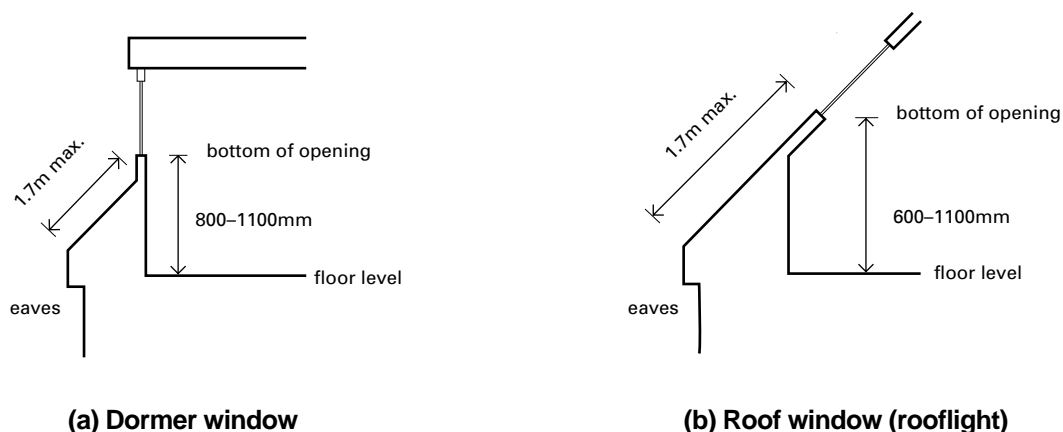

**Note**

Clear window opening at least 850mm high by 500mm wide.  
The window may be in the end wall of the dwellinghouse instead of the roof as shown.

---

## Ducted warm air heating systems

**1.10** In a dwellinghouse with a storey more than 4.5 m above ground level, any system of ducted warm air heating shall –

- (a) not be fitted with transfer grilles between any room and a protected stairway;
- (b) not have supply and return grilles more than 450 mm above floor level;
- (c) where warm air is ducted to a protected stairway – have the return air ducted back to the heater;
- (d) where a duct passes through the enclosure to a protected stairway – have the joints between the duct and the enclosure fire stopped; and
- (e) have a thermal cut out with maximum setting of 35°C, which turns off the heater and any circulation fan if the ambient temperature exceeds that setting.

## Roof space conversions

**1.11** Where a roof space is to be converted to habitable accommodation either –

- (a) the relevant provisions of paragraphs 1.3 to 1.10 shall apply; or
- (b) where the existing dwellinghouse has two storeys the provisions in paragraphs 1.12 to 1.16 may be followed provided that the new storey does not –
  - (i) exceed 50 m<sup>2</sup> in area; or
  - (ii) contain more than two habitable rooms.

## Enclosure of existing stairway

**1.12** The existing stairway shall be enclosed by fire-resisting walls and either –

- (a) extend to a final exit as shown in Diagram 1.2(a); or
- (b) lead to at least two escape routes at ground level, each delivering to a final exit and separated from each other by fire-resisting construction and self-closing fire doors as shown in Diagram 1.2(b).

**1.13** Any glazing in the enclosure of the existing stairway, other than to a bathroom or sanitary accommodation, shall be fire-resisting.

**1.14** Other than where paragraph 1.12 requires a fire door, every doorway in the enclosure to the existing stairway shall be fitted with an imperforate door. A door to a habitable room shall be fitted with a self-closing device.

Where a new door is to be provided to an existing habitable room it shall be a fire door.

## Fire separation of new storey

**1.15** The new storey shall be separated from the rest of the dwellinghouse by fire-resisting construction. The new stairway shall either –

- (a) rise as a continuation of the existing stairway and enclosure, in which case the stairway shall be separated from the new accommodation by fire-resisting construction; or
- (b) be separated from the existing stairway and the rest of the dwellinghouse by fire-resisting construction.

Any door in new fire-resisting construction shall be a self-closing fire door.

**1.16** Each habitable room in the new storey shall have –

- (a) an openable window which complies with paragraph 1.6; or
- (b) an openable dormer window or roof window, of the size given in paragraph 1.6 located as shown in Diagram 1.1.

## Automatic fire detection in dwellinghouses

**1.17** A dwellinghouse shall be provided with either –

- (a) a self-contained smoke alarm or alarms complying with BS 5446: Part 1: 1990 installed in accordance with paragraphs 1.18 to 1.23; or
- (b) an automatic fire detection and alarm system complying with BS 5839: Part 1: 1988 of at least L3 standard.

However, in a very large dwellinghouse (where the shortest route from any point in one room to the furthest point in any other room on the same storey is more than 30m) self-contained smoke alarms are not adequate and an automatic fire detection and alarm system shall be fitted.

## Diagram 1.2 Alternative arrangements for final exits

see para 1.7(b) and 1.12(a) & (b)

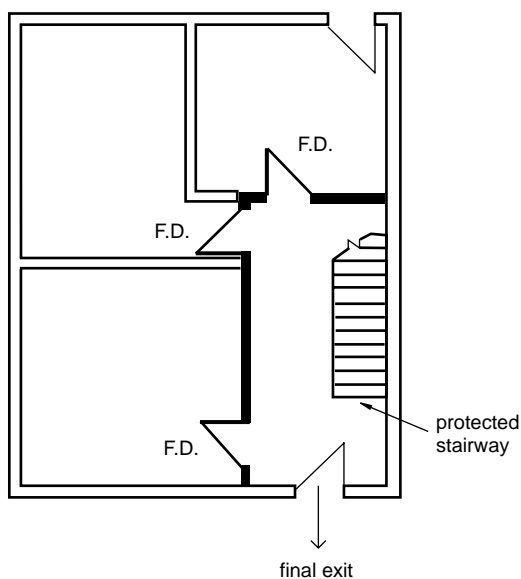

(a) Protected stairway delivering directly to the final exit

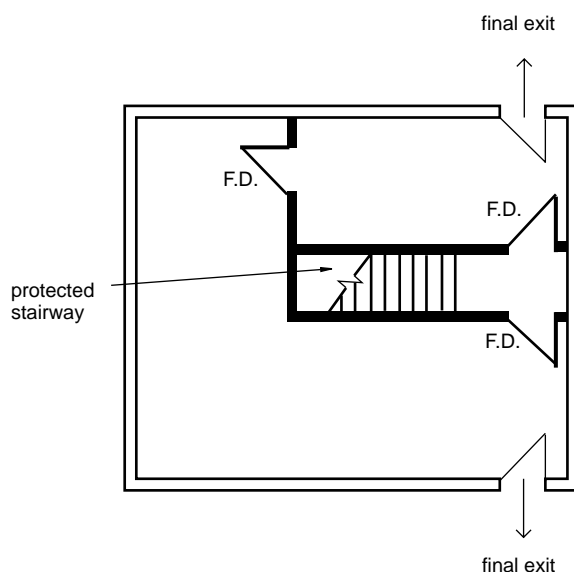

(b) Protected stairway affording access to two independent escape routes

### Key

- F.D. fire-resisting door  
 fire-resisting construction

## Provision of self-contained smoke alarms

**1.18** At least one self-contained smoke alarm shall be provided on each storey and the alarm or alarms shall be located to comply with the provisions of paragraphs 1.20 to 1.22.

Where a dwellinghouse has more than one self-contained smoke alarm the alarms shall be interconnected so that they all give an audible alarm when any one of them detects smoke.

The maximum number of self-contained smoke alarms which may be interconnected shall not exceed that given in the manufacturer's instructions.

## Installation of self-contained smoke alarms

**1.19** Self-contained smoke alarms shall be permanently wired to a circuit which –

- (a) is separately fused at the distribution board;
  - (b) serves only self-contained smoke alarms;
- and

(c) where a residual current device is used – is not connected to a residual current device which is also used by any other circuit.

Self-contained smoke alarms may operate at a low voltage via a mains transformer. The cable for the power supply to, and interconnection of, the smoke alarms need not have special fire-survival properties.

---

**1.20** Self-contained smoke alarms shall be located in the circulation route or routes of a dwellinghouse so that there is one –

**(a)** not more than 3 m from every bedroom door;

**(b)** not more than 7 m from every door to a living room or kitchen; and

**(c)** where a circulation route on a storey is more than 15 m long – not more than 15 m from another self-contained smoke alarm on the same circulation route and storey.

**1.21** A self-contained smoke alarm shall be located so that it is –

**(a)** either on a ceiling and not less than 300 mm from a wall or light fitting, or where designed for wall mounting on a wall and not less than 150 mm, or more than 300 mm from the ceiling;

**(b)** not less than 300 mm from, and not directly above, a heater or an air conditioning ventilator;

**(c)** on a surface which is normally at the ambient temperature for the space it bounds; and

**(d)** easily and safely accessible.

**1.22** A self-contained smoke alarm shall not be located in a kitchen, garage or other place where steam, condensation or fumes could give false alarms.

**1.23** Where dwellinghouses are part of a sheltered dwelling scheme with a warden or supervisor, a self-contained smoke alarm within each dwellinghouse shall be connected to the warden's or supervisor's central monitoring point so as to –

**(a)** give an audible warning of the detection of smoke in any dwellinghouse; and

**(b)** enable the identification of the dwellinghouse involved.

---

## Buildings other than dwellinghouses

**1.24** In buildings other than dwellinghouses the number of escape routes needed depends on the number of occupants (occupant capacity). In some cases a room or a storey is designed to accommodate a known number of people; in others the occupant capacity shall be calculated by dividing the area of the room or storey (excluding stairways, lifts and sanitary accommodation) by the appropriate floor space factor given in Table 1.1. Where the occupant capacity is calculated for rooms the occupant capacity of a storey is the sum of the occupant capacities of the rooms on that storey. The occupant capacity of a building or part of a building is the sum of the occupant capacities of the storeys in that building or part.

**1.25** Where a building contains areas in different purpose groups the means of escape from any area which is of Purpose Group 1(a), 2 or 5 shall be independent of the means of escape from other areas of the building.

### Horizontal part of the escape route

**1.26** The provisions in paragraphs 1.27 to 1.42 relate to horizontal escape routes leading to storey exits. They are mainly concerned with providing more than one escape route (except in the circumstances described in paragraph 1.27), limiting the distance to be travelled, and ensuring that the routes are of adequate width.

### Single escape routes

**1.27** Alternative escape routes shall be provided from all parts of the building other than in the following circumstances where a single route is permitted –

**(a)** areas from which a storey exit can be reached within the maximum travel distance in one direction only given in Table 1.2, provided that no room in this situation has an occupant capacity of more than 50 people, or 30 people if the building is an Institution [Purpose Group 2(a)]; and

**(b)** a storey with an occupant capacity of no more than 50 people, provided that a storey exit can be reached within the maximum travel distance in one direction only given in Table 1.2.

### Travel distance

**1.28** Whether there are alternative escape routes or only a single one, the travel distance to the nearest storey exit shall not exceed the maximum relevant travel distance given in Table 1.2.

Where the initial part of an escape route is in one direction only (e.g. as shown in Diagram 1.3 where there is one escape route from a room to a corridor, from which point escape is possible in two directions), that part shall not exceed the maximum travel distance in one direction only, and the overall travel distance shall not exceed the maximum travel distance in more than one direction.

### Number of escape routes and exits

**1.29** The number of escape routes and exits shall not be less than the number given in Table 1.3 for the relevant occupant capacity of the room or storey as appropriate. The escape routes and exits shall be arranged such that the travel distances given in Table 1.2 are not exceeded.

**Table 1.1 Floor space factors**

Item	Type of accommodation <sup>(1)(2)</sup>	Floor space factor m <sup>2</sup> /person
1	Standing spectator areas	0.3
2	Amusement arcade, assembly hall (including a general purpose place of assembly) bar (including a lounge bar), bingo hall, dance floor or hall, club, crush hall, venue for pop concert and similar events, queuing area	0.5
3	Concourse (other than in a shopping complex) <sup>(3)</sup>	0.75
4	Committee room, common room, conference room, dining room, licensed betting office (public area), lounge (other than lounge bar), meeting room, reading room, restaurant, staff room, waiting room	1.0 <sup>(4)</sup>
5	Exhibition hall	1.5
6	Shop sales area <sup>(5)</sup> , skating rink	2.0
7	Art gallery, dormitory, factory production area, office (open-plan exceeding 60 m <sup>2</sup> ), workshop	5.0
8	Kitchen, library, office (other than in 7 above), shop sales area <sup>(6)</sup>	7.0
9	Bedroom or study-bedroom	8.0
10	Bed-sitting room, billiards room	10.0
11	Storage and warehouse accommodation	30.0
12	Car park	Two people per parking space

**Notes –**

- (1) Where accommodation is not directly covered by the descriptions given, a reasonable value based on a similar use may be selected.
- (2) If there is to be mixed use, the most onerous factor should be applied.
- (3) The deemed-to-satisfy provision given in regulation E3 (i) for shopping complexes is BS 5588: Part 10: 1991.
- (4) Alternatively, the occupant capacity may be taken as the number of fixed seats provided, if the occupants will normally be seated.
- (5) Shops, other than those included under item 8, including – supermarkets and department stores (all sales areas), shops for personal services such as hairdressing and shops for the delivery or collection of goods for cleaning, repair or other treatment or for members of the public themselves carrying out such cleaning, repair or other treatment.
- (6) Shops, excluding those in covered shopping complexes and department stores, trading predominantly in furniture, floor coverings, cycles, perambulators, large domestic appliances or other bulky goods, or trading on a wholesale self-selection basis (cash and carry).

**Table 1.2 Limitations on travel distances**

Purpose group	Use of the building or part of the building	Maximum travel distance <sup>(1)</sup> where travel is possible in –	
		One direction only (m)	More than one direction (m)
2(a)	Institutional	9	18
2(b)	Other residential –		
	(a) in bedrooms	9 <sup>(2)</sup>	18 <sup>(2)</sup>
	(b) in bedroom corridors	9	35
	(c) elsewhere	18	35
3	Office	18	45
4	Shop and commercial	18	45
5	Assembly and recreation –		
	(a) buildings primarily for the handicapped (except schools)	9	18
	(b) elsewhere	15	32
6	Industrial <sup>(3)</sup>	25	45
7	Storage and other non-residential <sup>(3)</sup>	18	45
2, 3, 4, 5, 6 and 7	Place of special fire risk <sup>(4)</sup>	9 <sup>(2)</sup>	18 <sup>(2)</sup>
2, 3, 4, 5, 6 and 7	Plant room or rooftop plant –		
	(a) distance within the room	9	35
	(b) escape route not in open air (overall travel distance)	18	45
	(c) escape route in open air (overall travel distance)	60	100

**Notes –**

- (1) The dimensions in the Table are travel distances. If the internal layout of partitions, fittings, etc. is not known when plans are deposited, direct distances may be used for assessment. The direct distance shall be taken as two-thirds of the travel distance.
- (2) Maximum part of travel distance within the room.
- (3) In industrial buildings the appropriate travel distance depends on the level of fire risk associated with the processes and materials being used.  
The dimensions given above assume that the building will be of normal fire risk. If the building is high risk, then lesser distances of 12 m in one direction and 25 m in more than one direction, shall apply.
- (4) Places of special fire risk are listed in the definitions in paragraph 6.6.

**Table 1.3 Number of escape routes and exits**

Maximum occupant capacity	Minimum number of escape routes/exits
500	2 <sup>(1)</sup>
1000	3
2000	4
4000	5
7000	6
11000	7
16000	8
More than 16000	8 <sup>(2)</sup>

**Notes –**

(1) See paragraph 1.27 for the circumstances in which single exits and escape routes are acceptable.

(2) Plus 1 per 5000 people (or part thereof) over 16000.

**Alternative escape routes**

**1.30** To prevent alternative escape routes being simultaneously unusable they shall either –

- (a) be 45° or more apart (see Diagram 1.4); or
- (b) if less than 45° apart be separated from each other by fire-resisting construction.

**Inner rooms**

**1.31** An inner room is only permitted where –

- (a) the number of occupants of the inner room is not more than 50 people (or in the case of a building in Purpose Group 2(a), 30 people);
- (b) is not a bedroom;
- (c) the escape route from the inner room does not pass through more than one access room;
- (d) the distance from any point in the inner room to the nearest exit from the access room does not exceed the appropriate maximum travel distance in one direction only given in Table 1.2;
- (e) the access room is not a place of special fire risk and is in the control of the same occupier as the inner room; and

(f) one of the following applies –

(i) that part of the enclosure separating the inner and access room is stopped at least 500 mm below the ceiling;

(ii) a vision panel of not less than 0.1 m<sup>2</sup> is provided in the enclosure to the inner room so that a fire in the access room will be visible from the inner room at an early stage; or

(iii) the access room is fitted with a suitable automatic detection and alarm system to warn the occupants of the inner room of the outbreak of a fire in the access room.

### Diagram 1.3 Travel distance in single direction leading to alternative escape routes

see para 1.28

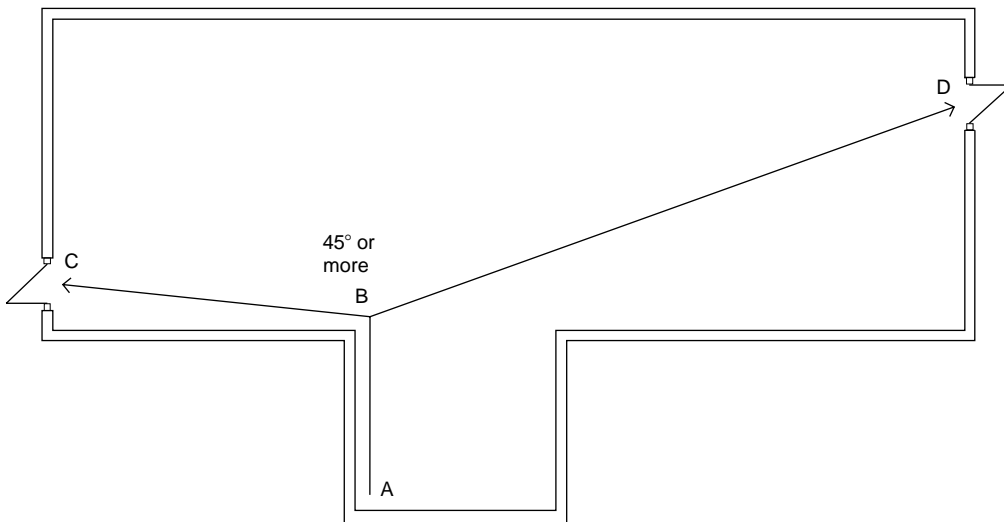

If angle CBD is  $45^\circ$  or more alternative escape routes are available from B provided either AC or AD is less than or equal to the maximum travel distance in more than one direction and AB is less than or equal to the maximum travel distance in one direction only.

### Diagram 1.4 Alternative escape routes

see para 1.30(a)

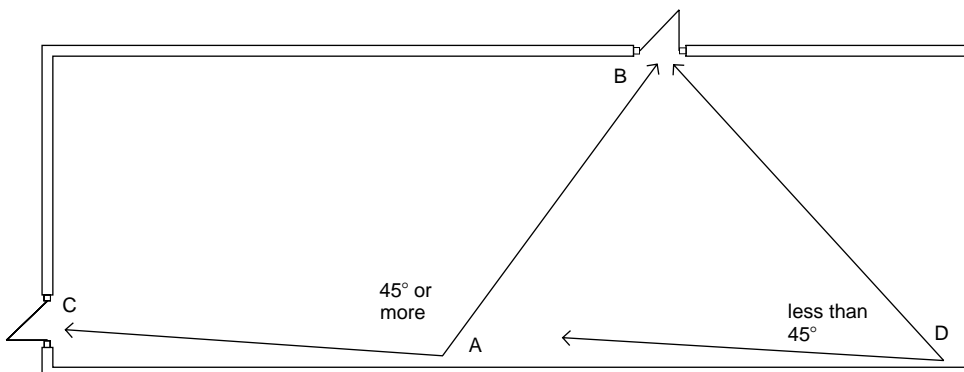

Acceptable alternative escape routes are available from A (so that either AB or AC is less than or equal to the maximum travel distance in more than one direction) but not from D.

## Access to storey exits

**1.32** In any storey which has more than one escape stairway the escape routes shall be arranged so that people do not have to pass through one stairway to reach another. However, it is acceptable to pass through the protected lobby of one stairway to reach another escape stairway.

## Separation of circulation routes from escape stairways

**1.33** A protected stairway shall not form part of the primary circulation route between different parts of the building at the same level. However, it is acceptable for a protected lobby to form part of the primary circulation route.

## Open spacial planning

**1.34** Escape routes shall not be prejudiced by open connections between floors such as at an escalator.

An escape route shall not be within 5 m of the open connection unless –

- (a) the direction of travel is away from the opening; or
- (b) there is an alternative escape route which does not pass within 5 m of the open connection.

See Diagram 1.5.

## Planning of storey exits in a central core

**1.35** A building with more than one storey exit in a central core shall be planned so that the storey exits are remote from each other and not linked by a lift hall, lobby, or undivided corridor.

Where the central core is separated from the accommodation by a corridor, the corridor shall be subdivided by self-closing fire doors (and any necessary associated screens) so that the storey exits are separated as in Diagram 1.6.

## Storeys divided into different occupancies

**1.36** Where a storey is divided into two or more occupancies (i.e. ownerships, tenancies or similar) the means of escape from one occupancy shall not pass through any other occupancy.

However, where the means of escape includes a corridor common to two or more occupancies then either it shall be a protected corridor, or a fire detection and alarm system to BS 5839: Part 1: 1988, of at least L3 standard, shall be installed.

## Width of escape routes and storey exits

**1.37** The width of an escape route or storey exit shall be not less than the minimum width, given in Table 1.4, for the appropriate number of people assessed as being likely to use it. There shall be no projections into escape routes and storey exits other than door frames and handrails with a projection of less than 100 mm. (Note – for the purposes of Part H stair widths are measured between handrails.)

Where there is a single escape route and storey exit their capacity shall be not less than the number of occupants of the storey.

Where two or more escape routes and storey exits are provided it shall be assumed that one of them may not be available due to fire or smoke. Therefore, each storey exit in turn shall be discounted in order to ensure that the capacity of the remaining storey exits is adequate for the total number of people needing to use them.

**Table 1.4 Widths of escape routes and storey exits**

Maximum number of people <sup>(1)</sup>	Minimum width mm
50	800 <sup>(2)</sup>
110	900
220	1100
More than 220	5 per person

### Notes –

- (1) Assessed as being likely to use the escape route or storey exit.
- (2) May be reduced to 530 mm for gangways between fixed storage racking, other than in public areas in Purpose Group 4 buildings.

## Diagram 1.5 Escape routes in relation to open connections between floors

see para 1.34

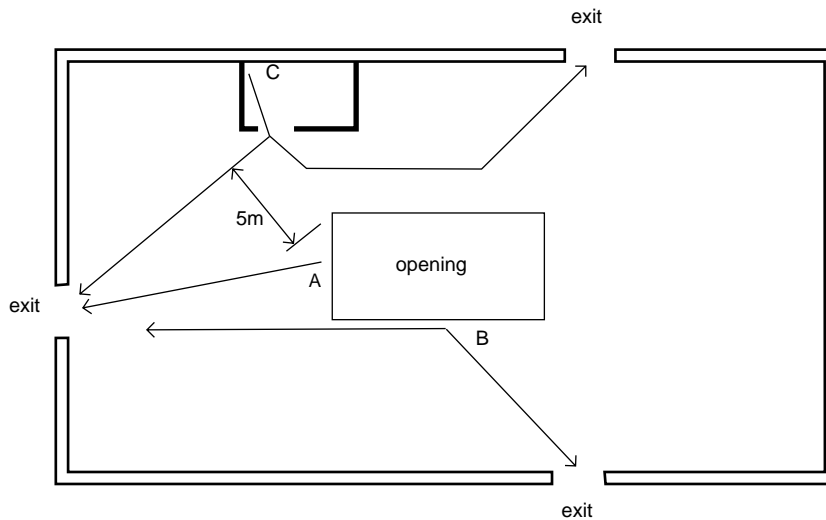

From A and B at least one direction of travel is away from the opening. From C where the initial direction of travel is towards the opening one of the escape routes is not less than 5m from the opening.

## Diagram 1.6 Storey exits in a central core

see para 1.35

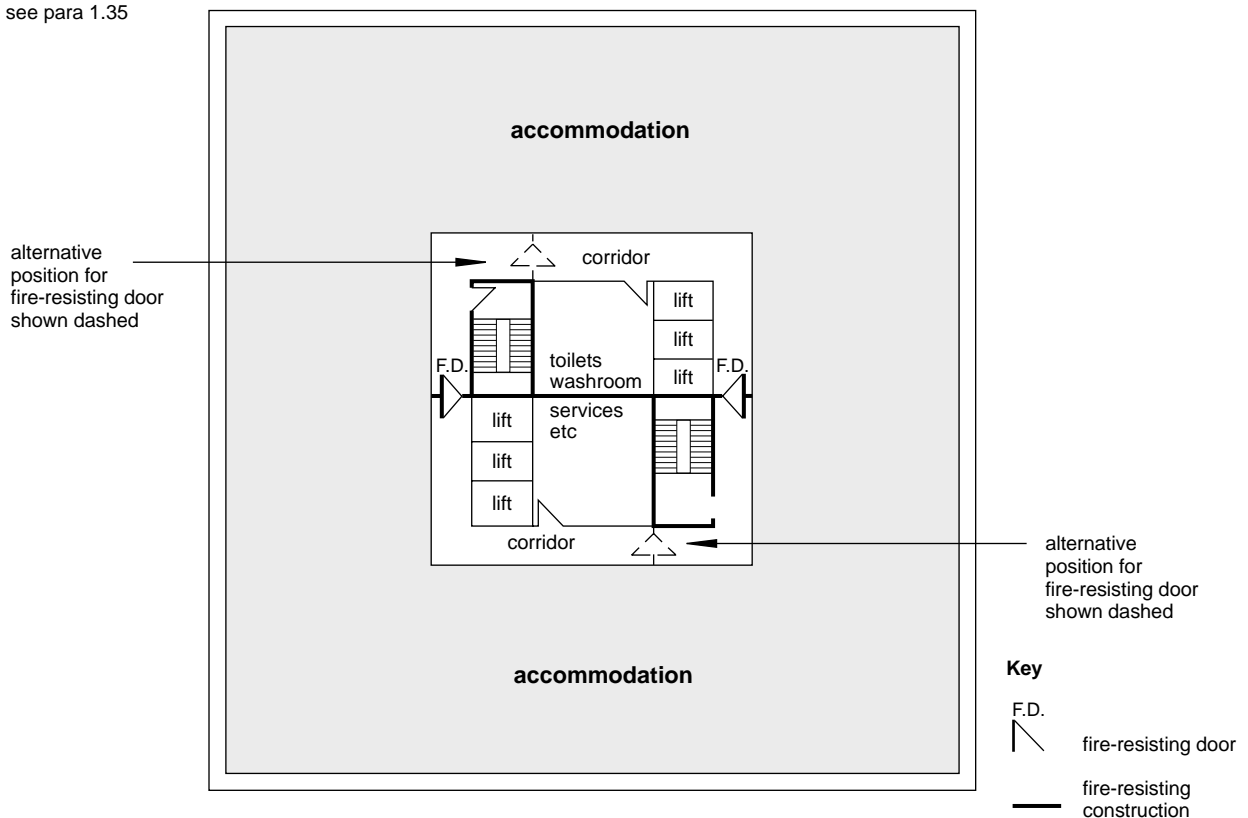

---

### Protected corridors

**1.38** A corridor that is part of the means of escape shall be a protected corridor where it is –

- (a) within residential accommodation;
- (b) a corridor from which escape is in one direction only (i.e. a dead end corridor); or
- (c) common to two or more different occupancies other than where a fire detection and alarm system is installed in accordance with paragraph 1.36.

### Subdivision of corridors

**1.39** Where a corridor exceeding 12 m in length connects two or more storey exits, it shall be subdivided by self-closing fire doors (and any necessary associated fire-resisting screens) so that no undivided part is common to two or more storey exits. For corridors around a central core see paragraph 1.35.

Where a dead end portion of a corridor exceeding 4.5 m in length leads to a point where alternative escape routes are available, the dead end portion shall be extended and separated by self-closing fire doors (and any necessary associated fire-resisting screens) from the remainder of the corridor as shown in Diagram 1.7. However, where the stairways and corridors are protected by a pressurization system complying with BS 5588: Part 4: 1978, such separation is not necessary.

### Enclosure of corridors that are not protected corridors

**1.40** Where a corridor which is part of an escape route, but is not a protected corridor, is enclosed by partitions, those partitions shall be carried up to the underside of the structural floor or to a suspended ceiling. In the latter case cavity barriers shall be provided in accordance with paragraph 3.27. Every opening into a room shall be fitted with a door.

### External escape routes

**1.41** Where an external escape route, other than a stair, is beside an external wall of the building, that part of the external wall within 3 m (measured horizontally) of the escape route shall be of fire-resisting construction 1.8 m above and 9 m below the level of the route as shown in Diagram 1.9 (see page 27).

### Escape over flat roofs

**1.42** Where more than one escape route is available from a storey, (or part of a building where appropriate) one of those routes may be by way of a flat roof, provided that –

- (a) the route does not serve –
  - (i) a building of Purpose Group 2(a); or
  - (ii) in a building of any other purpose group – an area intended for use by members of the public;
- (b) the flat roof is part of the same building from which escape is being made;
- (c) the route across the flat roof leads to an escape stair;
- (d) the part of the flat roof forming the escape route and its supporting structure, together with any opening in the roof within 3 m of the escape route, is fire-resisting; and
- (e) the route is defined and guarded by walls and/or protective barriers which comply with Part H.

**Diagram 1.7 Dead-end corridors**

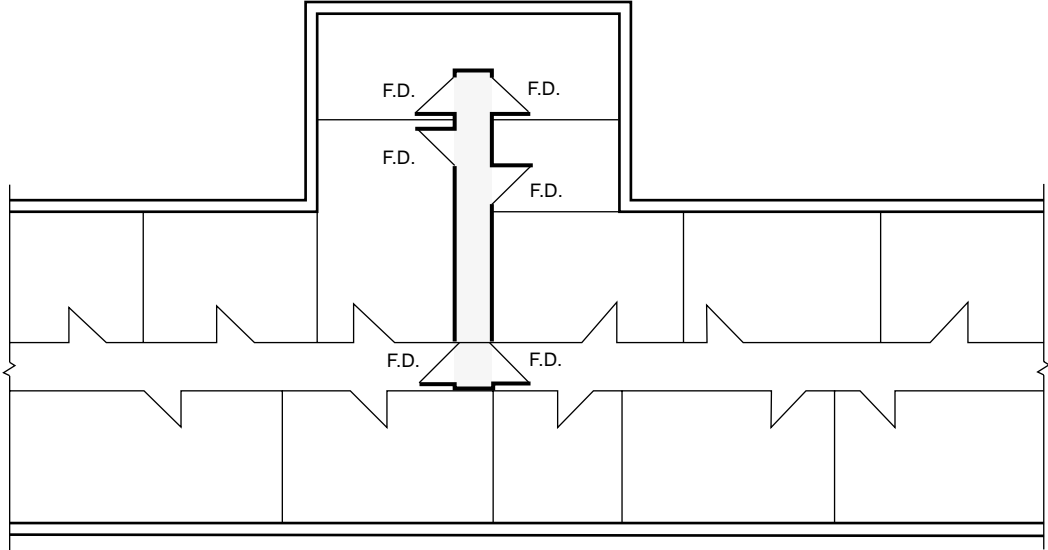

see para 1.39

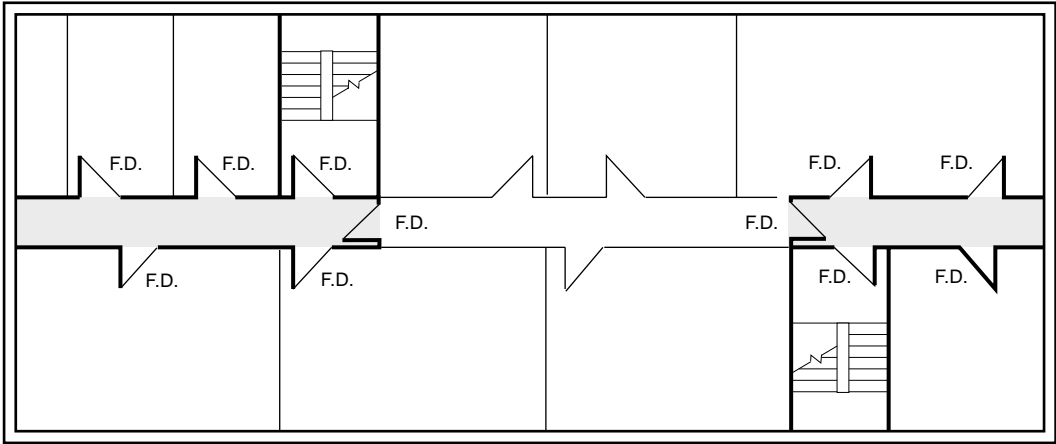

**(a) T-junction with main corridor**



**(b) Continuation past stairway**

- Key**
-  F.D. fire-resisting door
  -  fire-resisting construction
  -  protected corridor

---

## Vertical part of the escape route

**1.43** The provisions in paragraphs 1.44 to 1.58 relate to the vertical escape down or up escape stairways towards a final exit. They are mainly concerned with providing a sufficient number of escape stairs of adequate aggregate width and their protection.

### Number of escape stairways

**1.44** The number of escape stairways in a building, or part of a building is determined by the provisions in –

- (a) paragraph 1.25 regarding independent escape routes from areas in certain uses;
- (b) paragraphs 1.27 and 1.29 regarding the design of the horizontal part of the escape route;
- (c) paragraphs 1.46 and 1.47 regarding the width of stairs and the discounting of a stairway respectively; and
- (d) Section 5 regarding the provision and location of firefighting stairways.

### Single escape stairways

**1.45** Where independent escape routes are not required from areas in different purpose groups, in accordance with paragraph 1.25, a single escape stairway may serve –

- (a) a basement which is permitted to have a single escape route in accordance with paragraph 1.27; or
- (b) a building which has no storey with a floor level more than 10 m above ground level, and in which every storey is permitted to have a single escape route in accordance with paragraph 1.27.

### Width of escape stairs

**1.46** an escape stair shall be wide enough to accommodate the appropriate number of people assessed as being likely to use it.

This width will depend on the number of stairways provided and whether the escape strategy is based on the total evacuation (see paragraph 1.48) or phased evacuation (see paragraph 1.49).

In any event an escape stair shall –

- (a) be not less than the appropriate dimension given in Table 1.5;

- (b) be not less than the width required for any storey exit giving access to it;

- (c) not reduce in width at any point on its way to the final exit; and

- (d) not exceed 1400 mm if the vertical extent of the escape stair is more than 30 m, unless it is at least 1800 mm and it is provided with a central handrail. In such a case the width on each side of the handrail shall be considered separately for the purpose of assessing stair capacity.

### Discounting of escape stairways

**1.47** Whether total or phased evacuation is used, where two or more escape stairways are provided it shall be assumed that one of them may not be available due to fire or smoke. Therefore, each stairway in turn shall be discounted in order to ensure that the capacity of the remaining stairways is adequate for the total number of people needing to use them.

This discounting provision need not be applied where –

- (a) the escape stairways are approached on each storey (except the topmost storey), through a protected lobby; or
- (b) the escape stairways are protected by pressurization systems designed in accordance with BS 5588: Part 4: 1978.

### Total evacuation

**1.48** In a building or part of a building designed for total evacuation the escape stairways shall have the capacity to allow all floors to be evacuated simultaneously and a suitable fire alarm system to BS 5839: Part 1: 1988, shall be installed.

Total evacuation shall be used for –

- (a) a basement;
- (b) a building containing open spacial planning;
- (c) a building of Purpose Group 2; and
- (d) a building of Purpose Group 5.

**Table 1.5 Minimum width of escape stairs**

Situation of stair	Maximum number of people served <sup>(1)</sup>	Minimum stair width (mm)
1 In a Purpose Group 2(a) building (unless it will only be used by staff)	150	1000
2 In a Purpose Group 5 building and serving an area used for assembly purposes (unless the area is less than 100 m <sup>2</sup> )	220	1100
3 In a building of any other purpose group and serving an area with an occupancy of more than 50	Over 220	Note (2)
4 Any stair not described above	50	800

**Notes –**

- (1) Assessed as likely to use the stair in a fire emergency.
- (2) See Table 1.6 for sizing stairs for total evacuation and Table 1.7 for phased evacuation.

Where total evacuation is to be used the capacity of an escape stairway shall be either –

**(i)** in a building of not more than 10 storeys and for basements – that given for the appropriate width of escape stairs in Table 1.6; or

**(ii)** in a building of more than 10 storeys – that derived from the formula

$$P = 200w + 50 (w - 0.3)(n - 1),$$

where P = the number of people that can be accommodated;

w = the width of the escape stair (in metres); and

n = the number of storeys served by the stair.

**Phased evacuation**

**1.49** In certain buildings it may be advantageous to design the escape stairways on the concept of phased evacuation. With phased evacuation the first people to be evacuated are those on the floor of the fire and the floor above together with those in the building who have reduced mobility.

Subsequently, if there is a need to evacuate more people, it shall be done two floors at a time.

In such a building, or part of a building –

**(a)** every escape stairway shall be approached through a protected lobby or protected corridor at each storey, other than at a top storey consisting exclusively of plant rooms;

**(b)** every floor shall be a compartment floor;

**(c)** an automatic sprinkler system complying with the relevant recommendations of BS 5306: Part 2: 1990, shall be installed throughout the building where the building has a storey more than 30 m above ground level;

**(d)** an automatic fire detection and alarm system, to BS 5839: Part 1: 1988, of at least L3 standard, shall be installed;

**(e)** a public address system shall be installed throughout the building, or part of the building; and

**(f)** an internal speech communication system, such as a telephone or intercom, shall be installed between a control point at fire access level (see Section 5) and every storey.

The systems provided to meet (d) and (e) above, and any similar systems provided elsewhere in the building, shall have control facilities to ensure satisfactory separate or combined operation of any or all systems.

The minimum width of a stair for phased evacuation shall be that given in Table 1.7 for the appropriate maximum number of people on the most heavily occupied storey.

**Table 1.6 Capacity of escape stairways for total evacuation**

Number of floors served	Maximum number of people accommodated on one stair of width								
	1000 mm	1100 mm	1200 mm	1300 mm	1400 mm	1500 mm	1600 mm	1700 mm	1800 mm
1	150	220	240	260	280	300	320	340	360
2	190	260	285	310	335	360	385	410	435
3	230	300	330	360	390	420	450	480	510
4	270	340	375	410	445	480	515	550	585
5	310	380	420	460	500	540	580	620	660
6	350	420	465	510	555	600	645	690	735
7	390	460	510	560	610	660	710	760	810
8	430	500	555	610	665	720	775	830	885
9	470	540	600	660	720	780	840	900	960
10	510	580	645	710	775	840	905	970	1035

**Table 1.7 Minimum width of escape stairs for phased evacuation**

Maximum number of people in any storey <sup>(1)</sup>	Stair width <sup>(2)</sup> mm
100	1000
120	1100
130	1200
140	1300
150	1400
160	1500
170	1600
180	1700
190	1800

**Notes –**

- (1) Where the number of people (P) on the most heavily occupied storey is more than 190, the minimum width of the escape stair (Wmm) shall be calculated from  $W = (P \times 10) - 100$ .
- (2) Where the stair serves a storey more than 30 m above ground level the width shall not exceed 1400 mm [see paragraph 1.46(d)].

---

## Protection of escape stairways

**1.50** An escape stairway requires protection in order that it may provide an area of relative safety during a fire evacuation. The provisions for protecting an internal escape stairway are given in paragraphs 1.51 to 1.55 and further provisions apply when an escape stairway penetrates a compartment floor (see paragraph 3.17) or is a firefighting stairway (see paragraphs 5.2 to 5.5).

An unprotected stairway (accommodation stairway) may form part of an internal route to a storey, exit or final exit provided that the travel distance complies with paragraph 1.28 and the number of people involved is low.

## Protected lobbies and protected corridors

**1.51** A protected lobby or protected corridor shall be provided to every escape stairway on every storey in a building other than the top storey where –

- (a) the escape stairway is the only escape stairway serving the building (or part of the building) and the building (or part of the building) has more than one storey above or more than one storey below the storey containing the final exit from the escape stairway;
- (b) the escape stairway serves a storey more than 20 m above ground level;
- (c) the building is designed for phased evacuation and the top storey consists exclusively of plant rooms; or
- (d) the discounting stairway provisions have not been used in calculating escape stair widths as permitted by paragraph 1.47.

A protected lobby shall also be provided between an escape stairway and a place of special fire risk, and that lobby shall have either not less than 0.4 m<sup>2</sup> of permanent ventilation or be protected from the ingress or smoke by a mechanical smoke control system.

## Exits from protected stairways

**1.52** Every protected stairway shall discharge either –

- (a) directly to a final exit; or
- (b) to a protected exit passageway leading only to a final exit.

Where the escape route from an escape stairway also forms the escape route from the ground and/or basement storey its width shall be increased accordingly.

## Separation of adjoining protected stairways and protected exit passageways

**1.53** Where two or more protected stairways or protected exit passageways adjoin they shall be separated by an imperforate enclosure.

## Use of space within protected stairways

**1.54** A protected stairway, other than a firefighting stairway (see Section 5), shall not contain any accommodation or services other than –

- (a) sanitary accommodation or wash rooms provided that they are not used as a cloakroom;
- (b) a lift, provided that in a building (or part of a building) with a single escape stairway the lift motor room is over the lift shaft or outside the protected stairway; and
- (c) where it is not the only protected stairway in a building (or part of a building) –
  - (i) a reception desk or enquiry office area having an area of not more than 10 m<sup>2</sup> and located at ground or access level; or
  - (ii) a cupboard formed by fire-resisting construction.

## Basement stairways

**1.55** Where an escape stairway forms part of the only escape route from an upper storey of a building (or part of a building) it shall not serve a basement storey.

Where there is more than one escape stairway from an upper storey of a building (or part of a building) at least one shall terminate at ground storey level. Other stairways may connect to a basement storey provided that they are protected at each basement level by a protected lobby or protected corridor.

## External walls adjacent to protected stairways

**1.56** Where a protected stairway projects beyond, is recessed from, or is in an internal angle of the external walls of the building – the distance between any unprotected areas (see Section 4) in the adjacent external walls of the building and an unprotected area in the external walls of the protected stairway shall be not less than 1.8 m (see Diagram 1.8).

## External escape stairs

**1.57** Where more than one escape route is available from a storey (or part of a building) one of those routes may be by way of an external escape stair provided that in the case of –

- (a) a building of Purpose Group 5 – the route is not intended for use by members of the public; or
- (b) a building of Purpose Group 2 – the route serves only staff accommodation (office or residential).

**1.58** Where an external stair is part of an escape route –



- (a) the stair shall be protected from the weather when it serves a floor or flat roof more than 6 m above ground level. The degree of protection from the weather will depend on the exposure of the stair;
- (b) all doors giving access to the stair shall be fire-resisting except at the top of any stair which leads downwards;
- (c) any part of the external walls within 1.8 m horizontally, 1.8 m above, and 9 m below the flights and landings of the stair shall be of fire-resisting construction as shown on Diagram 1.9; and
- (d) the external walls of the building within 3 m of the escape route from the bottom of the stair shall be fire-resisting to a height of 1.8 m above the escape route.

**Diagram 1.8 External walls adjacent to protected stairways**

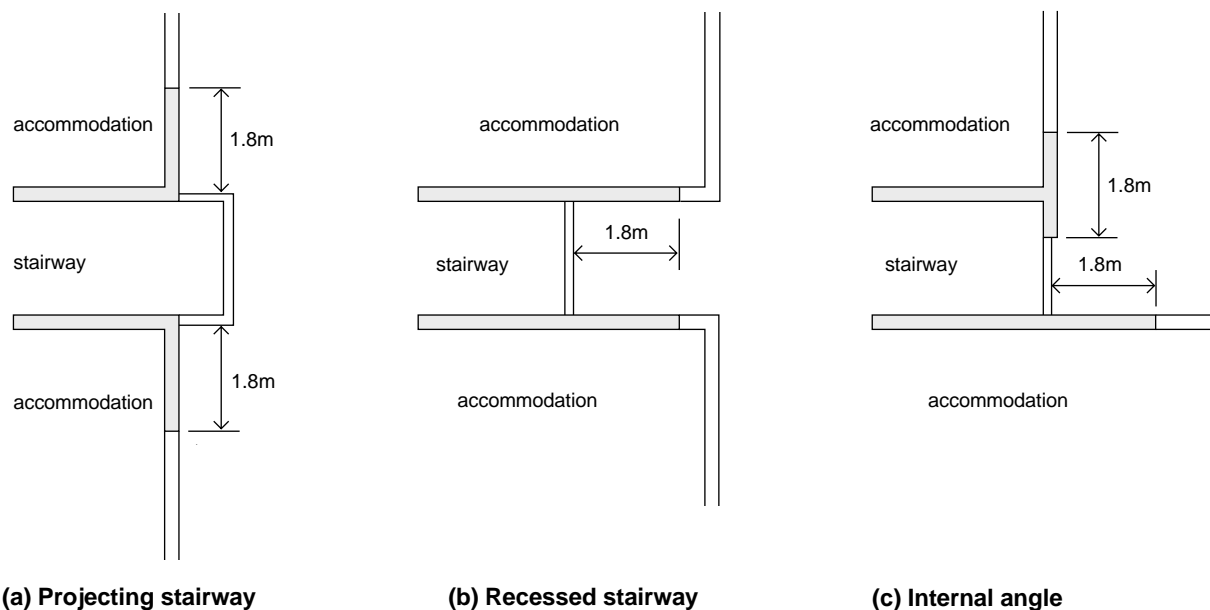
see para 1.56



### Key

-  fire-resisting walls
-  external walls which may be unprotected areas

**Diagram 1.9 Fire resistance of external walls adjacent to external escape routes**

see para 1.41 and 1.58

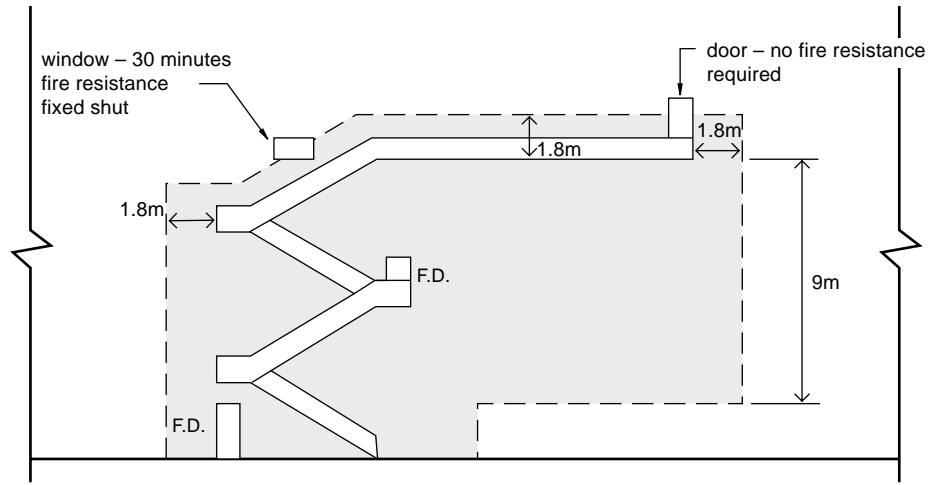

**elevation a**

**Example A**

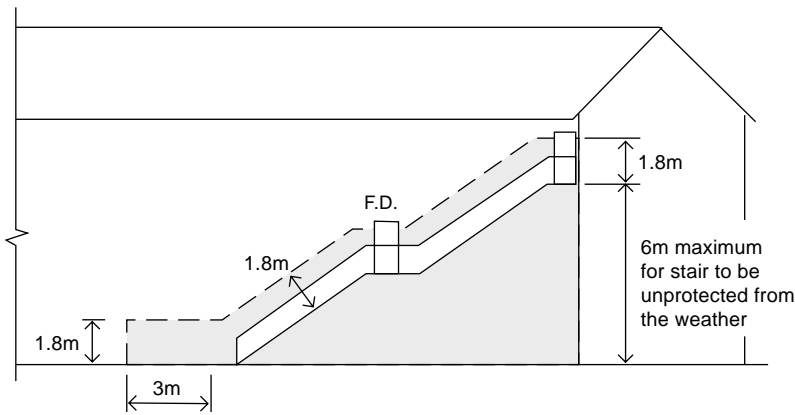

**elevation b1**

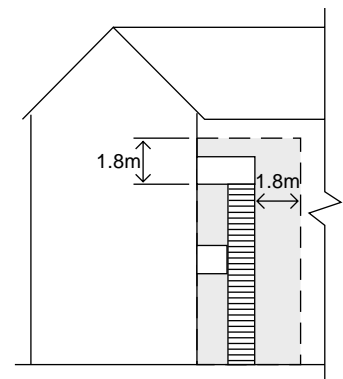

**elevation b2**

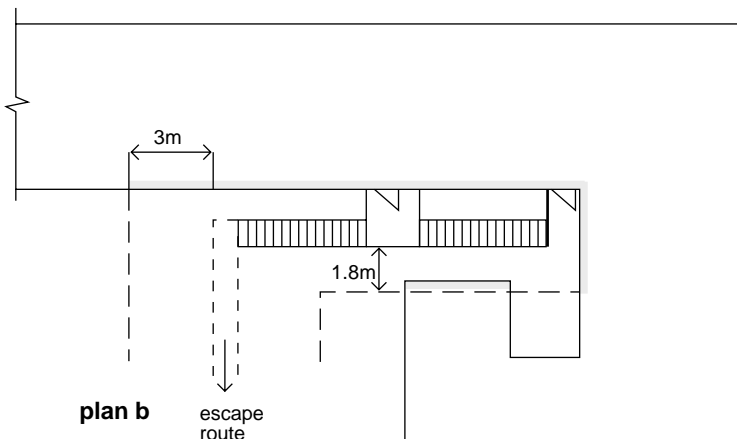

**plan b**

escape route

**Key**

- F.D. fire-resisting door
- fire-resisting area of wall

**Example B**

---

## General provisions

**1.59** The provisions in paragraphs 1.60 to 1.75 relate to the construction and protection of escape routes, some service installations and other matters associated with the design of escape routes.

### Fire resistance

**1.60** Details of fire resistance test criteria and standards of performance are given in Section 3.

All walls, partitions and other enclosures (including roofs that form part of an escape route) required to have fire resistance to meet the provisions of this Section shall have the appropriate performance given in Tables 3.1 and 3.2. Where glazed elements in such enclosures are only able to satisfy the relevant performance in respect of integrity (i.e. uninsulated glazing), their use shall be limited in accordance with Table 1.8.

All doors required to have fire resistance to meet the provisions of this Section shall have the appropriate performance given in Table 3.5, shall be self-closing and the extent of any uninsulated glazing shall be in accordance with Table 1.8.

### Seating and gangways

**1.61** Permanent or retractable seating for closely seated audiences or spectators shall be designed in accordance with Clauses 8.1 to 8.4 of BS 5588: Part 6: 1991.

### Doors on escape routes

**1.62** Doors on escape routes, whether fire doors or not, shall only be fitted with locks or fastenings which are readily operated from the side approached by a person making an escape. The operation of such a lock or fastening shall not involve the use of a key or the manipulation of more than one mechanism.

### Direction of opening of doors

**1.63** Doors on escape routes shall, as far as practicable, open in the direction of escape. Doors shall always open in the direction of escape in the following situations –

- (a) from a place of special fire risk;
- (b) in the case of a building of Purpose Group 6 or 7 – where the number of occupants is more than 10; and

(c) in the case of a building of any other purpose group – where the number of people likely to use the door in the event of a fire is more than 50.

Doors on escape routes shall open through not less than 90° and swing clear of any change in floor level, other than a threshold or single step (with a rise of not more than 180 mm) on the line of the doorway. At no point of its swing shall a door reduce the effective width of any escape route across a landing.

A door that opens towards a corridor shall be recessed to prevent its swing from encroaching on the effective width of the corridor.

**1.64** Revolving and automatic doors and turnstiles shall not be permitted across escape routes unless they –

- (a) have swing doors of the required width immediately adjacent;
- (b) are easily openable in an emergency; or
- (c) fail safely in the open position.

### Vision panels in doors

**1.65** A vision panel, of not less than 0.1 m<sup>2</sup>, shall be provided in a door that subdivides a corridor, or where a door swings both ways.

### Height and width of escape routes

**1.66** All escape routes shall have a clear headroom of not less than 2 m and there shall be no projections below this height, except for door frames.

The width of an escape route shall be measured at 1.5 m above floor level or pitch line. The projection of handrails and door frames, if less than 100 mm, and stringers, if less than 30 mm, on either or both sides shall be ignored.

The width of an escape door from a room shall be taken as the width of the door leaf or leaves.

**Table 1.8 Limitations on the use of uninsulated glazing in enclosures and fire doors on escape routes**

Position of glazed element		Permitted extent of glazing in parts of a building with access to –			
		A single stair		More than one stair	
		Walls	Door leaf	Walls	Door leaf
<b>A Purpose Group 1(b) and (c)</b>					
1	Within the enclosures of a protected stairway or within fire-resisting separation shown in Diagram 1.1	Fixed fanlights only	Unlimited	Fixed fanlights only	Unlimited
<b>B All other purpose groups</b>					
2	Between residential/sleeping accommodation and a common escape route (corridor, lobby or stair)	Nil	Nil	Nil	Nil
3	Between a protected stairway <sup>(1)</sup> and – (i) the accommodation; or (ii) a corridor which is not a protected corridor. Other than in item 2 above	Nil	25% of door area	Nil below 1.1m unlimited above 1.1m	50% of door area
4	Between – (i) a protected stairway and a protected lobby or protected corridor; or (ii) accommodation and a protected lobby. Other than in item 2 above	Nil below 1.1m unlimited above 1.1m	Nil below 0.1m unlimited above 0.1m	Nil below 0.1m unlimited above 0.1m	Nil below 0.1m unlimited above 0.1m
5	Between the accommodation and a protected corridor forming a dead end. Other than in item 2 above	Nil below 1.1m unlimited above 1.1m	Nil below 0.1m unlimited above 0.1m	Nil below 0.1m unlimited above 0.1m	Nil below 0.1m unlimited above 0.1m
6	Between accommodation and any other corridor; or subdividing corridors. Other than in item 2 above	Not applicable	Not applicable	Nil below 0.1m unlimited above 0.1m	Nil below 0.1m unlimited above 0.1m

**Notes –**

All heights shall be measured vertically from the floor, the landing level, or the stair pitch line.

- (1) If the protected stairway is also a protected shaft (see Section 3) or a firefighting stairway (see Section 5) there may be further restrictions on the uses of glazed elements.

---

## Construction of escape stairs

**1.67** Other than in a dwellinghouse every escape stair and its associated landings shall be constructed of materials of limited combustibility where –

- (a) it is the only stair serving the building (or part of the building), unless the building is of two or three storeys and is of Purpose Group 1(a);
- (b) it is within a basement storey, unless it is within a maisonette;
- (c) the height to any storey which it serves is more than 20 m above ground or final exit level;
- (d) it is a firefighting stairway (see Section 5); or
- (e) it is external, except in the case of a stair that connects the final exit level with a floor or flat roof less than 6 m above or below final exit level.

Combustible materials may be added to the upper surface of these stairs except in the case of firefighting stairways.

## Helical stairs and spiral stairs

**1.68** Where helical stairs or spiral stairs form part of an escape route they shall be designed in accordance with BS 5395: Part 2: 1984 and shall be of Type E (public stair) where they are intended to be used by the public.

## Final exits

**1.69** A final exit shall –

- (a) have a width not less than the width of the escape route it serves;
- (b) be sited to ensure rapid dispersal to a place of safety;
- (c) be readily apparent to people who need to use it; and
- (d) be sited clear of any risk from fire or smoke issuing from a basement, and from openings to transformer rooms, solid waste stores, boiler rooms and similar risks.

## Lighting of escape routes

**1.70** Other than in a dwellinghouse all escape routes shall have adequate artificial lighting. The areas listed in Table 1.9 shall also have escape lighting installed in accordance with BS 5266: Part 1: 1988 or CP 1007: 1955, which will illuminate the escape route if the mains supply fails.

Escape lighting to escape stairways shall be on a separate circuit to that supplying any other part of the escape route or building.

## Protected power circuits

**1.71** A protected power circuit shall consist of cable meeting the requirements for classification as CWZ in accordance with BS 6387: 1994. The circuit shall be separate from any circuit provided for any other purpose and shall be routed only through those areas of the building in which the fire risk is negligible.

## Exit signs

**1.72** Other than in a dwellinghouse, exits on escape routes except those in normal use for egress, shall be marked with signs which are readily visible so that the occupants of a building can clearly and readily see where the exits are.

The signs shall comply with the relevant requirements of BS 5499: Part 1: 1990.

## Fire protection of lifts

**1.73** In general, it is not appropriate to use a lift when there is a fire in the building. However, as lifts penetrate floors and are usually sited within or adjacent to circulation routes they may prejudice the means of escape from the building. To safeguard against this a lift and its associated machine room shall comply with the following provisions. (In some circumstances a suitably sited and protected lift containing certain safety features may be used for evacuating disabled people and details concerning such lifts are given in BS 5588: Part 8: 1988.)

A lift shall be –

- (a) in a protected shaft where it penetrates a compartment floor (see paragraph 3.17);
- (b) within the enclosure of a protected stairway where permitted by paragraph 1.54; or
- (c) enclosed with fire-resisting construction where its siting prejudices the means of escape.

A lift shall not be continued down to serve a basement storey in a building (or part of a building) the upper storeys of which are served by a single escape stairway or if the lift is within the enclosure to an escape stairway which is terminated at ground level.

**Table 1.9 Provisions for escape lighting**

Purpose group of the building or part of the building	Areas requiring escape lighting
Purpose Group 2	All common escape routes
Purpose Groups 3, 4 <sup>(1)</sup> , 6 and 7(a)	(a) Underground or windowless accommodation (b) Stairways in a central core or serving storey(s) more than 20 m above ground level (c) Internal corridors more than 30 m long (d) Open-plan office areas more than 60 m <sup>2</sup>
Purpose Groups 4 <sup>(2)</sup> and 7(b)	All escape routes (except in a shop of not more than three storeys, with no sales floor greater than 280 m <sup>2</sup> , provided that the shop is not a restaurant or bar)
Purpose Group 5	All escape routes and accommodation except for – (a) accommodation open on one side to view sport or entertainment during daylight hours; and (b) toilet accommodation having a floor area less than 8 m <sup>2</sup>
All purpose groups	(a) Electricity generator rooms (b) Switch room/battery room for emergency lighting system (c) Emergency control room

**Notes –**

- (1) Those areas of the building to which the public are not admitted.
- (2) Those areas of the building to which the public are admitted.

A lift in a basement or enclosed car park shall be approached through a protected lobby or protected corridor unless it is in a protected stairway enclosure.

A lift shall be approached through a protected lobby or protected corridor on a storey which contains a high fire risk area, if the lift also delivers directly into a corridor serving sleeping accommodation.

Lift machine rooms shall be sited over the lift shaft where practicable. Where the lift is within a protected stairway which is the only protected stairway in a building (or part of a building) the machine room shall be located outside the protected stairway, if it cannot be sited over the lift shaft.

**Mechanical ventilation systems**

**1.74** A mechanical ventilation system shall be designed so that in a fire either –

- (a) the air movement in the building is directed away from escape routes; or
- (b) the system is closed down.

Where the system re-circulates air it shall comply with the provisions of BS 5588: Part 9: 1989 in respect of its operation under fire conditions.

Where a pressurization system is installed in a protected stairway all mechanical ventilation and air conditioning systems in the building shall be compatible with it when operating under fire conditions.

**Waste chutes and storage**

**1.75** A room used for the storage of waste or containing a waste chute shall be –

- (a) separated from other parts of the building by fire-resisting construction;
- (b) located outside protected stairways and protected lobbies; and
- (c) accessed from the open air or from a protected lobby which has not less than 0.2 m<sup>2</sup> of permanent ventilation.

## Section 2 – Internal fire spread – Linings

**2.1** This Section contains provisions to restrict the spread of flame over the internal wall and ceiling linings and, in some locations, to limit the contribution they will make to the growth of the fire. This Section must be read in conjunction with Section 6.

**2.2** Provisions regarding linings within concealed spaces, above fire-protecting suspended ceilings and enclosures to sanitary pipework are contained in Section 3. Additional provisions regarding the internal surface of rooflights are contained in Section 4.

**2.3** This Section does not contain provisions regarding the upper surface of floors and stairs.

### Classification of performance of materials

**2.4** The surface spread of flame classification of a lining shall be ascertained by testing in accordance with BS 476: Part 7: 1971 or 1987 (1993). The classifications given in such tests are Classes 1, 2, 3 and 4. Class 0 is achieved where a lining material or the surface of a composite product is either –

**(a)** composed throughout of materials of limited combustibility; or

**(b)** a Class 1 material which has when tested to BS 476: Part 6: 1981 or 1989, a fire propagation index (I) of not more than 12 and a sub-index ( $i_1$ ) of not more than 6.

A composite material of limited combustibility which does not have a surface complying with (a) or (b) shall be classified by test.

Class 0 is the highest classification and Class 4 materials are not acceptable.

**2.5** The term thermoplastic material includes all synthetic polymeric materials which have a softening point lower than 200°C when tested to BS 2782: Part 1: 1976: Method 120A. For the purposes of this Section (and Section 4) thermoplastic materials are classified as TP(a) rigid and TP(a) flexible and TP(b) as follows –

**(a)** To be classified as TP(a) rigid, a thermoplastic material shall be –

(i) rigid solid PVC sheet;

(ii) solid polycarbonate sheet not less than 3 mm thick;

(iii) double or multiple skin rigid sheet of unplasticised PVC or polycarbonate which achieves a classification of Class 1; or

(iv) a rigid product which when tested to BS 2782: Part 5: 1970: Method 508A, extinguishes before the flame reaches the first mark and after removal of the burner, the flaming or afterglow does not exceed 5 seconds.

**(b)** To be classified as TP(a) flexible, a thermoplastic material shall be a flexible product not greater than 1 mm thick which complies with the Type C requirements of BS 5867: Part 2: 1980 (1993) when tested to BS 5438: 1989 Test 2 (excluding the cleansing procedure) with the flame applied to the surface of the specimens for 5, 15, 20 and 30 seconds respectively.

**(c)** To be classified as TP(b) a thermoplastic material shall be –

(i) rigid solid polycarbonate sheet less than 3 mm thick;

(ii) double or multiple skin polycarbonate sheet which does not achieve a classification of Class 1; or

(iii) a product which, when a specimen of material between 1.5 mm and 3 mm thick, tested to BS 2782: Part 5: 1970: Method 508A, has a rate of burning not greater than 50 mm per minute.

**2.6** Where a thermoplastic material is used as a lining to protect a wall or ceiling but is not fully bonded to a non-thermoplastic substrate the surfaces of both the thermoplastic material and the substrate shall meet the provisions of paragraph 2.8. However, where a thermoplastic material is fully bonded to a non-thermoplastic substrate only the surface of the composite need meet the provisions of paragraph 2.8.

## Definition of wall and ceiling

**2.7** For the purposes of the performance of wall and ceiling linings –

- (a)** a wall shall include –
- (i) the surface of glazing (except glazing in a door); and
  - (ii) any part of a ceiling which slopes at an angle of more than 70° to the horizontal;
- (b)** a wall shall not include –
- (i) doors and door frames;
  - (ii) window frames and frames in which glazing is fitted;
  - (iii) architraves, cover moulds, picture rails, skirtings and similar narrow members; and
  - (iv) fire surrounds, mantleshelves and fitted furniture;
- (c)** a ceiling shall include –
- (i) the surface of glazing; and
  - (ii) any part of a wall which slopes at an angle of 70° or less to the horizontal; and
- (d)** a ceiling shall not include –
- (i) trap doors and their frames;
  - (ii) the frames of windows or rooflights and frames in which glazing is fitted; and
  - (iii) architraves, cover moulds, picture rails and similar narrow members.

## Performance of wall and ceiling linings

**2.8** The surface lining of a wall and of a ceiling shall have a classification not lower than the relevant Class given in Table 2.1, subject to the provisions of paragraphs 2.9 to 2.14.

**2.9** In a room any part of the surface of a wall may be of a Class lower than that given in Table 2.1 (but not lower than Class 3) if the total area of those parts in any one room does not exceed either –

- (a)** half the floor area of the room; or
- (b)** (i) in the case of a building of Purpose Group 1 or 2 – 20 m<sup>2</sup>; or  
(ii) in the case of a building of any other purpose group – 60 m<sup>2</sup>,

whichever is the lesser.

**2.10** A suspended ceiling which is to contribute to the fire resistance of a floor/ceiling assembly having a fire resistance of more than 60 minutes shall, in addition to having the classification given in Table 2.1, be constructed of materials of limited combustibility.

**2.11** The ceiling of a room may be constructed, either as a suspended or stretched skin membrane, from panels of a thermoplastic material of the TP(a) flexible classification provided that –

- (a)** each panel is supported on all its sides;
- (b)** each panel is not more than 5 m<sup>2</sup> in area; and
- (c)** it is not a fire-resisting ceiling.

**Table 2.1 Surface classifications for walls and ceilings**

Type of building	Room or circulation space	Class of surface for both walls and ceilings
Purpose Groups 1 and 2	Rooms not exceeding 4 m <sup>2</sup>	3
	All other rooms	1
	Circulation spaces (within a dwelling)	1
	Circulation spaces (common areas)	0
All other purpose groups	Rooms not exceeding 30 m <sup>2</sup>	3
	All other rooms	1
	Circulation spaces	0

---

## Rooflights

**2.12** Other than in a protected stairway a rooflight may be of a classification lower than the relevant Class given in Table 2.1 provided that –

**(a)** where it is –

- (i) a plastic material which has a lower surface with a classification not lower than Class 3; or
- (ii) a thermoplastic material which has a lower surface with a classification not lower than Class 3 or is classified as a TP(a) rigid or TP(b) product,

the size of the rooflight does not exceed the relevant maximum area given in Table 2.2; and

**(b)** where there is more than one rooflight in the ceiling of a room or space –

- (i) the area of rooflights does not exceed the relevant maximum total area given in Table 2.2; and
- (ii) the disposition of the rooflights complies with the limitations given in Diagram 2.1.

The upper surface of a rooflight is subject to the provisions of Section 4.

## Windows

**2.13** A window in the external wall of a circulation space and all internal glazed areas shall be glazed with a material having a classification not lower than that given in Table 2.1.

A window in an external wall of a room may be glazed with a thermoplastic material classified as a TP(a) rigid product.

## Lighting diffusers

**2.14** This paragraph applies to a lighting diffuser which forms part of a ceiling. It does not apply to the diffuser of a light fitting which is attached to the soffit of, or suspended beneath, a ceiling.

Lighting diffusers may be translucent or open-structured elements and may be part of a light fitting or be used below a rooflight or other source of light.

A thermoplastic lighting diffuser shall not be incorporated in a fire-protecting or fire-resisting ceiling unless it has been satisfactorily tested as part of a luminaire within a ceiling assembly that provides the appropriate fire resistance. A ceiling in a room or in a circulation space (other than a protected stairway) may incorporate a thermoplastic lighting diffuser provided that –

**(a)** the wall and ceiling surfaces exposed within the space above the ceiling (other than the upper surface of the lighting diffuser) comply with the classification given in Table 2.1 for the space below the ceiling; and

**(b)** the lighting diffuser is either –

- (i) classified as a TP(a) rigid product; or
- (ii) classified as a TP(b) product and is loosely mounted so that it will fall out of its mounting on initial heating. Where more than one such lighting diffuser is fitted, they shall be limited in their extent in accordance with Table 2.2. Small lighting diffusers may be grouped together (see Note (1) to Table 2.2 and Diagram 2.1).

**Table 2.2 Limitations on Class 3 plastic rooflights and thermoplastic rooflights and lighting diffusers in suspended ceilings**

Minimum classification of lower surface	Use of space below rooflight or diffuser	Maximum area of each rooflight or diffuser panel <sup>(1)</sup> (m <sup>2</sup> )	Maximum total area of rooflights or diffuser panels as a percentage of floor area of the space in which the ceiling is located (%)	Minimum separation distance between rooflights or diffuser panels <sup>(1)</sup> (m)
TP(a)	Rooms or circulation spaces (except protected stairways)	No limit <sup>(2)</sup>	No limit	No limit
Class 3 <sup>(3)</sup> or TP(b)	Rooms	5	50	3
	Circulation spaces (except protected stairways)	5	15	3

**Notes –**



- (1) Small rooflights or diffuser panels may be grouped together provided that the overall size of the group and the space between one group and any others comply with the limitations given in Diagram 2.1.
- (2) Lighting diffusers of a TP(a) flexible material are limited to panels of not more than 5 m<sup>2</sup> (see paragraph 2.11).
- (3) There are no limitations on Class 3 materials in certain small rooms (see Table 2.1).

**Diagram 2.1 Limitations on groups of class 3 plastic rooflights and TP(b) thermoplastic rooflights and lighting diffusers in suspended ceilings**

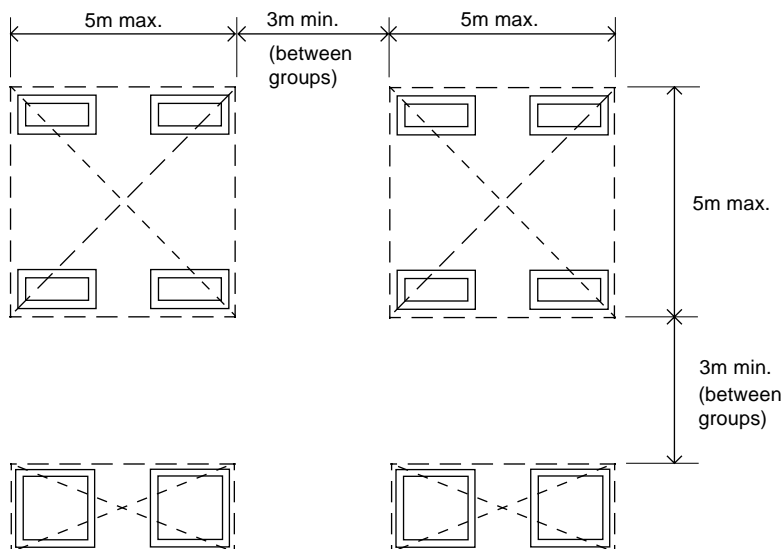
see para 2.12(b), 2.14(b) and Table 2.2 note(1)



**Key**

-  rooflight or lighting diffuser
-  separate group of rooflights or lighting diffusers

## Section 3 – Internal fire spread – Structure

**3.1** The spread of fire within a building can be restricted by –

- (a) ensuring the elements of structure and certain other components of the building have a minimum standard of fire resistance;
- (b) subdividing the building into compartments with fire-resisting construction;
- (c) subdividing concealed and extensive cavities within the construction; and
- (d) protecting openings in, and penetrations through, fire-resisting construction.

Where a building is divided into separated parts by a compartment wall (or walls), running the full height of the building in a continuous vertical plane, the provisions of this Section may be applied separately to each separated part.

### Tests for fire resistance

**3.2** The fire resistance of an element of structure or other component of a building is a measure of its ability to withstand the effects of fire in one or more of the following ways –

- (a) resistance to collapse (loadbearing capacity);
- (b) resistance to fire penetration (integrity); and
- (c) resistance to transfer of excessive heat (insulation).

Tests for fire resistance shall be in accordance with, in the case of –

- (i) loadbearing elements – BS 476: Parts 20 and 21: 1987;
- (ii) non-loadbearing elements – BS 476: Parts 20 and 22: 1987;
- (iii) suspended ceilings – BS 476: Parts 20 and 23: 1987;
- (iv) ventilation ducts – BS 476: Parts 20 and 24: 1987; and
- (v) any element of construction tested prior to 1 January 1988 – BS 476: Part 8: 1972.

A provision for an element of structure or other component of the building to have a specific period of fire resistance means that it shall have not less than that period, in respect of the relevant aspects of performance given in Table 3.1.

### Fire resistance of elements of structure and certain other components of the building

**3.3** An element of structure and those other components of the building given in Table 3.1 shall have a minimum period of fire resistance of not less than that given in Tables 3.1 and 3.2 for the purpose group of the building.

Where one element of structure or other component supports, carries or gives stability to another, the fire resistance of the supporting element or component shall be not less than the minimum period of fire resistance for the other element (whether that other element is loadbearing or not).

Where an element or structure or other component forms part of more than one building or compartment, the fire resistance of that element or component shall be not less than the greater of the relevant provisions.

**Table 3.1 Specific provisions of test for fire resistance of elements of structure and other components of a building**

Part of building	Minimum provisions when tested to the relevant part of BS 476 (minutes)			Method of exposure
	Loadbearing capacity <sup>(1)</sup>	Integrity	Insulation	
1 Structural frame, beam or column	See Table 3.2	Not applicable	Not applicable	Exposed faces
2 Loadbearing wall (which is not also a wall described in any of the following items)	See Table 3.2	Not applicable	Not applicable	Each side separately
3 Floors –				
(a) in upper storey of two storey dwellinghouse (but not over a garage)	30 <sup>(2)</sup>	15 <sup>(2)</sup>	15 <sup>(2)</sup>	From underside
(b) any other floor	See Table 3.2	See Table 3.2	See Table 3.2	
4 Roofs –				
(a) any part forming an escape route	30	30	30	From underside
(b) any roof that performs the function of a floor	See Table 3.2	See Table 3.2	See Table 3.2	
5 External walls –				
(a) any part less than 1 m from any point on the relevant boundary	See Table 3.2	See Table 3.2	See Table 3.2	Each side separately
(b) any part 1 m or more from the relevant boundary	See Table 3.2	See Table 3.2	15 <sup>(3)</sup>	From inside
6 Compartment wall separating occupancies	60 or see Table 3.2 (whichever is less)	60 or see Table 3.2 (whichever is less)	60 or see Table 3.2 (whichever is less)	Each side separately
7 Compartment wall other than in item 6 above	See Table 3.2	See Table 3.2	See Table 3.2	Each side separately

**Table 3.1 Specific provisions of test for fire resistance of elements of structure and other components of a building**

Part of building	Minimum provisions when tested to the relevant part of BS 476 (minutes)			Method of exposure
	Loadbearing capacity <sup>(1)</sup>	Integrity	Insulation	
8 Protected shafts, excluding any firefighting shafts –				
(a) any glazing described in paragraph 3.19	Not applicable	30	No provision <sup>(4)</sup>	Each side separately
(b) any other part between the shaft and a protected lobby or protected corridor described in paragraph 3.19	30	30	30	
(c) any part not described in (a) or (b) above	See Table 3.2	See Table 3.2	See Table 3.2	
9 Enclosure (which does not form part of a compartment wall or a protected shaft) to a –				
(a) protected stairway	30	30	30 <sup>(5)</sup>	Each side separately
(b) lift shaft	30	30	30	
(c) service shaft	30	30	30	
10 Firefighting shafts –				
(a) construction separating firefighting shafts from remainder of building	120	120	120	From side remote from shaft
	60	60	60	From shaft side
(b) construction within a firefighting shaft separating firefighting stairway, firefighting lift shaft and firefighting lobby	60	60	60	Each side separately

**Table 3.1 Specific provisions of test for fire resistance of elements of structure and other components of a building**

Part of building	Minimum provisions when tested to the relevant part of BS 476 (minutes)			Method of exposure
	Loadbearing capacity <sup>(1)</sup>	Integrity	Insulation	
11 Enclosure (which is not a compartment wall or described in item 8) to a –				Each side separately
(a) protected lobby	30	30	30 <sup>(5)</sup>	
(b) protected corridor	30	30	30 <sup>(5)</sup>	
12 Subdivision of a corridor	30	30	30 <sup>(5)</sup>	Each side separately
13 Wall separating an attached or integral garage from a dwellinghouse	30	30	30	From garage side
14 Fire-resisting construction in dwellings not described elsewhere	30	30	30 <sup>(5)</sup>	Each side separately
15 Cavity barrier	Not applicable	30	15	Each side separately
16 Ceiling shown in Diagram 3.6 or 3.7	Not applicable	30	30	From underside
17 Fire-resisting duct referred to in paragraph 3.33(e)	Not applicable	30	No provision	From outside
18 Casing around a drainage system as shown in Diagram 3.11	Not applicable	30	No provision	From outside
19 Flue walls described in paragraph 3.36	Not applicable	See Table 3.2	See Table 3.2	From outside
20 Fire doors	See Table 3.5			

**Notes –**

- (1) Applies to loadbearing elements only.
- (2) This standard of fire resistance is referred to as modified 30 minutes.
- (3) 30 minutes for any part adjacent to an external escape route (but no provision for glazed elements in respect of insulation).
- (4) Except for any limitations on glazed elements given in Table 1.8.
- (5) See Table 1.8 for permitted extent of uninsulated glazed elements.

**Table 3.2 Minimum periods of fire resistance**

Purpose group of building	Minimum period (minutes) for elements of structure and other components of the building forming part of					
	Basement storey <sup>+</sup> including floor over		Ground or upper storey			
	Depth (m) of basement		Height (m) of top floor above ground in building or separated part of building <sup>(1)</sup>			
	More than 10	Not more than 10	Not more than 5	More than 5 not more than 20	More than 20 not more than 30	More than 30
1 Residential (dwellings) – (a) flats and maisonettes (b) and (c) dwellinghouses	90	60	30*	60 <sup>(2)**</sup>	90**	120**
	Not relevant	30*	30*	60 <sup>@</sup>	Not relevant	Not relevant
2 Residential – (a) institutional (b) other residential	90	60	30* <sup>##</sup>	60	90	120 <sup>#</sup>
	90	60	30*	60	90	120 <sup>#</sup>
3 Office – not sprinklered sprinklered <sup>(3)</sup>	90	60	30*	60	90	Not permitted
	60	60	30*	30*	60	120 <sup>#</sup>
4 Shop and commercial – not sprinklered sprinklered <sup>(3)</sup>	90	60	60	60	90	Not permitted
	60	60	30*	60	60	120 <sup>#</sup>
5 Assembly and recreation – not sprinklered sprinklered <sup>(3)</sup>	90	60	60	60	90	Not permitted
	60	60	30*	60	60	120 <sup>#</sup>
6 Industrial – not sprinklered sprinklered <sup>(3)</sup>	120	90	60	90	120	Not permitted
	90	60	30*	60	90	120 <sup>#</sup>

**Table 3.2 Minimum periods of fire resistance**

Purpose group of building	Minimum period (minutes) for elements of structure and other components of the building forming part of					
	Basement storey* including floor over		Ground or upper storey			
	Depth (m) of basement		Height (m) of top floor above ground in building or separated part of building <sup>(1)</sup>			
	More than 10	Not more than 10	Not more than 5	More than 5 not more than 20	More than 20 not more than 30	More than 30
7 Storage and other non-residential						
(a) any building or part not described elsewhere –						
not sprinklered	120	90	60	90	120	Not permitted
sprinklered <sup>(3)</sup>	90	60	30*	60	90	120 <sup>#</sup>
(b) car park for light vehicles –						
(i) open sided car park <sup>(4)</sup>	Not applicable	Not applicable	15* <sup>\$</sup>	15* <sup>\$</sup>	15* <sup>\$</sup>	Not applicable
(ii) any other car park	90	60	30*	60	90	120 <sup>#</sup>

**Notes –**

- + The floor over a basement (or if there is more than one basement, the floor over the topmost basement) shall meet the provisions for the ground and upper storeys if that period is higher.
- \* Increased to a minimum of 60 minutes for compartment walls separating buildings.
- \*\* Reduced to 30 minutes for any floor within a maisonette, but not if the floor contributes to the support of the building as a whole.
- @ Reduced to 30 minutes for a dwellinghouse having not more than three storeys and for the wall or floor separating a dwellinghouse from an attached or integral garage.
- ## Multi-storey hospitals designed in accordance with NHS Firecode documents shall have a minimum of 60 minutes.
- \$ Increased to a minimum of 30 minutes for elements protecting the means of escape.
- # Reduced to 90 minutes for elements not forming part of the structural frame.
- (1) A single storey building or a single storey separated part of a building shall be subject to the period given under the heading “not more than 5” and where it has a basement storey or storeys they shall be subject to the period appropriate to their depth.
- (2) Reduced to 30 minutes where an existing building of not more than three storeys is being converted.
- (3) “Sprinklered” means that the building is fitted throughout with an automatic sprinkler system complying with the relevant requirements of BS 5306: Part 2: 1990 in respect of occupancy rating and additional requirements for life safety.
- (4) Car parks which comply with paragraphs 3.40 and 3.41.

### Fire protecting suspended ceilings

**3.4** A suspended ceiling will only be accepted as contributing to the fire resistance of a floor where that ceiling is of the appropriate type given in Table 3.3.

### Fire-resisting construction

**3.5** Where an element of structure or other component of the building is required to have fire resistance it may be constructed in accordance with an appropriate specification in Part II of the Building Research Establishment Report – Guidelines for the construction of fire-resisting structural elements (BR 128: 1988).

### Variations of the provisions regarding fire resistance

**3.6** A provision for an element of structure to have fire resistance shall not apply to –

(a) any part of the structure which only supports a roof unless –

(i) the roof performs the function of a floor, e.g. as a means of escape, for parking of vehicles, etc.;

(ii) the structure is part of, or is essential for the stability of an external wall which, under the provisions Section 4, cannot be an unprotected area; or

(iii) the structure is part of or supports a compartment wall or a wall between a dwellinghouse and an attached or integral garage;

(b) in the case of a single storey building or a building which consists of a ground storey and one or more basement storeys – any element of structure which forms part of the ground storey unless the element –

(i) supports a gallery; or

(ii) is located as defined in sub-paragraph (a)(ii) or (iii);

(c) the lowest floor of a building; and

(d) a platform floor.

**Table 3.3 Limitations of fire-protecting suspended ceilings**

Height of building or separated part (m)	Type of floor	Fire resistance of floor required by Table 3.2 (minutes)	Type of suspended ceiling (see notes)
Less than 20	Not compartment	60 or less	A, B, C or D
	Compartment	Less than 60	
			60
20 or more	Any	60 or less	C or D
No limit	Any	More than 60	D

**Notes –**

#### Ceiling type

#### Description

- A Surface of ceiling exposed to the cavity shall be Class 0 or Class 1.
- B Surface of ceiling exposed to the cavity shall be Class 0.
- C Surface of ceiling exposed to the cavity shall be Class 0. Ceiling shall not contain easily openable access panels.
- D Ceiling shall be of a material of limited combustibility and not contain easily openable access panels. Any insulation above the ceiling shall be of a material of limited combustibility.

Any access panels provided in fire-protecting suspended ceilings of Type C or D shall be secured in position by releasing devices or screw fixings, and they shall be shown to have been tested in the ceiling assembly in which they are incorporated.

---

**3.7** Where one side of a basement storey or compartment is (due to the slope of the ground) open at and provides means of escape and fire brigade access at ground level and smoke venting, the period of resistance for the elements of structure and other components of the building in that basement storey or compartment shall be that appropriate to a storey above the ground.

**3.8** Where the roof space of an existing two storey dwellinghouse is to be converted to form a new storey the provisions of this Section are for the floors, both old and new, to have full 30 minutes fire resistance. However, the existing first floor construction need not be upgraded where it separates rooms provided –

- (a)** only one storey is being added;
- (b)** the new storey contains not more than two habitable rooms;
- (c)** the total area of the new storey is not more than 50 m<sup>2</sup>; and
- (d)** it has at least modified 30 minutes fire resistance.

### **Raised storage floors**

**3.9** Raised free-standing floors supported by racking are frequently erected for storage purposes and whether they are considered as a gallery or as a floor forming a storey the provisions for fire resistance for elements of structure apply.

In the case of automated storage systems where people do not normally frequent any of the raised storage tiers it is not necessary to provide the storage structure with fire resistance.

Where people frequent the storage tiers in the course of their normal use the provisions for fire resistance for the raised storage floor and its supporting structure may be dispensed with where the number of persons likely to be on the raised floor at any one time is low (and does not include members of the public) and the raised floor –

- (a)** is within a single storey building or compartment and is structurally free-standing;
- (b)** consists of only one tier with the space both above and below used only for storage purposes;
- (c)** is served by a stair or stairs to comply with the relevant maximum travel distance given in Table 1.2 and at least one stair discharges within 4.5 m of an exit from the building or compartment;

**(d)** has a surface classification on the underside not lower than Class 3 (see paragraph 2.4); and

**(e)** is designed and constructed so that any persons on the floor will be readily aware of a fire starting on the lower level. Design and construction features include the use of perforations in the floor, leaving a space between the floor and the walls of the space housing it and automatic fire detection and alarm systems. However, where the length or width of a raised storage floor is greater than 10 m an automatic fire detection and alarm system shall be provided to give warning of a fire below the floor.

### **Compartmentation**

**3.10** The degree to which a building or separated part of a building is subdivided into compartments is related to the use of and the fire load in the building, the height to the top storey and the provision or otherwise of a sprinkler system. Compartmentation may assist in meeting the provisions of Section 1 or Section 4 of this Technical Booklet.

For compartmentation to be effective there shall be continuity at the junctions of the fire-resisting elements enclosing the compartment and any opening from one compartment to another shall not present a weakness. The spaces which connect compartments, e.g. stairs, service shafts, etc. shall be enclosed to form protected shafts and their walls and floors shall be constructed as compartment walls and compartment floors.

### **Provision of compartment walls and compartment floors**

**3.11** In buildings of all purpose groups –

- (a)** a compartment wall shall be constructed where a wall –
  - (i) is common to two or more buildings; or
  - (ii) is provided to divide a building into separated parts; and
- (b)** a compartment wall or a compartment floor, as appropriate shall be constructed –
  - (i) to separate parts of a building which are in different purpose groups (see paragraph 6.2); and
  - (ii) where a wall or floor is provided to divide a building into different occupancies (i.e. ownership, tenancies or similar).

**3.12** The following walls or floors shall be constructed as compartment walls or compartment floors –

**(a)** In a building of Purpose Group 1(b) or (c) –

- (i) a wall which separates semi-detached dwellinghouses or dwellinghouses in a terrace (in these cases each dwellinghouse shall be treated as a separate building); and
- (ii) a wall or floor which separates a dwellinghouse from an attached or integral garage;

**(b)** in a building of Purpose Group 1(a) –

- (i) every floor, other than a floor within a maisonette;
- (ii) every wall which separates a flat or maisonette from any other part of the building; and
- (iii) every wall enclosing a communal waste container ;

**(c)** in a building of Purpose Group 2 –

- (i) every floor; and
- (ii) in the case of a health care building –

a wall needed to divide a storey into compartments for means of escape purposes [see regulation E3(c) and (d)]; and

**(d)** in a building of Purpose Group 3, 4, 5, 6, or 7 –

- (i) a wall which is needed to subdivide a building, or separated part of a building, so that the maximum floor area or maximum volume, as appropriate, of a compartment given in Table 3.4 is not exceeded;
- (ii) every floor in a building or a separated part of a building (other than the lowest floor) where that building or separated part has a floor at a height of more than 30 m above ground level;
- (iii) the floor of the ground storey where a building or separated part of a building has one or more basements; and
- (iv) every basement floor in a building, or a separated part of a building (other than the lowest basement floor), where that building or separated part has a floor at a depth of more than 10 m below ground level.

**Table 3.4 Maximum floor areas and volumes of buildings or compartments having more than one storey**

Purpose group of building (or part)	Height of top storey of building above ground level (m)	Floor area of any one storey in the building or compartment (m <sup>2</sup> )	Maximum compartment volume (m <sup>3</sup> )
3	No limit	No limit	No limit
4 and 5	Not sprinklered	2000	No limit
	Sprinklered <sup>(1)</sup>	4000	No limit
6 <sup>(3)</sup>	Not sprinklered	7000 2000 <sup>(2)</sup>	No limit No limit
	Sprinklered <sup>(1)</sup>	14000 4000 <sup>(2)</sup>	No limit No limit
7(a) <sup>(3)</sup>	Not sprinklered	No limit No limit	20000 4000 <sup>(2)</sup>
	Sprinklered <sup>(1)</sup>	No limit No limit	40000 8000 <sup>(2)</sup>
7(b)	No limit	No limit	No limit

**Notes –**

- (1) “Sprinklered” means that the building is fitted throughout with an automatic sprinkler system meeting the relevant recommendations of BS 5306: Part 2: 1990, i.e. the relevant occupancy rating together with the additional requirements for life safety.
- (2) This reduced limit applies only to those storeys which are more than 20 m above ground level.
- (3) There may be additional limitations on floor area, volume and/or sprinkler provisions in certain industrial and storage uses under other legislation.

## Construction of compartment walls and compartment floors

**3.13** Every compartment wall and compartment floor shall –

(a) form a complete barrier to fire between the compartments they separate; and

(b) have the appropriate fire resistance required by paragraph 3.3.

A compartment wall between two or more buildings shall extend the full height of the buildings in a continuous vertical plane. Thus adjoining buildings shall be separated only by walls and not by floors.

A compartment wall used to form a separated part of a building shall extend the full height of the building in a continuous vertical plane. Thus separated parts shall be separated only by walls and not by floors.

## Junctions of compartment walls and compartment floors with other walls

**3.14** Where a compartment wall or compartment floor meets a compartment wall or an external wall the junction shall maintain the fire resistance for a period of not less than the period of fire resistance required by the compartment wall or compartment floor.

## Junction of compartment walls and roofs

**3.15** Where a compartment wall meets a roof it shall either –

(a) be extended up through the roof to a height of not less than 375 mm above the top surface of the roof covering; or

(b) where the roof covering has a designation of AA, AB or AC (see paragraph 4.18), on a substrate or deck of a material of limited combustibility, for a width of not less than 1.5 m on either side of the junction [see Diagram 3.1(a)] – be taken up to meet the underside of the roof covering or deck and the junction fire stopped. However, where the building is of Purpose Group 1, 2(b), 3 or 5 and is not more than 15 m in height a combustible substrate of timber boarding, wood wool slabs or timber tiling battens may be carried over the compartment wall provided it is fully bedded in mortar, or no less suitable material, over the entire width of the wall [see Diagram 3.1(b)].

**Diagram 3.1 Junction of compartment wall and roof**

see para 3.15(b)

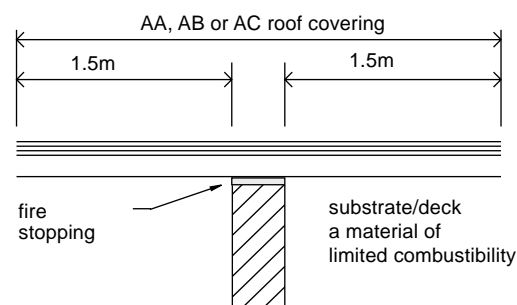

**(a) Any building**

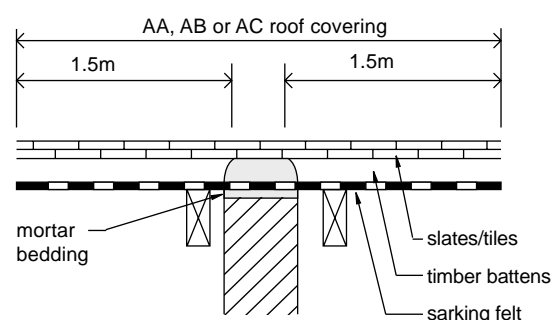

**(b) Building of Purpose Group 1, 2(b), 3 or 5 not more than 15m in height**

## Openings in compartment walls which separate buildings or occupancies

**3.16** A compartment wall which is common to two or more buildings, or which separates different occupancies in the same building, shall have no openings other than those for –

(a) means of escape in case of fire – when a fire resisting self-closing door (see paragraphs 3.22 to 3.26 having the same period of fire resistance as that of the compartment wall shall be provided; and

(b) the passage of a pipe – when the opening in the wall shall comply with paragraphs 3.34 and 3.37 to 3.39.

## Openings in other compartment walls and in compartment floors

**3.17** A compartment wall (other than one described in paragraph 3.16) and a compartment floor shall have no openings other than those –

**(a)** having a fire resisting self-closing door (see paragraph 3.22 to 3.26) and in the case of a doorway between a dwellinghouse and an attached or integral garage, having a threshold height of not less than 100 mm (see Diagram 3.2);

**(b)** for the passage of pipes, ventilation ducts, chimneys, appliance ventilation duct or duct encasing one or more flue pipes – when the opening in the compartment wall or compartment floor shall comply with paragraphs 3.34 to 3.39;

**(c)** for a waste chute system constructed of non-combustible materials; and

**(d)** for a protected shaft which complies with the provisions of paragraph 3.18 to 3.21.

## Protected shafts between compartments

**3.18** A protected shaft shall only be used to accommodate stairs, lifts, escalators, chutes, ducts, pipes, sanitary accommodation and washrooms. Where a protected shaft contains a protected stairway Section 1 imposes additional requirements (see paragraphs 1.51 to 1.55) and where it contains a firefighting stairway Section 5 imposes additional requirements (see paragraphs 5.2 to 5.5).

The construction enclosing a protected shaft, other than a wall which is part of an external wall, shall –

**(a)** form a complete barrier to fire between the different compartments which the shaft connects;

**(b)** have the same fire resistance as the compartment through which it is passing, other than where a glazed screen complying with paragraph 3.19 is provided; and

**(c)** satisfy the provisions regarding ventilation in paragraph 3.20 and regarding the treatment of openings in paragraph 3.21.

**Diagram 3.2 Doorway between dwellinghouse and garage**

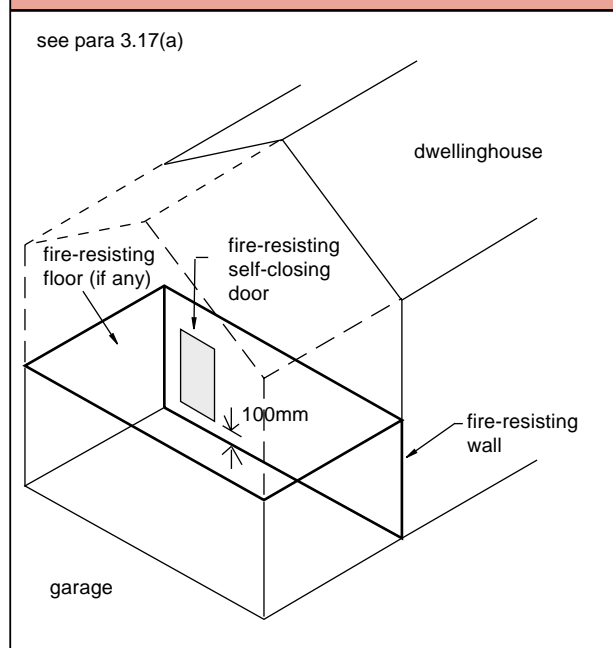

## Glazed screens in protected shafts

**3.19** Glazing may be incorporated in the wall between a protected shaft containing a stairway, and a corridor or lobby which gives access to that stairway provided that –

**(a)** the protected shaft is not a firefighting shaft;

**(b)** the protected shaft is not required to have more than 60 minutes fire resistance; and

**(c)** the glazing has not less than 30 minutes fire resistance in respect of integrity; and either –

(i) the glazing is limited in extent in accordance with Table 1.8; or

(ii) the corridor or lobby has not less than 30 minutes fire resistance (see Diagram 3.3).

## Pipes for oil or gas and ventilation ducts in protected shafts

**3.20** Where a protected shaft contains –

**(a)** a stairway and/or a lift it shall not contain –

- (i) a pipe conveying oil, other than in the mechanism of a hydraulic lift; or
- (ii) a ventilation duct, other than a duct provided for the purposes of pressurizing the shaft to keep it free from smoke in the event of fire; and

**(b)** a pipe conveying flammable gas it shall be adequately ventilated directly to external air by ventilation openings at both high and low levels in the shaft. Any pipe conveying natural gas or LPG shall be of screwed steel or of all welded steel construction.

## Openings in protected shafts

**3.21 (a)** Where the wall of a protected shaft is common to two or more buildings no opening shall be provided in that wall other than for –

- (i) means of escape in case of fire – when a fire-resisting self-closing door, having the same period of fire resistance as the protected shaft, shall be provided; and
- (ii) the passage of a pipe – when the opening shall comply with paragraphs 3.34 and 3.37 to 3.39.

**(b)** Other than in walls subject to sub-paragraph (a) and external walls, a protected shaft shall only have openings for –

- (i) a fire-resisting self-closing door which complies with paragraph 3.22;
- (ii) the passage of a pipe where the opening complies with paragraphs 3.34 and 3.37 to 3.39;
- (iii) where the shaft is or contains a ventilation duct – the inlets to, outlets from and opening for a ventilation duct which complies with paragraph 3.35;
- (iv) where the shaft is pressurized for the purposes of paragraph 1.47 – the inlet from and opening for the ductwork; and
- (v) where the shaft contains a lift – the passage of lift cables into a lift motor room. Where the motor room is at the bottom of the shaft the opening shall be as small as practicable

**Diagram 3.3 Glazed screen separating protected shaft from corridor or lobby**

see para 3.19(c)

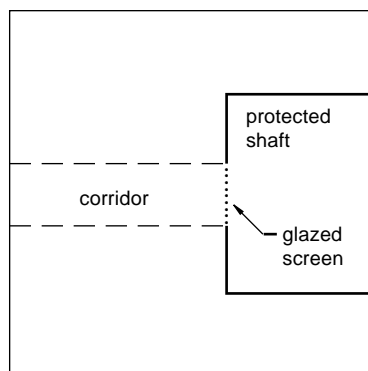

**(a) With corridor**

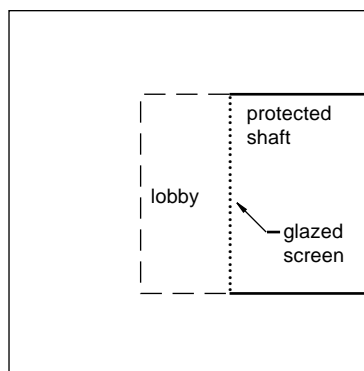

**(b) With lobby**

### Key

- fire resistance provision for protecting structure or not more than 60 minutes
- - - fire resistance of construction to be at least 30 minutes (including doors)
- ..... fire resistance of glazing to be at least 30 minutes (including doors)

---

## Fire doors

**3.22** A fire door shall have the performance appropriate to the location given in Table 3.5 and shall be fitted with an automatic self-closing device (other than those fire doors to cupboards and ducts, which are to be kept locked shut when not in use).

Fire doors are classified by their performance under test to BS 476: Part 22 in respect of integrity expressed in minutes. A suffix (S) is added for doors where smoke leakage at ambient temperatures is to be restricted. The method of test exposure is from each side of the door separately, except in the case of lift doors, which are tested from the landing side only.

**3.23** A fire door shall only be held open by –

**(a)** a fusible link, provided that the provisions of paragraph 3.25 are complied with where the door opening is provided for means of escape;

**(b)** an automatic release mechanism provided that the door can also be closed manually and does not give access to –

(i) the only escape stairway serving a building or part of a building;

(ii) an escape stairway serving a building or compartment of Purpose Group 1 or 2; or

(iii) a firefighting stairway; or

**(c)** a door co-ordinator device which co-ordinates the closing sequence of rebated double leaf swing doors.

**3.24** Unless shown to be satisfactory when tested as part of a fire door assembly, the hinges on which a fire door is hung shall be made from material having a melting point of at least 800°C

**3.25** Where an opening is provided for, or opens onto, a means of escape and it is intended that the door shall be held open by a fusible link, a second door having 30 minutes fire resistance shall be provided. This second door shall be capable of closing the opening and be easily opened by hand.

Where two fire doors are fitted in the same opening and each door is capable of closing that opening, the total fire resistance may be taken as the sum of their individual fire resistance.

**3.26** All fire doors, other than those listed below, shall be marked with an appropriate fire safety sign complying with BS 5499: Part 1: 1990 indicating whether the door is –

**(a)** to be kept closed when not in use;

**(b)** to be kept locked shut when not in use; or

**(c)** held open by an automatic release mechanism.

Signs shall be provided on both sides of the door except for doors to cupboards and service ducts which shall be marked on the outside only.

The following fire doors do not require to be marked –

**(i)** doors within dwellinghouses;

**(ii)** doors to and within flats and maisonettes;

**(iii)** bedroom doors in Purpose Group 2 buildings; and

**(iv)** lift entrance doors.

**Table 3.5 Fire doors**

Location of door	Minimum fire resistance of door in terms of integrity (minutes) <sup>(1)</sup>
1 In a compartment wall separating buildings	As for the wall in which the door is fitted, but a minimum of 60
2 In a compartment wall not described in item 1 above – (a) where it separates a flat or maisonette from a space in common use (b) where it forms part of a protected shaft forming a stairway situated wholly or partly above the adjoining ground in a building of Purpose Group 1(a), 2, 3 or 5 (c) enclosing a protected shaft forming a stairway not described in (b) above (d) not described in (a), (b) or (c) above	30S <sup>(2)</sup>  30S <sup>(2)</sup>  Half the period of fire resistance of the wall in which it is fitted but 30 minimum and with suffix S As for the wall it is fitted in, but with suffix S if the door is used for progressive horizontal evacuation
3 In a compartment floor	As for the floor in which it is fitted
4 In the wall of a protected shaft, not described in items 2(b) or (c) above, which is – (a) a protected stairway (other than one described in item 9 below) (b) a lift shaft or a service shaft (c) any other shaft	30S <sup>(2)</sup>  30 30S <sup>(2)</sup>
5 In the enclosure of – (a) a protected lobby or protected corridor to a stairway (b) any other protected corridor	30S <sup>(2)</sup>  20S <sup>(2)</sup>
6 In an external wall and giving access to an external escape route	30
7 Subdividing – (a) corridors connecting alternative storey exits (b) dead-end portions of corridors from the remainder of the corridor	20S <sup>(2)</sup> 20S <sup>(2)</sup>
8 Any door – (a) within a cavity barrier (b) between a dwellinghouse and a garage (c) in the enclosure to a communal area in sheltered housing	30 30 30S <sup>(2)</sup>
9 Any door – (a) forming part of the enclosures to a protected stair in a single family dwellinghouse (b) within any other fire-resisting construction in a dwelling	20 20

## Notes –

(1) To BS 476: Part 22 (or BS 476: Part 8 subject to paragraph 3.2).

(2) Unless pressurization techniques complying with BS 5588: Part 4 are used, these doors should also have a leakage rate not exceeding 3 m<sup>3</sup>m/hour (head and jambs only) when tested at 25 Pa under BS 476: Section 31.1.

## Provision of cavity barriers

**3.27** To restrict the spread of smoke and flame through concealed spaces in the construction of a building cavity barriers shall be provided –

(a) in a building of any purpose group –

(i) at the intersection of fire-resisting construction and an element containing a cavity as shown in Diagram 3.4; and

(ii) as set out in Table 3.6 for the appropriate purpose group of the building and the specified locations.

[Note – alternative arrangements for items 1, 3 and 4 are shown in Diagram 3.5 and for item 2 in Diagram 3.6. Notes (3) and (4) to Table 3.6 are supported by Diagrams 3.7 and 3.8 respectively]; and

(b) in a building of Purpose Group 2, 3, 4, 5, 6 or 7 – so that the maximum dimension of a cavity, (other than one described in paragraph 3.31 or 3.32) shall be not greater than that given in Table 3.7 for the appropriate location of the cavity.

**3.28** A cavity barrier shall not be used above a compartment wall to complete the line of compartmentation, i.e. a compartment wall shall be carried up to a compartment floor or to a roof.

**Table 3.6 Provision of cavity barriers**

Item	Cavity barriers to be provided	Purpose group to which the provision applies			
		1a	1b & c	2	3, 4, 5, 6 and 7
1	At the top of an external cavity wall and at the junction between an external cavity wall and a compartment wall that separates buildings, except where the external cavity complies with Diagram 3.5	✓	✓	✓	✓
2	Above <sup>(1)</sup> the enclosures to a protected stairway in a dwellinghouse of three or more storeys (see Diagram 3.6) <sup>(3)</sup>	N/A	✓	N/A	N/A
3	At the junction between an external cavity wall and every compartment floor and compartment wall, except where the external cavity wall complies with Diagram 3.5	✓	N/A	✓	✓
4	At the junction between a cavity wall and every compartment floor, compartment wall, or other wall or door assembly which forms a fire-resisting barrier, except where the external cavity wall complies with Diagram 3.5	✓	N/A	✓	✓
5	In a protected escape route, above <sup>(1)</sup> any fire resisting construction which is not carried full storey height <sup>(2)</sup> , or (in the case of a top storey) to the underside of the roof covering <sup>(3)</sup>	✓	N/A	✓	✓

**Table 3.6 Provision of cavity barriers**

Item	Cavity barriers to be provided	Purpose group to which the provision applies			
		1a	1b & c	2	3, 4, 5, 6 and 7
6	Above <sup>(1)</sup> any bedroom partitions which are not carried full storey height <sup>(2)</sup> , or (in the case of a top storey) to the underside of the roof covering <sup>(3)</sup>	N/A	N/A	✓	N/A
7	Above <sup>(1)</sup> any corridor enclosures which are not carried full storey height <sup>(2)</sup> , or (in the case of a top storey) to the underside of the roof covering, where the corridor (which is not a protected corridor) is subdivided to prevent fire or smoke affecting two alternative escape routes simultaneously (see Section 1) <sup>(4)</sup>	N/A	N/A	✓	✓
8	To subdivide any cavity (including any roof space ) so that the distance between cavity barriers does not exceed the dimensions given in Table 3.7	N/A	N/A	✓	✓
9	Within the void behind the external face of rainscreen cladding at every floor level, and on the line of compartment walls abutting the external wall, of buildings which have a floor more than 20 m above ground level	✓	N/A	✓	N/A

**Notes –**

✓ Provision applies.

N/A Not applicable.

(1) Above and in the same plane as the element.

(2) Full storey height means to the underside of the structural floor above.

(3) The cavity barriers in items 2, 5 and 6 are not required where the cavity is enclosed on the lower side by a fire-resisting ceiling (as shown in Diagram 3.7) which extends throughout the building, compartment or separated part.

(4) The cavity barrier in item 7 is not required where the storey is subdivided by fire-resisting construction carried full storey height<sup>(2)</sup> and passing through the line of subdivision of the corridor (see Diagram 3.8), or where the cavity is enclosed on the lower side as described in Note (3) above.**Table 3.7 Maximum dimension of a cavity in Purpose Group 2, 3, 4, 5, 6 and 7 buildings**

Location of cavity	Class of surface exposed in cavity (excluding surface of any pipe, cable or conduit, or insulation to any pipe)	Maximum dimension of a cavity in any direction (m)
Between a roof and a ceiling	Any	20
Any other cavity	Class 0 or Class 1	20
	A class other than Class 0 or Class 1	10

**Notes –**

Exceptions to these provisions are given in paragraphs 3.31 and 3.32.

## Construction of cavity barriers

**3.29** A cavity barrier shall be constructed to provide fire resistance of not less than 30 minutes in respect of integrity and 15 minutes in respect of insulation (see item 15 of Table 3.1), however, a cavity barrier in a stud partition or wall may be formed of –

- (a) steel at least 0.5 mm thick;
- (b) timber at least 38 mm thick;
- (c) polyethylene sleeved mineral wool or mineral wool slab, in either case under compression when installed in the cavity; or
- (d) calcium silicate, cement based or gypsum based boards at least 12.5 mm thick.

A cavity barrier may be formed by any construction provided for another purpose if that construction meets the provisions for a cavity barrier.

**3.30** A cavity barrier shall be tightly fitted and fixed in position. Where this is not possible, e.g. in the case of a junction with slates or profiled sheeting, the junction shall be fire-stopped in accordance with paragraphs 3.37 to 3.39.

The fixing of a cavity barrier shall be such that the performance of the cavity barrier is unlikely to be made ineffective by–

- (a) the movement of the building due to subsidence, shrinkage or thermal change and movement of the external envelope due to wind;
- (b) the collapse in a fire of any service which penetrates it;
- (c) the failure in a fire of its fixings or supporting structure; and
- (d) the failure in a fire of any material or construction which the cavity barrier abuts, e.g. if a cavity barrier is connected to a suspended ceiling, collapse of the ceiling should not cause premature failure of the cavity barrier.

**Diagram 3.4 Cavity barriers at intersections**

see para 3.27(a)

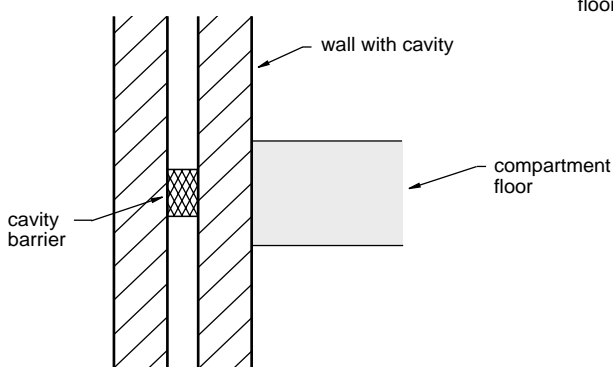

(a) Section

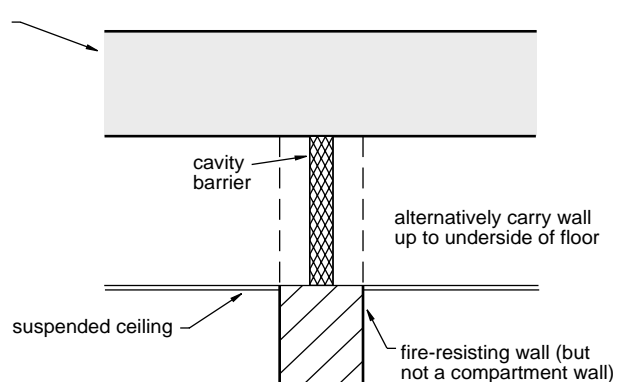

(b) Section

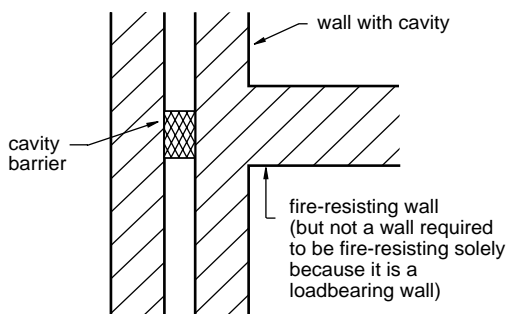

(c) Plan

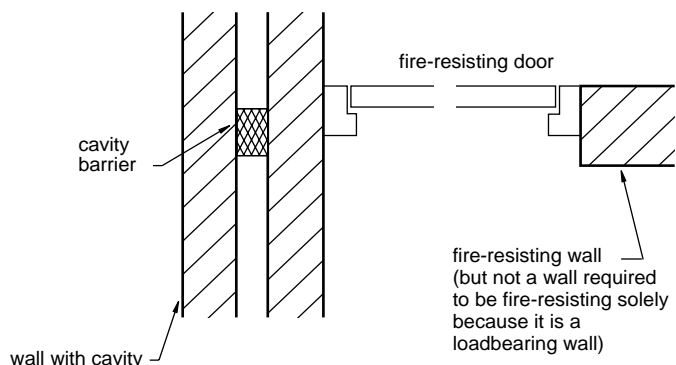

(d) Plan

### Diagram 3.5 Cavity walls excluded from provisions for cavity barriers

see para 3.27(a), 3.31(a) and Table 3.6 items 1.3 & 4

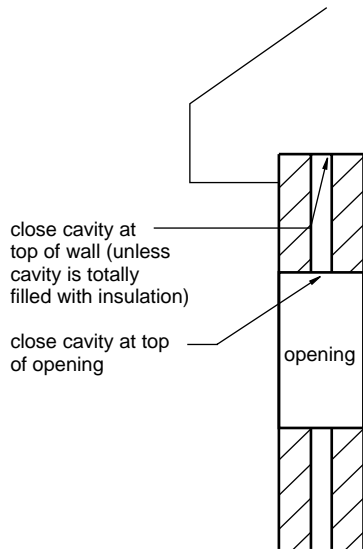

**Section**

external cavity wall of two leaves of brick, block or concrete each at least 75 mm thick – cavity width 100mm maximum

#### Note

Combustible material shall not be placed in or exposed to the cavity except for –

- (a) timber lintels, window or door frames or the ends of timber joists;
- (b) pipe, conduit or cable;
- (c) d.p.c., flashing, cavity closer or wall tie;
- (d) thermal insulating material; or
- (e) a domestic meter cupboard provided that – there are no more than two cupboards per dwelling; the opening in the outer wall leaf is not more than 800 x 500mm for each cupboard; and the inner leaf is not penetrated except by a sleeve not more than 80 x 80mm, which is fire stopped.

### Diagram 3.6 Alternative arrangement of cavity barriers in roof space over a protected stairway in a dwellinghouse of three or more storeys

see para 3.27(a) and Table 3.6 item 2

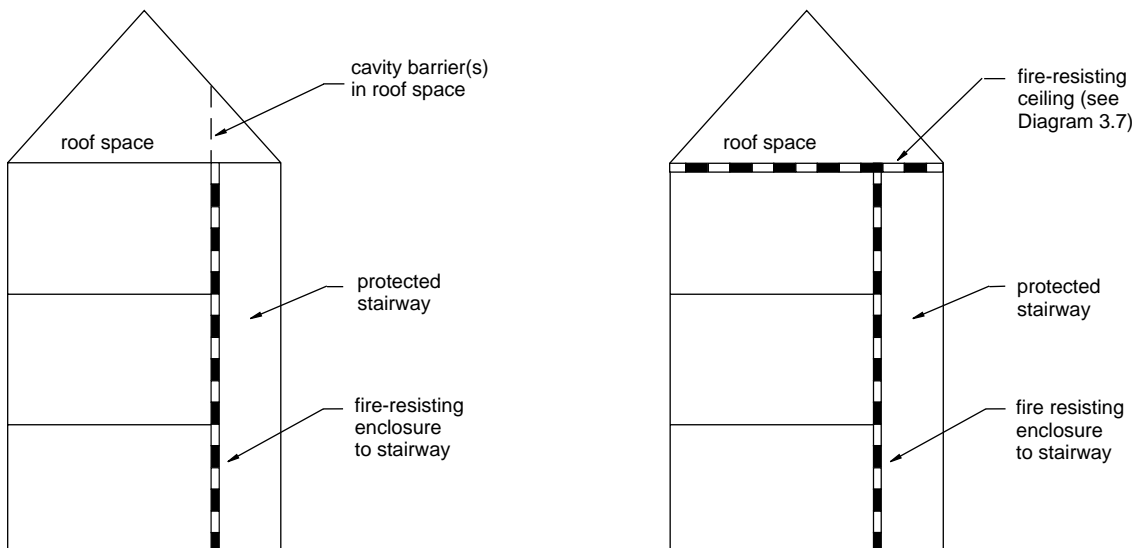

**(a) With cavity barrier(s) as required by Table 3.6**

**(b) Alternative arrangement with fire-resisting ceiling**

## Cavities not requiring subdivision

**3.31** The provisions of paragraph 3.27 (b) shall not apply to a cavity which is–

- (a)** in a masonry or concrete external cavity wall complying with Diagram 3.5;
- (b)** in a floor void or in a roof void where the cavity does not exceed 30 m in extent and is enclosed on its lower side by a fire-resisting ceiling (complying with Diagram 3.7) which extends throughout the building or compartment;
- (c)** below a floor next to the ground where the cavity is not greater than 1 m in height or is not normally accessible by people. However, this shall not apply where there is any opening in the floor such that it is possible for combustible material to accumulate in the cavity (in this case cavity barriers and access for cleaning shall be provided);
- (d)** formed behind the external skin in rain-screen external wall construction, or by over-cladding an existing masonry or concrete external wall or an existing concrete roof, provided that the cavity does not contain combustible insulation and the provisions of Table 3.6 Item 9 are complied with; and
- (e)** between double-skinned, profiled, insulated, roof sheeting provided that –
  - (i) the sheeting is a material of limited combustibility;
  - (ii) both surfaces of the insulation layer have a surface spread of flame classification not lower than Class 1; and
  - (iii) the insulation is in contact with the inner and outer skins of sheeting as shown in Diagram 3.9 (a).

**3.32** Where the cavity is over an undivided room which –

- (a)** exceeds the appropriate maximum dimension for a cavity in Table 3.7, cavity barriers need only be provided on the line of the enclosing walls of that room or at 40 m centres whichever is the lesser; or
- (b)** exceeds 40 m (in either direction on plan) cavity barriers need not be provided where –
  - (i) the room and the cavity together are compartmented from the rest of the building;
  - (ii) an automatic fire detection and alarm system complying with BS 5839: Part 1: 1988 is fitted in the building;
  - (iii) the surface of the ceiling exposed in the cavity is of Class 0 and the ceiling supports and fixings in the cavity are of non-combustible construction;
  - (iv) the surface spread of flame classification of any pipe insulation in the cavity is not lower than Class 1;
  - (v) any electrical wiring in the cavity is laid in metal trays or in metal conduit;
  - (vi) any other material in the cavity is a material of limited combustibility; and
  - (vii) where the cavity is used as a plenum – the recommendations of BS 5588: Part 9: 1989 in relation to recirculating air distribution systems are complied with.

**Diagram 3.7 Fire-resisting ceiling below a cavity**

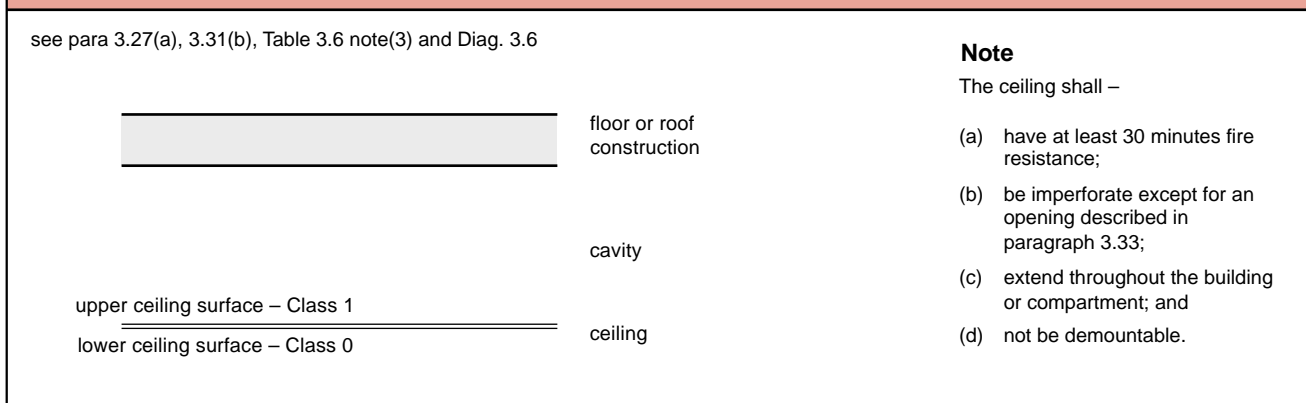

### Diagram 3.8 Alternative arrangements for corridor enclosure

see para 3.27(a) and Table 3.6 note(4)

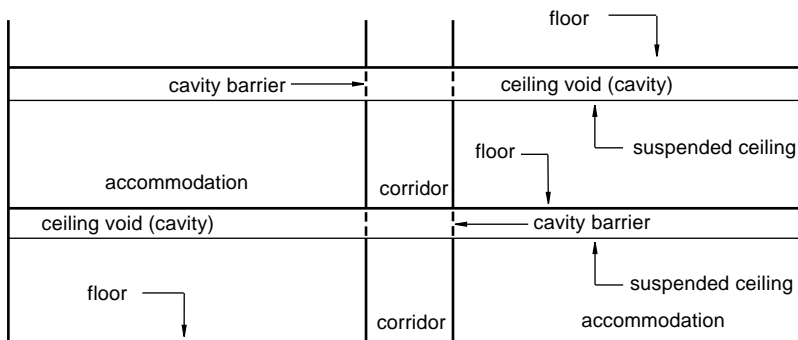

(a) Section showing use of cavity barriers above the corridor enclosure as required by Table 3.6

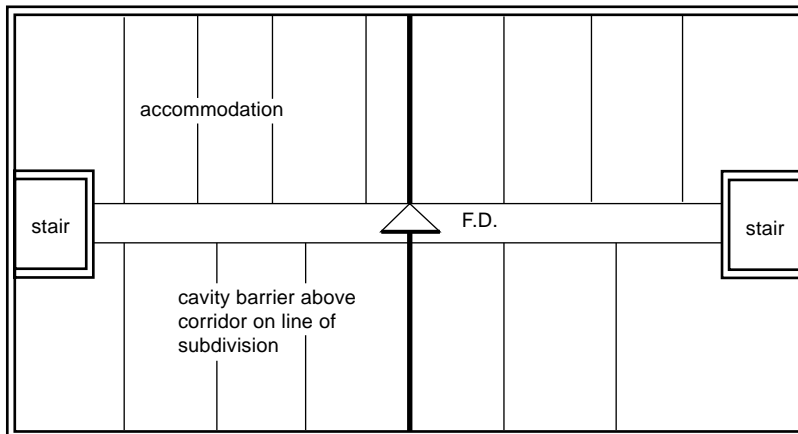

the subdivision is carried full storey height and includes subdivision of the corridor  
a cavity barrier is used in the corridor ceiling void, over the corridor subdivision

**Key**

- fire-resisting door
- fire-resisting construction

(b) Alternative arrangement plan showing subdivision of the storey by fire-resisting construction [see Table 3.6, item 7 and note (4)]

### Diagram 3.9 Provision of cavity barriers in double-skinned profiled insulated roof sheeting

see para 3.31(e)

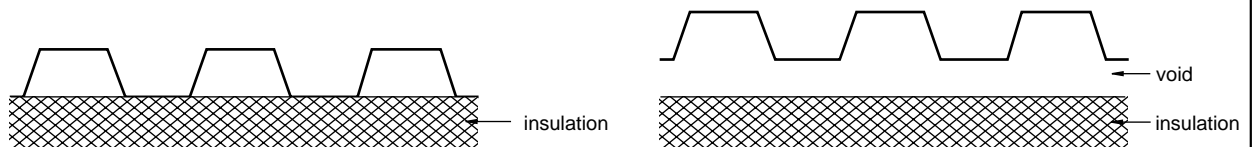

(a) Acceptable without cavity barriers where the insulation is in contact with both skins of the sheeting

(b) Cavity barriers necessary

## Openings in cavity barriers

**3.33** There shall be no openings in a cavity barrier other than those for—

- (a) a fire door which has not less than 30 minutes fire resistance and complies with paragraphs 3.22 to 3.26;
- (b) the passage of a pipe which complies with paragraph 3.34;
- (c) the passage of a cable, a conduit or tray containing one or more cables;
- (d) an opening fitted with a suitably mounted automatic fire shutter; and
- (e) a duct which (unless it is fire-resisting) is fitted with a suitably mounted automatic fire shutter where it passes through the cavity barrier.

(b) where a proprietary sealing system is not used—

- (i) of a diameter not more than the relevant nominal internal diameter given in Table 3.8, with the opening as small as is practicable and fire-stopped around the pipe; or
- (ii) of lead, aluminium, aluminium alloy, fibre-cement or PVC, having a maximum internal diameter not more than 160 mm and be within a non-combustible sleeve [see Table 3.8 Note (1)] as shown in Diagram 3.10.

## Pipes penetrating compartment walls, compartment floors, protected shafts and cavity barriers

**3.34** Where a pipe passes through a compartment wall or a compartment floor (unless the pipe is within a protected shaft) or through a protected shaft or a cavity barrier it shall be—

- (a) provided with a suitable proprietary sealing system which has been shown by test to maintain the fire resistance of the wall, floor or cavity barrier; or

**Diagram 3.10 Pipes penetrating compartment walls, compartment floors, protected shafts and cavity barriers**

see para 3.34(b)

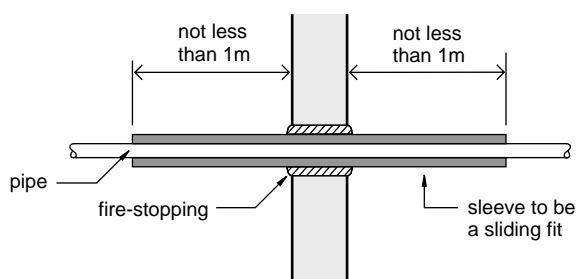

### Note

The opening in the construction to be as small as possible with fire-stopping between sleeve and construction.

**Table 3.8 Maximum nominal internal diameter of pipes passing through compartment walls, compartment floors, protected shafts and cavity barriers**

Situation	Pipe material and maximum nominal internal diameter (mm)		
	Non-combustible material <sup>(1)</sup>	Lead, aluminium aluminium alloy, PVC <sup>(2)</sup> , fibre-cement	Any other material
1 Construction (but not a wall separating buildings) enclosing a protected shaft which is not a stairway or a lift shaft	160	110	40
2 (a) A wall separating dwellinghouses (b) A compartment wall or compartment floor between flats	160	160 (stack pipe) <sup>(3)</sup> 110 (branch pipe) <sup>(3)</sup>	40
3 Any other situation	160	40	40

**Notes –**

- (1) A non-combustible material (such as cast iron or steel) which if exposed to a temperature of 800°C, will not soften or fracture to the extent that flame or hot gas will pass through the wall of the pipe.
- (2) PVC pipes complying with either BS 4514: 1983 or BS 5255:1989.
- (3) These diameters are only in relation to pipes forming part of an above-ground drainage system which is enclosed as shown in Diagram 3.11. In other cases the maximum diameters against Situation 3 apply.

### Ventilation ducts penetrating compartment walls, compartment floors, protected shafts and cavity barriers

**3.35** Where a ventilation or air conditioning duct passes through a compartment wall or compartment floor (unless it is within a protected shaft) or through a protected shaft or a cavity barrier it shall comply with one of the methods for maintaining the fire resistance of the wall, floor or barrier given in BS 5588: Part 9: 1989.

### Flues and heating appliance ventilation ducts penetrating compartment walls and compartment floors

**3.36** Where a flue, a duct containing more than one flue, or an appliance ventilation duct –

(a) passes through a compartment floor or compartment wall; or

(b) is built into a compartment wall,

the walls enclosing the flue or duct shall have a period of fire resistance of not less than half that required for the compartment wall or compartment floor and be of non-combustible construction, as shown in Diagram 3.12.

**Diagram 3.11 Enclosure for drainage or water supply pipes**

see Table 3.8 note(3)

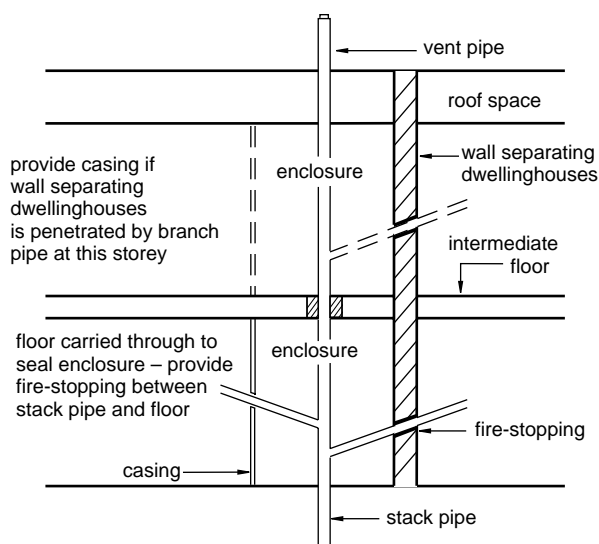

**(a) Dwellinghouse with any number of storeys**

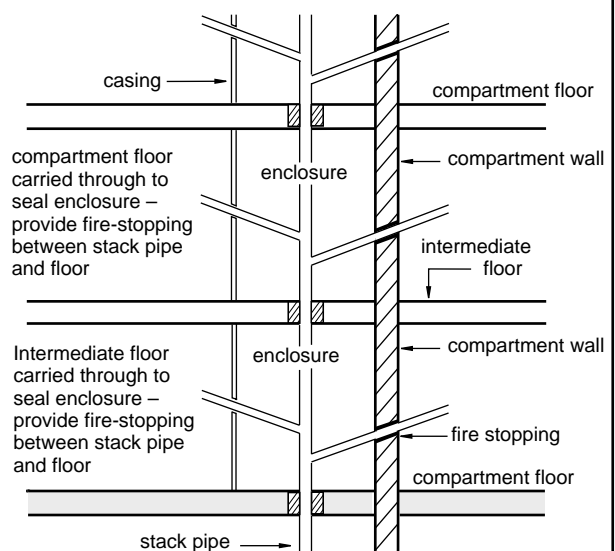

**(b) Other buildings**

**Note**

- (1) The enclosure shall –
  - (a) be bounded by a compartment wall or floor, an outside wall, an intermediate floor or a casing [see specification at (2)];
  - (b) have internal surfaces (except framing members) of Class O;
  - (c) not have an access panel which opens into a circulation space or a bedroom; and
  - (d) be used only for drainage, water supply or vent pipes for a drainage system.
- (2) The casing shall –
  - (a) be imperforate except for an opening for a pipe or an access panel;
  - (b) not to be of sheet metal; and
  - (c) have (including any access panel) not less than 30 minutes fire resistance.
- (3) The opening for a pipe, either in the structure or the casing, shall be as small as possible and fire-stopped around the pipe.

## Diagram 3.12 Flues in compartment walls and compartment floors

see para 3.36

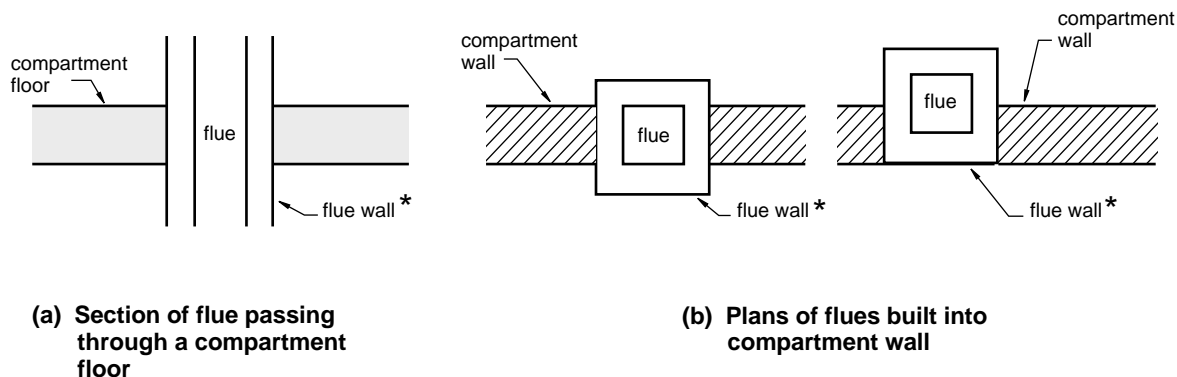

### Note

- \* In all cases flue walls shall have a fire resistance of at least one half of that required for the compartment wall or compartment floor and be of non-combustible construction.

## Fire-stopping

**3.37** In addition to any other provision in this Technical Booklet for fire-stopping, fire-stopping shall be provided at –

- (a) all joints and imperfections of fit between elements which serve as a barrier to the passage of fire; and
- (b) all openings for pipes, ducts, cables, conduits or trays which pass through any element which serves as a barrier to the passage of fire, and such openings shall be –
  - (i) as few in number as possible; and
  - (ii) as small as is practicable.

**3.38** To prevent the displacement of fire-stopping it shall be supported by, or reinforced with, a material of limited combustibility –

- (a) where it is a non-rigid material (unless it has been shown by test not to require such support or reinforcement); and
- (b) in all locations where its unsupported span is more than 100 mm.

**3.39** In addition to proprietary fire-stopping and sealing systems, which have been shown by test to be suitable, the following materials may be suitable as fire-stopping in situations appropriate to the particular material –

cement mortar; gypsum based plaster; cement or gypsum based vermiculite/perlite mixes; glass fibre, crushed rock, blast furnace slag or ceramic based products (with or without resin binders); and intumescent mastics.

---

## Car parks for light vehicles

**3.40** All materials used in the construction of a building, separated part of compartment used for car parking shall be non-combustible other than –

- (a) a surface finish which meets the relevant provisions of Sections 2 and 4 which –
  - (i) is applied to a floor or roof of the car park; and
  - (ii) is applied within any adjoining building, separated part or compartment – to the structure enclosing the car park;
- (b) a fire door; and
- (c) an attendant's kiosk which does not exceed 15 m<sup>2</sup> in area.

## Open-sided car parks

**3.41** A car park may be regarded as an open-sided car park for the purposes of Table 3.2 [i.e. Purpose Group 7 (b) (i)] where, in addition to complying with paragraph 3.40 –

- (a) it has no basement storeys;
- (b) it is naturally ventilated by permanent openings, at each car parking level, having an aggregate ventilation area of not less than 5% of the floor area at that level, with not less than half that ventilation area equally divided in two opposing walls and distributed to provide effective cross-ventilation; and
- (c) where the building is also used for any other purpose – that part forming the car park is a separated part.

## Car parks which are not open-sided

**3.42** Where a car park does not comply with the provisions of paragraph 3.41 it shall not be regarded as open-sided for the purposes of Table 3.2 [i.e. it falls in Purpose Group 7 (b) (ii)]. However, there is a need for ventilation in such a car park, therefore in addition to the provisions of paragraph 3.40 it shall have either –

- (a) natural ventilation at each storey –
  - (i) by permanent openings at each car parking level, having an aggregate ventilation area of not less than 2.5% of the floor area at that level, with not less than half that ventilation area equally divided in two opposing walls and distributed to provide effective cross-ventilation; or

- (ii) by suitable vents at ceiling level on each car parking level having an aggregate area of permanent opening not less than 2.5% of the floor area and so arranged as to have a through flow of air; or

- (b) a system of mechanical ventilation where –
    - (i) the system is independent of any other ventilation system and designed to operate at 6 air changes per hour for normal extraction and at 10 air changes per hour in a fire condition;
    - (ii) the system is designed to operate in two parts, each capable of extracting 50% of the rates set out in (i) above and designed so that each part may operate singly or simultaneously; each part of the system shall have an independent power supply which will operate in the event of failure of the main supply;
    - (iii) extract points are arranged so that 50% are at high level and 50% at low level; and
    - (iv) the fans are rated to run at 300°C for not less than 60 minutes, and the ductwork and fixings are constructed of materials having a melting point of not less than 800°C.
-

# Section 4 – External fire spread

**4.1** This Section contains provisions relating to the design and construction of –

**(a)** external walls – in order that the risk of ignition from an external source, the spread of flame over the external surface and the spread of fire from one building to another are restricted; and

**(b)** roofs – in order that the risk of spread of flame and of fire penetration from an external source are restricted.

## Construction of external walls

**4.2** The external walls of a building are elements of structure and other than those areas which may be unprotected (as determined in accordance with paragraphs 4.8 to 4.10) shall have the appropriate period of fire resistance given in Section 3.

**4.3** The external surface of a wall shall meet the requirements given in Table 4.1 relevant to the height of the building and the distance between the building and the relevant boundary. The provisions of Table 4.1 are illustrated in Diagram 4.1.

In the case of the external wall being of “rainscreen” construction (i.e. an outer cladding with a drained and ventilated cavity behind) the surface of the outer cladding which faces the cavity shall also meet the relevant requirements of Table 4.1.

**Table 4.1 Provisions for external surfaces of walls**

Maximum height of building (m)	Distance of wall from any point on the relevant boundary	
	Less than 1 m	1 m or more
Less than 20	Class 0	(a) Purpose Group 5 – no requirement other than as described in Note 1 (b) All other purpose groups – no requirement
20 or more	Class 0	(a) Surfaces 20 m or more above ground level – Class 0 (b) Surfaces less than 20 m above ground level – see Note 2

**Notes –**

- (1) In a Purpose Group 5 building of more than one storey any part of a wall which is less than 10 m above –
  - (a) the ground;
  - (b) a roof to which the public have access; or
  - (c) any other part of the building to which the public have access,
 shall have an index of performance (I) of not more than 20 when tested to BS 476: Part 6: 1981 or 1989, or be timber cladding at least 9 mm thick.
- (2) Surfaces less than 20 m above the ground may be of any material which has an index of performance (I) of not more than 20 when tested to BS 476: Part 6: 1981 or 1989, or be timber cladding at least 9 mm thick.

## Diagram 4.1 Provisions for external surfaces of walls

see para 4.3

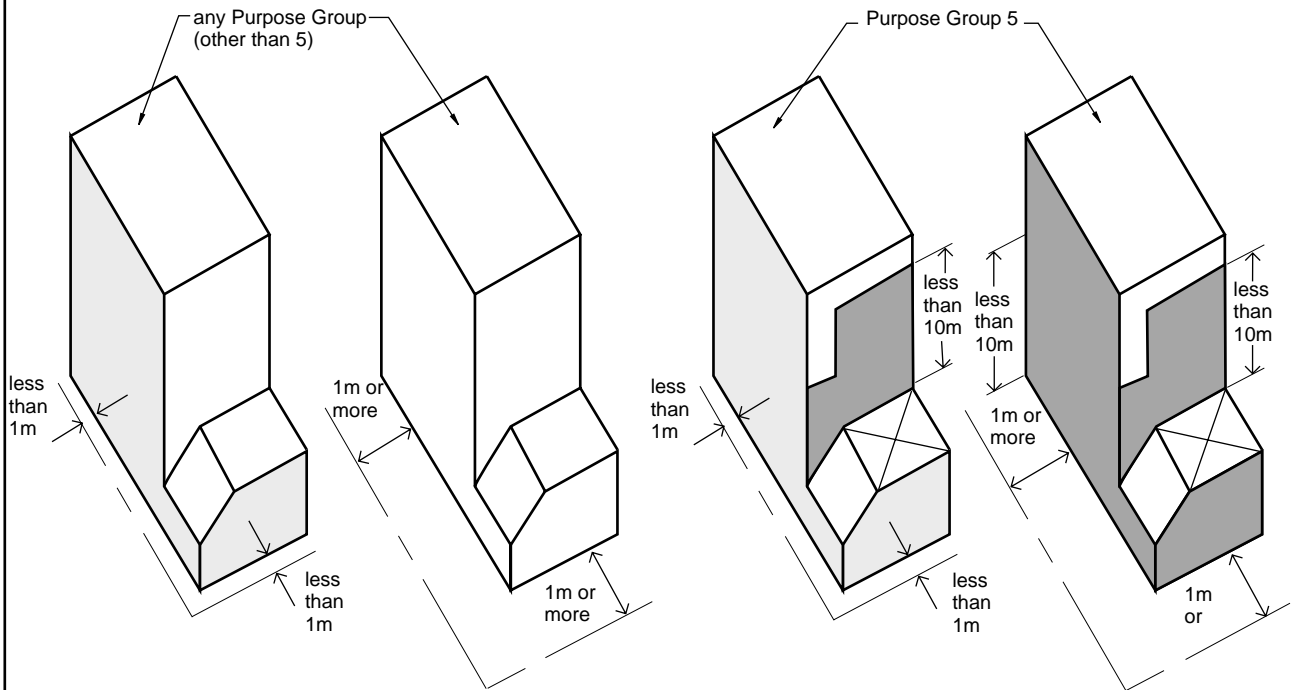

Maximum height of building – less than 20m

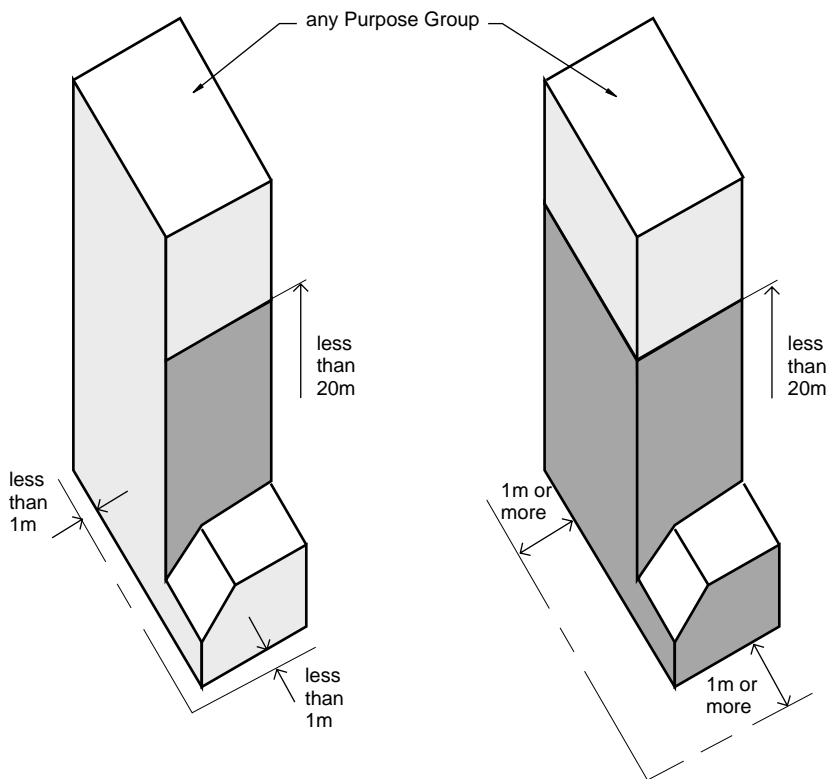

Maximum height of building – 20m or more

### Key

--- relevant boundary

 roof to which the public have access

 Class O

 no provision in respect of the boundary indicated

 index (I) not more than 20, or timber cladding at least 9mm thick

---

**4.4** Where a building has a storey the floor of which is 20 m or more above ground level any materials used for supporting cladding and any insulation material incorporated within the wall construction (other than a masonry cavity wall complying with Diagram 3.4) shall be a material of limited combustibility. [Advice on the incorporation of thermal insulation in such walls is given in Building Research Establishment Report – Fire performance of external thermal insulation for walls of multi-storey buildings (BR135: 1988).]

### **Portal frames**

**4.5** Frequently, the provisions of Section 3 do not require the portal frames of a single storey building to have fire resistance except where the column members of those frames are within, or support, an external wall, which under paragraph 4.2, is required to have fire resistance. Where this occurs both the column and rafter members shall have fire resistance, as the moment-resisting connections mean the portal frame acts as a single element. However, in the case of a steel portal frame which has been designed in accordance with the method set out in Fire and steel construction: The Behaviour of Steel Portal Frames in Boundary Conditions: 1990 (2nd Edition), only those members within or supporting an external wall requiring fire resistance, need have fire resistance.

### **Space separation – External walls**

**4.6** Protection against the external spread of fire from one building to another is related to –

- (i) the distance between a building and each of its relevant boundaries (see paragraph 4.7); and
- (ii) the extent of the unprotected area in the side of the building which faces that boundary.

The basic provisions are outlined in paragraph 4.11 and methods of meeting those provisions are given in paragraphs 4.12 to 4.16.

The provisions are based on a number of assumptions, and whilst some of these may differ from the circumstances of a particular case, together they enable a reasonable standard of space separation to be achieved.

The provisions limit the extent of openings and other unprotected areas in the sides of a building (including areas with a combustible surface) which would not give adequate protection against the external spread of fire from one building to another.

The assumptions for establishing space separation are –

- (a) that the fire will involve a complete compartment but will not spread to other compartments;
- (b) that the intensity of a fire is related to the use of the building and will be moderated by a sprinkler system where it is provided;
- (c) that a building, which has an identical elevation, is located on the opposite side of, and at the same distance from, the relevant boundary; and
- (d) that radiation from that part of the external wall, which has the fire resistance required by Section 3, is discounted unless its external surface is combustible as described in paragraph 4.8.

### **Boundaries**

**4.7** For a boundary to be a relevant boundary it shall coincide with, be parallel to or be at an angle of not more than 80° to the side of the building (see Diagram 4.2).

A relevant boundary may be –

- (a) the actual boundary of the premises on which the building is located;
- (b) the centre line of a road, river, canal or railway which adjoins the actual boundary; or
- (c) a notional boundary established where two or more buildings (one of which is of Purpose Group 1, 2 or 5) are to share the same site. A notional boundary shall be assumed so that both buildings comply with the space separation distances required by this Section.

Where a notional boundary is to be established and one of the buildings is an existing building, that building shall be treated as if it were a new building.

## Diagram 4.2 Relevant boundaries

see para 4.7

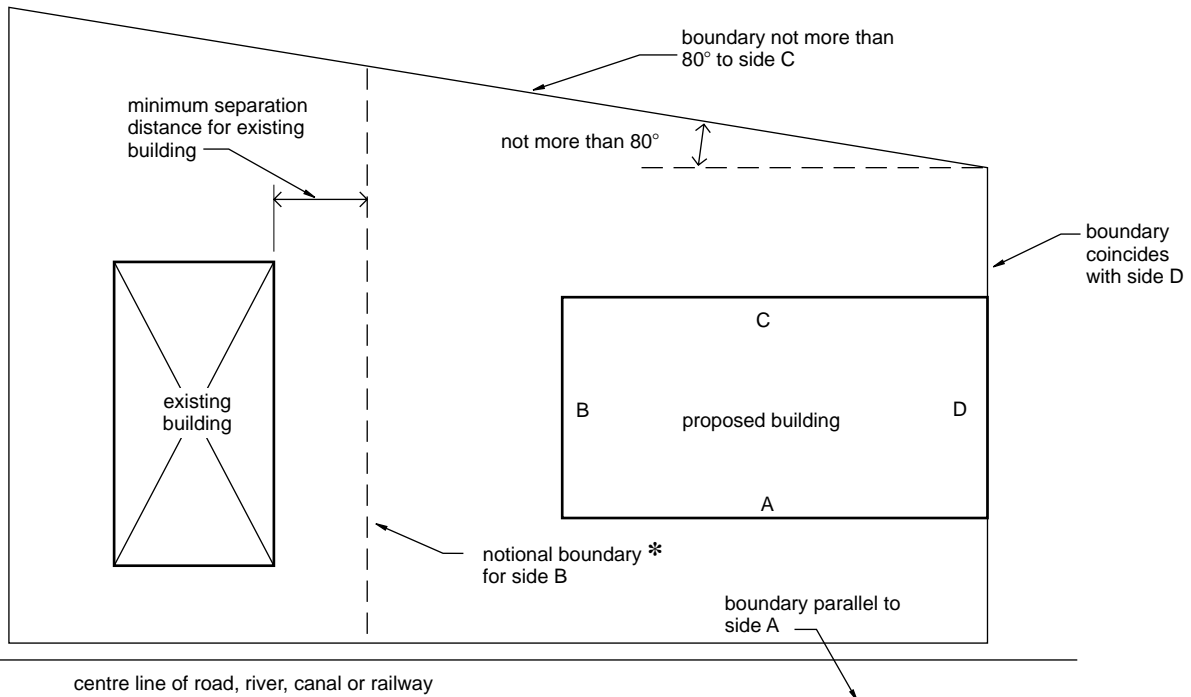

### Note

\* Notional boundary is only established where one or both of the buildings is of Purpose Group 1, 2 or 5.

## Unprotected areas in external walls

**4.8** Any part of an external wall which has less fire resistance than that required by Section 3 shall be considered to be an unprotected area.

Where an external wall has the appropriate fire resistance but has a combustible material more than 1 mm thick as its external surface, that wall shall be considered to be an unprotected area amounting to half the actual area of the combustible material. Such an unprotected area shall be considered to be centrally located on the actual area of combustible material as shown in Diagram 4.3.

Any part of the external wall of a protected stairway shall be discounted when calculating unprotected areas. (However, Section 1 and Section 5 contain provisions relating to the relationship between the external walls of protected stairways and the unprotected areas of other parts of the building.)

Small unprotected areas may be discounted where they occur in an otherwise protected area of wall, provided that they do not exceed the areas and comply with the minimum spacing shown in Diagram 4.4.

## Diagram 4.3 Combustible material on external walls

see para 4.8

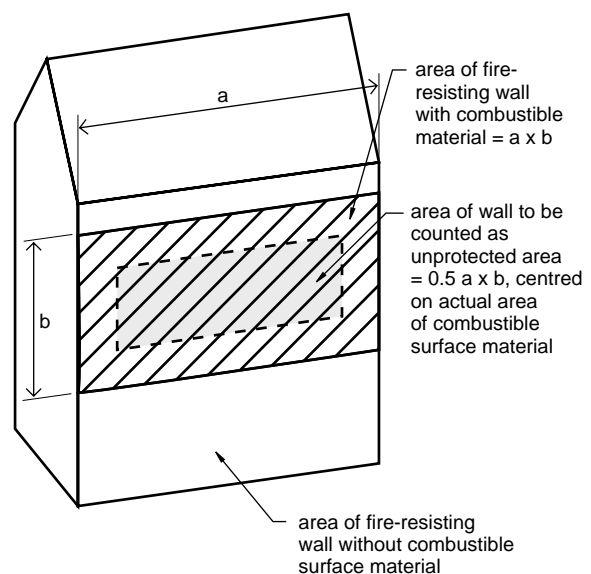

**4.9** An external wall situated within 1 m of any point on its relevant boundary shall have no unprotected areas other than those shown in Diagram 4.4.

**4.10** An external wall situated 1 m or more from any point on its relevant boundary may have unprotected areas provided that their total area does not exceed that given by the most favourable calculation method given in paragraphs 4.11 to 4.16. Where a building is uncomparted any part of an external wall which is more than 30 m above ground level may be discounted in the calculation.

**Diagram 4.4 Unprotected areas which may be discounted**

see para 4.8, 4.9 and 4.14

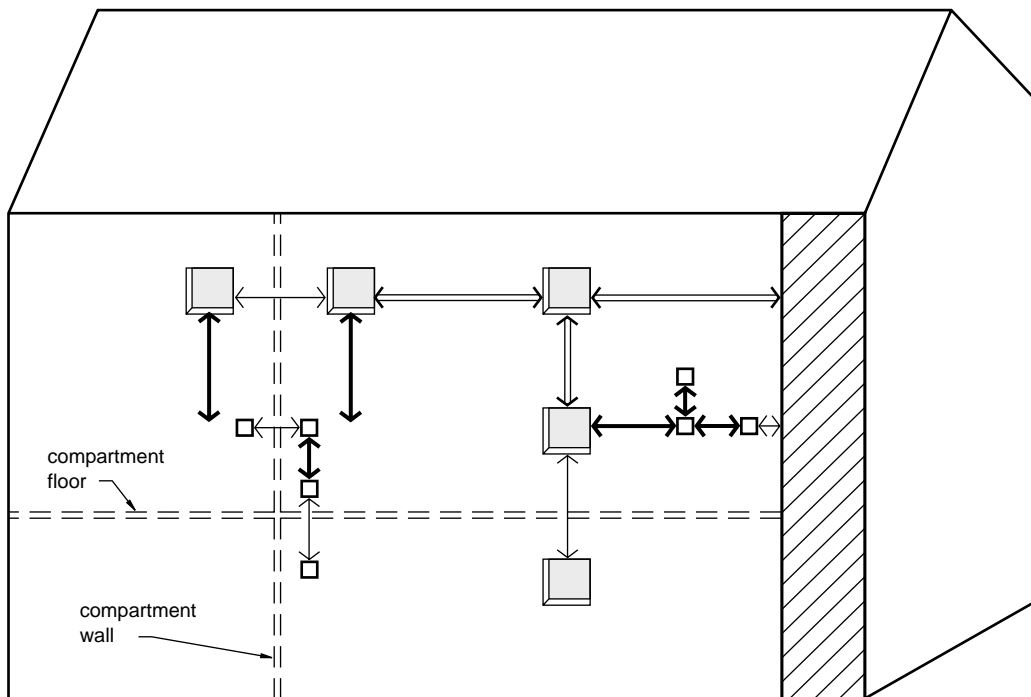

**Key**



an unprotected area of not more than 1m<sup>2</sup> which may consist of two or more smaller areas amounting to not more than 1m<sup>2</sup> within an area of 1m x 1m



an unprotected area of not more than 0.1m<sup>2</sup>



the external wall of a protected stairway

**Dimensional restrictions**

←→ 4m minimum distance

←→ 1.5m minimum distance

←→ dimension not restricted

## Provisions for and calculation of space separation and unprotected areas

**4.11** A building shall be separated from its relevant boundaries by at least half the distance at which the total thermal radiation intensity received from all unprotected areas in the external walls would be  $12.6 \text{ kW/m}^2$  (in still air) assuming the radiation intensity at each unprotected area is –

**(a)**  $84 \text{ kW/m}^2$  where the building is of Purpose Group 1, 2, 3, 5 or 7 (b); or

**(b)**  $168 \text{ kW/m}^2$  where the building is of any other purpose group.

Where a building is compartmented each compartment shall be calculated separately.

Where a building or compartment is fitted throughout with a sprinkler system complying with the relevant provisions of BS 5306: Part 2: 1990 for the appropriate occupancy, the thermal radiation intensities in (a) and (b) and the distances calculated using the methods given in paragraphs 4.13 to 4.16 may be halved subject to there being a minimum distance of 1 m.

**4.12** Building Research Establishment Report – External fire spread: building separation and boundary distances (BR187: 1991) gives the method by which the thermal radiation intensity shall be calculated for paragraph 4.11. It also gives detailed explanations, with worked examples, of Method 3 (paragraph 4.15) and Method 4 (paragraph 4.16).

### Method 1 (Small residential buildings)

**4.13** This method may only be used for buildings in Purpose Groups 1 and 2 (b) which do not exceed three storeys in height and are not more than 24 m in length. The maximum total area of unprotected areas in the side of a building shall not exceed that given in Table 4.2 for the relevant minimum distance between that side and its boundary.

**Table 4.2 Unprotected areas in small residential buildings (Method 1)**

Minimum distance between side of building and relevant boundary (m)	Maximum total area of unprotected areas (m <sup>2</sup> )
1	5.6
2	12
3	18
4	24
5	30
6	No limit

### Method 2 (Small buildings and compartments)

**4.14** This method may be used for buildings and compartments of any purpose group which do not exceed 10 m in height [this height limit does not apply to buildings of Purpose Group 7 (b)]. The maximum total percentage of unprotected area in the side of a building shall not exceed that given in Table 4.3 for the appropriate purpose group and minimum distance between that side and its relevant boundary. When calculating the unprotected area any area which complies with paragraph 4.8 and Diagram 4.4 may be discounted.

**Table 4.3 Unprotected areas in small buildings and compartments (Method 2)**

Minimum distance between side of building and relevant boundary (m)		Maximum total percentage of unprotected area (%)
Purpose groups		
1, 2, 3 and 5	4, 6 and 7 *	
N/A	1	4
1	2	8
2.5	5	20
5	10	40
7.5	15	60
10	20	80
12.5	25	100

**Notes –**

- \* In the case of a car park in Purpose Group 7(b) the distances given for Purpose Groups 1, 2, 3 and 5 may be used.
- N/A = not applicable.
- Intermediate values may be obtained by interpolation.

**Method 3 (Enclosing rectangle) –**

**4.15** This method may be used for buildings and compartments of any purpose group. A building or compartment shall be so situated that no point on its relevant boundary is –

- (a) between the relevant plane of reference and the side of the building; and
- (b) closer to the relevant plane of reference than that given in Table 4.4 for the appropriate purpose group, dimensions of enclosing rectangle and unprotected area percentage.

A plane of reference is a vertical plane which touches the side, or some part of the side, of a building or compartment but which (however, far extended) does not pass within the structure (excluding balconies, copings and similar projections) of that building or compartment. The relevant plane of reference shall be chosen to give the least separation distance between it and the relevant boundary. Normally, it will be best for the plane of reference to be parallel to the relevant boundary.

The enclosing rectangle is the rectangle, of the least width and height given in Table 4.4, on the relevant plane of reference, which will –

- (i) enclose all the outer edges of the unprotected areas in the external wall of the building or compartment (other than any which is at an angle of 80° or more to the plane of reference). The outer edges shall be projected to the plane of reference by lines perpendicular to such plane; and
- (ii) have two horizontal sides.

The total unprotected area is found by adding the areas, as projected on the plane of reference, of all unprotected areas.

The unprotected percentage is calculated from –

$$\text{unprotected percentage} = \frac{\text{total unprotected area}}{\text{enclosing rectangle area}} \times 100$$

The minimum distance from the plane of reference to the relevant boundary is given in Table 4.4, and where the unprotected percentage is between the values given in the Table the distance may be obtained by linear interpolation.

**Table 4.4 Permitted unprotected percentages in relation to enclosing rectangles (Method 3)**

Width of enclosing rectangle (m)	Distance from relevant boundary for unprotected percentage not exceeding								
	20%	30%	40%	50%	60%	70%	80%	90%	100%
	Minimum boundary distance (m) – figures in brackets are for Purpose Groups 1, 2, 3, 5 and 7(b)								
<b>Enclosing rectangle 3 m high</b>									
3	1.0(1.0)	1.5(1.0)	2.0(1.0)	2.0(1.5)	2.5(1.5)	2.5(1.5)	2.5(2.0)	3.0(2.0)	3.0(2.0)
6	1.5(1.0)	2.0(1.0)	2.5(1.5)	3.0(2.0)	3.0(2.0)	3.5(2.0)	3.5(2.5)	4.0(2.5)	4.0(3.0)
9	1.5(1.0)	2.5(1.0)	3.0(1.5)	3.5(2.0)	4.0(2.5)	4.0(2.5)	4.5(3.0)	5.0(3.0)	5.0(3.5)
12	2.0(1.0)	2.5(1.5)	3.0(2.0)	3.5(2.0)	4.0(2.5)	4.5(3.0)	5.0(3.0)	5.5(3.5)	5.5(3.5)
15	2.0(1.0)	2.5(1.5)	3.5(2.0)	4.0(2.5)	4.5(2.5)	5.0(3.0)	5.5(3.5)	6.0(3.5)	6.0(4.0)
18	2.0(1.0)	2.5(1.5)	3.5(2.0)	4.0(2.5)	5.0(2.5)	5.0(3.0)	6.0(3.5)	6.5(4.0)	6.5(4.0)
21	2.0(1.0)	3.0(1.5)	3.5(2.0)	4.5(2.5)	5.0(3.0)	5.5(3.0)	6.0(3.5)	6.5(4.0)	7.0(4.5)
24	2.0(1.0)	3.0(1.5)	3.5(2.0)	4.5(2.5)	5.0(3.0)	5.5(3.5)	6.0(3.5)	7.0(4.0)	7.5(4.5)
27	2.0(1.0)	3.0(1.5)	4.0(2.0)	4.5(2.5)	5.5(3.0)	6.0(3.5)	6.5(4.0)	7.0(4.0)	7.5(4.5)
30	2.0(1.0)	3.0(1.5)	4.0(2.0)	4.5(2.5)	5.5(3.0)	6.0(3.5)	6.5(4.0)	7.5(4.0)	8.0(4.5)
40	2.0(1.0)	3.0(1.5)	4.0(2.0)	5.0(2.5)	5.5(3.0)	6.5(3.5)	7.0(4.0)	8.0(4.0)	8.5(5.0)
50	2.0(1.0)	3.0(1.5)	4.0(2.0)	5.0(2.5)	6.0(3.0)	6.5(3.5)	7.5(4.0)	8.0(4.0)	9.0(5.0)
60	2.0(1.0)	3.0(1.5)	4.0(2.0)	5.0(2.5)	6.0(3.0)	7.0(3.5)	7.5(4.0)	8.5(4.0)	9.5(5.0)
80	2.0(1.0)	3.0(1.5)	4.0(2.0)	5.0(2.5)	6.0(3.0)	7.0(3.5)	8.0(4.0)	9.0(4.0)	9.5(5.0)
No limit	2.0(1.0)	3.0(1.5)	4.0(2.0)	5.0(2.5)	6.0(3.0)	7.0(3.5)	8.0(4.0)	9.0(4.0)	10.0(5.0)
<b>Enclosing rectangle 6 m high</b>									
3	1.5(1.0)	2.0(1.0)	2.5(1.5)	3.0(2.0)	3.0(2.0)	3.5(2.0)	3.5(2.5)	4.0(2.5)	4.0(3.0)
6	2.0(1.0)	3.0(1.5)	3.5(2.0)	4.0(2.5)	4.5(3.0)	5.0(3.0)	5.5(3.5)	5.5(4.0)	6.0(4.0)
9	2.5(1.0)	3.5(2.0)	4.5(2.5)	5.0(3.0)	5.5(3.5)	6.0(4.0)	6.0(4.5)	7.0(4.5)	7.0(5.0)
12	3.0(1.5)	4.0(2.5)	5.0(3.0)	5.5(3.5)	6.5(4.0)	7.0(4.5)	7.5(5.0)	8.0(5.0)	8.5(5.5)
15	3.0(1.5)	4.5(2.5)	5.5(3.0)	6.0(4.0)	7.0(4.5)	7.5(5.0)	8.0(5.5)	9.0(5.5)	9.0(6.0)
18	3.5(1.5)	4.5(2.5)	5.5(3.5)	6.5(4.0)	7.5(4.5)	8.0(5.0)	9.0(5.5)	9.5(6.0)	10.0(6.5)
21	3.5(1.5)	5.0(2.5)	6.0(3.5)	7.0(4.0)	8.0(5.0)	9.0(5.5)	9.5(6.0)	10.0(6.5)	10.5(7.0)
24	3.5(1.5)	5.0(2.5)	6.0(3.5)	7.0(4.5)	8.5(5.0)	9.5(5.5)	10.0(6.0)	10.5(7.0)	11.0(7.0)
27	3.5(1.5)	5.0(2.5)	6.5(3.5)	7.5(4.5)	8.5(5.0)	9.5(6.0)	10.5(6.5)	11.0(7.0)	12.0(7.5)
30	3.5(1.5)	5.0(2.5)	6.5(3.5)	8.0(4.5)	9.0(5.0)	10.0(6.0)	11.0(6.5)	12.0(7.0)	12.5(8.0)
40	3.5(1.5)	5.5(2.5)	7.0(3.5)	8.5(4.5)	10.0(5.5)	11.0(6.5)	12.0(7.0)	13.0(8.0)	14.0(8.5)
50	3.5(1.5)	5.5(2.5)	7.5(3.5)	9.0(4.5)	10.5(5.5)	11.5(6.5)	13.0(7.5)	14.0(8.0)	15.0(9.0)
60	3.5(1.5)	5.5(2.5)	7.5(3.5)	9.5(5.0)	11.0(5.5)	12.0(6.5)	13.5(7.5)	15.0(8.5)	16.0(9.5)
80	3.5(1.5)	6.0(2.5)	7.5(3.5)	9.5(5.0)	11.5(6.0)	13.0(7.0)	14.5(7.5)	16.0(8.5)	17.5(9.5)
100	3.5(1.5)	6.0(2.5)	8.0(3.5)	10.0(5.0)	12.0(6.0)	13.5(7.0)	15.0(8.0)	16.5(8.5)	18.0(10.0)
120	3.5(1.5)	6.0(2.5)	8.0(3.5)	10.0(5.0)	12.0(6.0)	14.0(7.0)	15.5(8.0)	17.0(8.5)	19.0(10.0)
No limit	3.5(1.5)	6.0(2.5)	8.0(3.5)	10.0(5.0)	12.0(6.0)	14.0(7.0)	16.0(8.0)	18.0(8.5)	19.0(10.0)

**Table 4.4 Permitted unprotected percentages in relation to enclosing rectangles (Method 3)**

Width of enclosing rectangle (m)	Distance from relevant boundary for unprotected percentage not exceeding								
	20%	30%	40%	50%	60%	70%	80%	90%	100%
	Minimum boundary distance (m) – figures in brackets are for Purpose Groups 1, 2, 3, 5 and 7(b)								
<b>Enclosing rectangle 9 m high</b>									
3	1.5(1.0)	2.5(1.0)	3.0(1.5)	3.5(2.0)	4.0(2.5)	4.0(2.5)	4.5(3.0)	5.0(3.0)	5.0(3.5)
6	2.5(1.0)	3.5(2.0)	4.5(2.5)	5.0(3.0)	5.5(3.5)	6.0(4.0)	6.5(4.5)	7.0(4.5)	7.0(5.0)
9	3.5(1.5)	4.5(2.5)	5.5(3.5)	6.0(4.0)	6.5(4.5)	7.5(5.0)	8.0(5.5)	8.5(5.5)	9.0(6.0)
12	3.5(1.5)	5.0(3.0)	6.0(3.5)	7.0(4.5)	7.5(5.0)	8.5(5.5)	9.0(6.0)	9.5(6.5)	10.5(7.0)
15	4.0(2.0)	5.5(3.0)	6.5(4.0)	7.5(5.0)	8.5(5.5)	9.5(6.0)	10.0(6.5)	11.0(7.0)	11.5(7.5)
18	4.5(2.0)	6.0(3.5)	7.0(4.5)	8.5(5.0)	9.5(6.0)	10.0(6.5)	11.0(7.0)	12.0(8.0)	12.5(8.5)
21	4.5(2.0)	6.5(3.5)	7.5(4.5)	9.0(5.5)	10.0(6.5)	11.0(7.0)	12.0(7.5)	13.0(8.5)	13.5(9.0)
24	5.0(2.0)	6.5(3.5)	8.0(5.0)	9.5(5.5)	11.0(6.5)	12.0(7.5)	13.0(8.0)	13.5(9.0)	14.5(9.5)
27	5.0(2.0)	7.0(3.5)	8.5(5.0)	10.0(6.0)	11.5(7.0)	12.5(7.5)	13.5(8.5)	14.5(9.5)	15.0(10.0)
30	5.0(2.0)	7.0(3.5)	9.0(5.0)	10.5(6.0)	12.0(7.0)	13.0(8.0)	14.0(9.0)	15.0(9.5)	16.0(10.5)
40	5.5(2.0)	7.5(3.5)	9.5(5.5)	11.5(6.5)	13.0(7.5)	14.5(8.5)	15.5(9.5)	17.0(10.5)	17.5(11.5)
50	5.5(2.0)	8.0(4.0)	10.0(5.5)	12.5(6.5)	14.0(8.0)	15.5(9.0)	17.0(10.0)	18.5(11.5)	19.5(12.5)
60	5.5(2.0)	8.0(4.0)	11.0(5.5)	13.0(7.0)	15.0(8.0)	16.5(9.5)	18.0(11.0)	19.5(11.5)	21.0(13.0)
80	5.5(2.0)	8.5(4.0)	11.5(5.5)	13.5(7.0)	16.0(8.5)	17.5(10.0)	19.5(11.5)	21.5(12.5)	23.0(13.5)
100	5.5(2.0)	8.5(4.0)	11.5(5.5)	14.5(7.0)	16.5(8.5)	18.5(10.0)	21.0(11.5)	22.5(12.5)	24.5(14.5)
120	5.5(2.0)	8.5(4.0)	11.5(5.5)	14.5(7.0)	17.0(8.5)	19.5(10.0)	21.5(11.5)	23.5(12.5)	26.0(14.5)
No Limit	5.5(2.0)	8.5(4.0)	11.5(5.5)	15.0(7.0)	17.5(8.5)	20.0(10.5)	22.5(12.0)	24.5(12.5)	27.0(15.0)
<b>Enclosing rectangle 12 m high</b>									
3	2.0(1.0)	2.5(1.5)	3.0(2.0)	3.5(2.0)	4.0(2.5)	4.5(3.0)	5.0(3.0)	5.5(3.5)	5.5(3.5)
6	3.0(1.5)	4.0(2.5)	5.0(3.0)	5.5(3.5)	6.5(4.0)	7.0(4.5)	7.5(5.0)	8.0(5.0)	8.5(5.5)
9	3.5(1.5)	5.0(3.0)	6.0(3.5)	7.0(4.5)	7.5(5.0)	8.5(5.5)	9.0(6.0)	9.5(6.5)	10.5(7.0)
12	4.5(1.5)	6.0(3.5)	7.0(4.5)	8.0(5.0)	9.0(6.0)	9.5(6.5)	11.0(7.0)	11.5(7.5)	12.0(8.0)
15	5.0(2.0)	6.5(3.5)	8.0(5.0)	9.0(5.5)	10.0(6.5)	11.0(7.0)	12.0(8.0)	13.0(8.5)	13.5(9.0)
18	5.0(2.5)	7.0(4.0)	8.5(5.0)	10.0(6.0)	11.0(7.0)	12.0(7.5)	13.0(8.5)	14.0(9.0)	14.5(10.0)
21	5.5(2.5)	7.5(4.0)	9.0(5.5)	10.5(6.5)	12.0(7.5)	13.0(8.5)	14.0(9.0)	15.0(10.0)	16.0(10.5)
24	6.0(2.5)	8.0(4.5)	9.5(6.0)	11.5(7.0)	12.5(8.0)	14.0(8.5)	15.0(9.5)	16.0(10.5)	16.5(11.5)
27	6.0(2.5)	8.0(4.5)	10.5(6.0)	12.0(7.0)	13.5(8.0)	14.5(9.0)	16.0(10.5)	17.0(11.0)	17.5(12.0)
30	6.5(2.5)	8.5(4.5)	10.5(6.5)	12.5(7.5)	14.0(8.5)	15.0(9.5)	16.5(10.5)	17.5(11.5)	18.5(12.5)
40	6.5(2.5)	9.5(5.0)	12.0(6.5)	14.0(8.0)	15.5(9.5)	17.5(10.5)	18.5(12.0)	20.0(13.0)	21.0(14.0)
50	7.0(2.5)	10.0(5.0)	13.0(7.0)	15.0(8.5)	17.0(10.0)	19.0(11.0)	20.5(13.0)	23.0(14.0)	23.0(15.0)
60	7.0(2.5)	10.5(5.0)	13.5(7.0)	16.0(9.0)	18.0(10.5)	20.0(12.0)	21.5(13.5)	23.5(14.5)	25.0(16.0)
80	7.0(2.5)	11.0(5.0)	14.5(7.0)	17.0(9.0)	19.5(11.0)	21.5(13.0)	23.5(14.5)	26.0(16.0)	27.5(17.0)
100	7.5(2.5)	11.5(5.0)	15.0(7.5)	18.0(9.5)	21.0(11.5)	23.0(13.5)	25.5(15.0)	28.0(16.5)	30.0(18.0)
120	7.5(2.5)	11.5(5.0)	15.0(7.5)	18.5(9.5)	22.0(11.5)	24.0(13.5)	27.0(15.0)	29.5(17.0)	31.5(18.5)
No limit	7.5(2.5)	12.0(5.0)	15.5(7.5)	19.0(9.5)	22.5(12.0)	25.0(14.0)	28.0(15.5)	30.5(17.0)	34.0(19.0)

**Table 4.4 Permitted unprotected percentages in relation to enclosing rectangles (Method 3)**

Width of enclosing rectangle (m)	Distance from relevant boundary for unprotected percentage not exceeding								
	20%	30%	40%	50%	60%	70%	80%	90%	100%
	Minimum boundary distance (m) – figures in brackets are for Purpose Groups 1, 2, 3, 5 and 7(b)								
<b>Enclosing rectangle 15 m high</b>									
3	2.0(1.0)	2.5(1.5)	3.5(2.0)	4.0(2.5)	4.5(2.5)	5.0(3.0)	5.5(3.5)	6.0(3.5)	6.0(4.0)
6	3.0(1.5)	4.5(2.5)	5.5(3.0)	6.0(4.0)	7.0(4.5)	7.5(5.0)	8.0(5.5)	9.0(5.5)	9.0(6.0)
9	4.0(2.0)	5.5(3.0)	6.5(4.0)	7.5(5.0)	8.5(5.5)	9.5(6.0)	10.0(6.5)	11.0(7.0)	11.5(7.5)
12	5.0(2.0)	6.5(3.5)	8.0(5.0)	9.0(5.5)	10.0(6.5)	11.0(7.0)	12.0(8.0)	13.0(8.5)	13.5(9.0)
15	5.5(2.0)	7.0(4.0)	9.0(5.5)	10.0(6.5)	11.5(7.0)	12.5(8.0)	13.5(9.0)	14.5(9.5)	15.0(10.0)
18	6.0(2.5)	8.0(4.5)	9.5(6.0)	11.0(7.0)	12.5(8.0)	13.5(8.5)	14.5(9.5)	15.5(10.5)	16.5(11.0)
21	6.5(2.5)	8.5(5.0)	10.5(6.5)	12.0(7.5)	13.5(8.5)	14.5(9.5)	16.0(10.5)	16.5(11.0)	17.5(12.0)
24	6.5(3.0)	9.0(5.0)	11.0(6.5)	13.0(8.0)	14.5(9.0)	15.5(10.0)	17.0(11.0)	18.0(12.0)	19.0(13.0)
27	7.0(3.0)	9.5(5.5)	11.5(7.0)	13.5(8.5)	15.0(9.5)	16.5(10.5)	18.0(11.5)	19.0(12.5)	20.0(13.5)
30	7.5(3.0)	10.0(5.5)	12.0(7.5)	14.0(8.5)	16.0(10.0)	17.0(11.0)	18.5(12.0)	20.0(13.5)	21.0(14.0)
40	8.0(3.0)	11.0(6.0)	13.5(8.0)	16.0(9.5)	18.0(11.0)	19.5(12.5)	21.0(13.5)	22.5(15.0)	23.5(16.0)
50	8.5(3.5)	12.0(6.0)	15.0(8.5)	17.5(10.0)	19.5(12.0)	21.5(13.5)	23.0(15.0)	25.0(16.5)	26.0(17.5)
60	8.5(3.5)	12.5(6.5)	15.5(8.5)	18.0(10.5)	21.0(12.5)	23.5(14.0)	25.0(15.5)	27.0(17.0)	28.0(18.0)
80	9.0(3.5)	13.5(6.5)	17.0(9.0)	20.0(11.0)	23.0(13.5)	25.5(15.0)	28.0(17.0)	30.0(18.5)	31.5(20.0)
100	9.0(3.5)	14.0(6.5)	18.0(9.0)	21.5(11.5)	24.5(14.0)	27.5(16.0)	30.0(18.0)	32.5(19.5)	34.5(21.5)
120	9.0(3.5)	14.0(6.5)	18.5(9.0)	22.5(11.5)	25.5(14.0)	28.5(16.5)	31.5(18.5)	34.5(20.5)	37.0(22.5)
No limit	9.0(3.5)	14.5(6.5)	19.0(9.0)	23.0(12.0)	27.0(14.5)	30.0(17.0)	34.0(19.0)	36.0(21.0)	39.0(23.0)
<b>Enclosing rectangle 18 m high</b>									
3	2.0(1.0)	2.5(1.5)	3.5(2.0)	4.0(2.5)	5.0(2.5)	5.0(3.0)	6.0(3.5)	6.5(4.0)	6.5(4.0)
6	3.5(1.5)	4.5(2.5)	5.5(3.5)	6.5(4.0)	7.5(4.5)	8.0(5.0)	9.0(5.5)	9.5(6.0)	10.0(6.5)
9	4.5(2.0)	6.0(3.5)	7.0(4.5)	8.5(5.0)	9.5(6.0)	10.0(6.5)	11.0(7.0)	12.0(8.0)	12.5(8.5)
12	5.0(2.5)	7.0(4.0)	8.5(5.0)	10.0(6.0)	11.0(7.0)	12.0(7.5)	13.0(8.5)	14.0(9.0)	14.5(10.0)
15	6.0(2.5)	8.0(4.5)	9.5(6.0)	11.0(7.0)	12.5(8.0)	13.5(8.5)	14.5(9.5)	15.5(10.5)	16.5(11.0)
18	6.5(2.5)	8.5(5.0)	11.0(6.5)	12.0(7.5)	13.5(8.5)	14.5(9.5)	16.0(11.0)	17.0(11.5)	18.0(13.0)
21	7.0(3.0)	9.5(5.5)	11.5(7.0)	13.0(8.0)	14.5(9.5)	16.0(10.5)	17.0(11.5)	18.0(12.5)	19.5(13.0)
24	7.5(3.0)	10.0(5.5)	12.0(7.5)	14.0(8.5)	15.5(10.0)	16.5(11.0)	18.5(12.0)	19.5(13.0)	20.5(14.0)
27	8.0(3.5)	10.5(6.0)	12.5(8.0)	14.5(9.0)	16.5(10.5)	17.5(11.5)	19.5(12.5)	20.5(13.5)	21.5(14.5)
30	8.0(3.5)	11.0(6.5)	13.5(8.0)	15.5(9.5)	17.0(11.0)	18.5(12.0)	20.5(13.5)	21.5(14.5)	22.5(15.5)
40	9.0(4.0)	12.0(7.0)	15.0(9.0)	17.5(11.0)	19.5(12.0)	21.5(13.5)	23.5(15.0)	25.0(16.5)	26.0(17.5)
50	9.5(4.0)	13.0(7.0)	16.5(9.5)	19.0(11.5)	21.5(13.0)	23.5(15.0)	26.0(16.5)	27.5(18.0)	29.0(19.0)
60	10.0(4.0)	14.0(7.5)	17.5(10.0)	20.5(12.0)	23.0(14.0)	26.0(16.0)	27.5(17.5)	29.5(19.5)	31.0(20.5)
80	10.0(4.0)	15.0(7.5)	19.0(10.0)	22.5(13.0)	26.0(15.0)	28.5(17.0)	31.0(19.0)	33.5(21.0)	35.0(22.5)
100	10.0(4.0)	16.0(7.5)	20.5(10.0)	24.0(13.5)	28.0(16.0)	31.0(18.0)	33.5(20.5)	36.0(22.5)	38.5(24.0)
120	10.0(4.0)	16.5(7.5)	21.0(10.0)	25.5(14.0)	29.5(16.5)	32.5(19.0)	35.5(21.0)	39.0(23.5)	41.5(25.5)
No limit	10.0(4.0)	17.0(8.0)	22.0(10.0)	26.5(14.0)	30.5(17.0)	34.0(19.5)	37.0(22.0)	41.0(24.0)	43.5(26.5)

**Table 4.4 Permitted unprotected percentages in relation to enclosing rectangles (Method 3)**

Width of enclosing rectangle (m)	Distance from relevant boundary for unprotected percentage not exceeding								
	20%	30%	40%	50%	60%	70%	80%	90%	100%
	Minimum boundary distance (m) – figures in brackets are for Purpose Groups 1, 2, 3, 5 and 7(b)								
<b>Enclosing rectangle 21 m high</b>									
3	2.0(1.0)	3.0(1.5)	3.5(2.0)	4.5(2.5)	5.0(3.0)	5.5(3.0)	6.0(3.5)	6.5(4.0)	7.0(4.5)
6	3.5(1.5)	5.0(2.5)	6.0(3.5)	7.0(4.0)	8.0(5.0)	9.0(5.5)	9.5(6.0)	10.0(6.5)	10.5(7.0)
9	4.5(2.0)	6.5(3.5)	7.5(4.5)	9.0(5.5)	10.0(6.5)	11.0(7.0)	12.0(7.5)	13.0(8.5)	13.5(9.0)
12	5.5(2.5)	7.5(4.0)	9.0(5.5)	10.5(6.5)	12.0(7.5)	13.0(8.5)	14.0(9.0)	15.0(10.0)	16.0(10.5)
15	6.5(2.5)	8.5(5.0)	10.5(6.5)	12.0(7.5)	13.5(8.5)	14.5(9.5)	16.0(10.5)	16.5(11.0)	17.5(12.0)
18	7.0(3.0)	9.5(5.5)	11.5(7.0)	13.0(8.0)	14.5(9.5)	16.0(10.5)	17.0(11.5)	18.0(12.5)	19.5(13.0)
21	7.5(3.0)	10.0(6.0)	12.5(7.5)	14.0(9.0)	15.5(10.0)	17.0(11.0)	18.5(12.5)	20.0(13.5)	21.0(14.0)
24	8.0(3.5)	10.5(6.0)	13.0(8.0)	15.0(9.5)	16.5(10.5)	18.0(12.0)	20.0(13.0)	21.0(14.0)	22.0(15.0)
27	8.5(3.5)	11.5(6.5)	14.0(8.5)	16.0(10.0)	18.0(11.5)	19.0(13.0)	21.0(14.0)	22.5(15.0)	23.5(16.0)
30	9.0(4.0)	12.0(7.0)	14.5(9.0)	16.5(10.5)	18.5(12.0)	20.5(13.0)	22.0(14.5)	23.5(16.0)	25.0(16.5)
40	10.0(4.5)	13.5(7.5)	16.5(10.0)	19.0(12.0)	21.5(13.5)	23.0(15.0)	25.5(16.5)	27.0(18.0)	28.5(19.0)
50	11.0(4.5)	14.5(8.0)	18.0(11.0)	21.0(13.0)	23.5(14.5)	25.5(16.5)	28.0(18.0)	30.0(20.0)	31.5(21.0)
60	11.5(4.5)	15.5(8.5)	19.5(11.5)	22.5(13.5)	25.5(15.5)	28.0(17.5)	30.5(19.5)	32.5(21.0)	33.5(22.5)
80	12.0(4.5)	17.0(8.5)	21.0(12.0)	25.0(14.5)	28.5(17.0)	31.5(19.0)	34.0(21.0)	36.5(23.5)	38.5(25.0)
100	12.0(4.5)	18.0(9.0)	22.5(12.0)	27.0(15.5)	31.0(18.0)	34.5(20.5)	37.0(22.5)	40.0(25.0)	42.0(27.0)
120	12.0(4.5)	18.5(9.0)	23.5(12.0)	28.5(16.0)	32.5(18.5)	36.5(21.5)	39.5(23.5)	43.0(26.5)	45.5(28.5)
No limit	12.0(4.5)	19.0(9.0)	25.0(12.0)	29.5(16.0)	34.5(19.0)	38.0(22.0)	41.5(25.0)	45.5(26.5)	48.0(29.5)
<b>Enclosing rectangle 24 m high</b>									
3	2.0(1.0)	3.0(1.5)	3.5(2.0)	4.5(2.5)	5.0(3.0)	5.5(3.5)	6.0(3.5)	7.0(4.0)	7.5(4.5)
6	3.5(1.5)	5.0(2.5)	6.0(3.5)	7.0(4.5)	8.5(5.0)	9.5(5.5)	10.0(6.0)	10.5(7.0)	11.0(7.0)
9	5.0(2.0)	6.5(3.5)	8.0(5.0)	9.5(5.5)	11.0(6.5)	12.0(7.5)	13.0(8.0)	13.5(9.0)	14.5(9.5)
12	6.0(2.5)	8.0(4.5)	9.5(6.0)	11.5(7.0)	12.5(8.0)	14.0(8.5)	15.0(9.5)	16.0(10.5)	16.5(11.5)
15	6.5(3.0)	9.0(5.0)	11.0(6.5)	13.0(8.0)	14.5(9.0)	15.5(10.0)	17.0(11.0)	18.0(12.0)	19.0(13.0)
18	7.5(3.0)	10.0(5.5)	12.0(7.5)	14.0(8.5)	15.5(10.0)	16.5(11.0)	18.5(12.0)	19.5(13.0)	20.5(14.0)
21	8.0(3.5)	10.5(6.0)	13.0(8.0)	15.0(9.5)	16.5(10.5)	18.0(12.0)	20.0(13.0)	21.0(14.0)	22.0(15.0)
24	8.5(3.5)	11.5(6.5)	14.0(8.5)	16.0(10.0)	18.0(11.5)	19.5(12.5)	21.0(14.0)	22.5(15.0)	24.0(16.0)
27	9.0(4.0)	12.5(7.0)	15.0(9.0)	17.0(11.0)	19.0(12.5)	20.5(13.5)	22.5(15.0)	24.0(16.0)	25.5(17.0)
30	9.5(4.0)	13.0(7.5)	15.5(9.5)	18.0(11.5)	20.0(13.0)	21.5(14.0)	23.5(15.5)	25.0(17.0)	26.5(18.0)
40	11.0(4.5)	14.5(8.5)	18.0(11.0)	20.5(13.0)	23.0(14.5)	25.0(16.0)	27.5(18.0)	29.0(19.0)	30.5(20.5)
50	12.0(5.0)	16.0(9.0)	19.5(12.0)	22.5(14.0)	25.5(16.0)	27.5(17.5)	30.0(19.5)	32.0(21.0)	33.5(22.5)
60	12.5(5.0)	17.0(9.5)	21.0(12.5)	24.5(15.0)	27.5(17.0)	30.0(19.0)	32.5(21.0)	35.0(23.0)	36.5(24.5)
80	13.5(5.0)	18.5(10.0)	23.5(13.5)	27.5(16.5)	31.0(18.5)	34.5(21.0)	37.0(23.5)	39.5(25.5)	41.5(27.5)
100	13.5(5.0)	20.0(10.0)	25.0(13.5)	29.5(17.0)	33.5(20.0)	37.0(22.5)	40.0(25.0)	43.0(27.5)	45.5(29.5)
120	13.5(5.5)	20.5(10.0)	26.5(13.5)	31.0(17.5)	36.0(20.5)	39.5(23.5)	43.0(26.5)	46.5(29.0)	49.0(31.0)
No limit	13.5(5.5)	21.0(10.0)	27.5(13.5)	32.5(18.0)	37.5(21.0)	42.0(24.0)	45.5(27.5)	49.5(30.0)	52.0(32.5)

**Table 4.4 Permitted unprotected percentages in relation to enclosing rectangles (Method 3)**

Width of enclosing rectangle (m)	Distance from relevant boundary for unprotected percentage not exceeding								
	20%	30%	40%	50%	60%	70%	80%	90%	100%
	Minimum boundary distance (m) – figures in brackets are for Purpose Groups 1, 2, 3, 5 and 7(b)								
<b>Enclosing rectangle 27 m high</b>									
3	2.0(1.0)	3.0(1.5)	4.0(2.0)	4.5(2.5)	5.5(3.0)	6.0(3.5)	6.5(4.0)	7.0(4.0)	7.5(4.5)
6	3.5(1.5)	5.0(2.5)	6.5(3.5)	7.5(4.5)	8.5(5.0)	9.5(6.0)	10.5(6.5)	11.0(7.0)	12.0(7.5)
9	5.0(2.0)	7.0(3.5)	8.5(5.0)	10.0(6.0)	11.5(7.0)	12.5(7.5)	13.5(8.5)	14.5(9.5)	15.0(10.0)
12	6.0(2.5)	8.0(4.5)	10.5(6.0)	12.0(7.0)	13.5(8.0)	14.5(9.0)	16.0(10.5)	17.0(11.0)	17.5(12.0)
15	7.0(3.0)	9.5(5.5)	11.5(7.0)	13.5(8.5)	15.0(9.5)	16.5(10.5)	18.0(11.5)	19.0(12.5)	20.0(13.5)
18	8.0(3.5)	10.5(6.0)	12.5(8.0)	14.5(9.0)	16.5(10.5)	17.5(11.5)	19.5(12.5)	20.5(13.5)	21.5(14.5)
21	8.5(3.5)	11.5(6.5)	14.0(8.5)	16.0(10.0)	18.0(11.5)	19.0(13.0)	21.0(14.0)	22.5(15.0)	23.5(16.0)
24	9.0(3.5)	12.5(7.0)	15.0(9.0)	17.0(11.0)	19.0(12.5)	20.5(13.5)	22.5(15.0)	24.0(16.0)	25.5(17.0)
27	10.0(4.0)	13.0(7.5)	16.0(10.0)	18.0(11.5)	20.0(13.0)	22.0(14.0)	24.0(16.0)	25.5(17.0)	27.0(18.0)
30	10.0(4.0)	13.5(8.0)	17.0(10.0)	19.0(12.0)	21.0(13.5)	23.0(15.0)	25.0(17.0)	26.5(18.0)	28.0(19.0)
40	11.5(5.0)	15.5(9.0)	19.0(11.5)	22.0(14.0)	24.5(15.5)	26.5(17.5)	29.0(19.0)	30.5(20.5)	32.5(22.0)
50	12.5(5.5)	17.0(9.5)	21.0(12.5)	24.0(15.0)	27.0(17.0)	29.5(19.0)	32.0(21.0)	34.5(22.5)	36.0(24.0)
60	13.5(5.5)	18.5(10.5)	22.5(13.5)	26.5(16.0)	29.5(18.5)	32.0(20.5)	35.0(22.5)	37.0(24.5)	39.0(26.5)
80	14.5(6.0)	20.5(11.0)	25.0(14.5)	29.5(17.5)	33.0(20.5)	36.5(22.5)	39.5(25.0)	42.0(27.5)	44.0(29.5)
100	15.5(6.0)	21.5(11.0)	27.0(15.5)	32.0(19.0)	36.5(21.5)	40.5(24.5)	43.0(27.0)	46.5(30.0)	48.5(32.0)
120	15.5(6.0)	22.5(11.5)	28.5(15.5)	34.0(19.5)	39.0(22.5)	43.0(26.0)	46.5(28.5)	50.5(32.0)	53.0(34.0)
No limit	15.5(6.0)	23.5(11.5)	29.5(15.5)	35.0(20.0)	40.5(23.5)	44.5(27.0)	48.5(29.5)	52.0(33.0)	55.5(35.0)

## Method 4 (Aggregate notional area)

**4.16** This method can be used for a building or compartment of any purpose group. A building or compartment shall be so situated that the aggregate notional area of the unprotected areas in the side of the building or compartment does not exceed, in the case of –

**(a)** a building or compartment of Purpose Group 1, 2, 3, 5 or 7 (b) – 210 m<sup>2</sup>; or

**(b)** a building or compartment of any other purpose group – 90 m<sup>2</sup>,

when calculated from any vertical datum on its relevant boundary.

The aggregate notional area is the aggregate of the areas of unprotected area in the side of the building or compartment, each such unprotected area being multiplied by the Factor given in Table 4.5 relative to the distance the unprotected area is from the vertical datum.

A vertical datum is a vertical line of unlimited height at any point on the relevant boundary and the datum line is the line joining the vertical datum to the nearest point on the side of the building or compartment.

When calculating the aggregate notional area no account shall be taken of any unprotected area which is –

- (i)** screened from the vertical datum by any part of an external wall which is not an unprotected area;
- (ii)** outside a horizontal area centred on the vertical datum, having a radius of 50 m and extending 90° on either side of the datum line;
- (iii)** facing away from the vertical datum; or
- (iv)** making an angle of less than 10° with a line drawn from it to the vertical datum.

**Table 4.5 Multiplication factors for determining aggregate notional areas (Method 4)**

Distance of unprotected area from vertical datum (m)		Factor
Not less than	Less than	
1.0	1.2	80
1.2	1.8	40
1.8	2.7	20
2.7	4.3	10
4.3	6.0	4
6.0	8.5	2
8.5	12.0	1
12.0	18.5	0.5
18.5	27.5	0.25
27.5	50.0	0.1
50.0	No limit	0

## Canopies

**4.17** The high degree of ventilation and heat dissipation achieved by open sided canopies means that the space separation required by paragraph 4.11 may be onerous.

The provisions of paragraph 4.11 shall not apply to –

- (a)** a single storey, open sided canopy, constructed of non-combustible materials, which is not less than 1 m from its relevant boundaries; and
- (b)** a covered way, covered yard or a carport, which is open on two or more sides and is not more than 40 m<sup>2</sup> in area.

The provisions regarding roof coverings and roof separation distances shall apply (see paragraph 4.18 to 4.20).

---

## Roofs

### Roof covering designations

**4.18** The designation of a roof covering in respect of external fire exposure shall be determined by testing in accordance with BS 476: Part 3: 1958 and expressed by two letters in the range A to D. The notional designations of some generic roof coverings are given in Table 4.6. Where a thermoplastic material cannot be given a designation when tested to BS 476: Part 3: 1958 it may be used as a rooflight provided that it can be classified under paragraph 2.5 and is used in accordance with paragraph 4.20. Where unwired glass, not less than 4 mm thick, is used in a rooflight it shall be regarded as having an AA designation.

**Table 4.6 Notional designations of roof coverings**

**Part 1 – Pitched roofs covered with slates or tiles**

Covering material	Supporting structure	Designation
1 Natural slates	Timber rafters with or without	AA
2 Fibre reinforced cement sheets	underfelt, sarking, boarding,	
3 Clay tiles	wood wool slabs, compressed	
4 Concrete tiles	straw slabs, plywood, wood chipboard or fibre insulating board	
5 Bitumen felt strip slates Type 2E, with underlayer of bitumen felt Type 2B	Timber rafters and boarding, plywood, wood wool slabs, wood chipboard or fibre insulating board	BB
6 Strip slates of bitumen felt Class 1 or 2	Timber rafters and boarding, plywood, wood wool slabs, compressed straw slabs, wood chipboard or fibre insulating board	CC

**Notes –**

Any reference in this Table to bitumen felt of a specified type is a reference to bitumen felt as so designated in BS 747: 1977 (1986).

---

**Table 4.6 Notional designations of roof coverings**

**Part II – Pitched roofs covered with self-supporting sheets**

Details of covering		Supporting structure	Designation
Material	Construction		
1	Profiled sheets of – (i) galvanised steel; (ii) aluminium; (iii) fibre reinforced cement; or (iv) prepainted (coil coated) steel or aluminium with a PVC or PVF <sub>2</sub> coating	Single skin without underlay or with underlay of – (i) plasterboard; (ii) fibre insulating board; or (iii) wood wool slab	Structure of timber, steel or concrete     AA
2	Profiled sheets of – (i) galvanised steel; (ii) aluminium; (iii) fibre reinforced cement; or (iv) prepainted (coil coated) steel or aluminium with a PVC or PVF <sub>2</sub> coating	Double skin without interlayer or with interlayer of – (i) resin-bonded glass fibre; (ii) mineral wool slab; (iii) polystyrene; or (iv) polyurethane	Structure of timber, steel or concrete     AA

**Table 4.6 Notional designations of roof coverings**

**Part III – Pitched or flat roofs covered with fully supported material**

Details of covering		Designation
Covering material	Supporting structure	
1 Aluminium sheet	Timber joists and –	AA*
2 Copper sheet	(i) tongued and grooved boarding; or	
3 Zinc sheet	(ii) plain edged boarding	
4 Lead sheet		
5 Mastic asphalt	Steel or timber joists with deck of –	AA
6 Vitreous enamelled steel sheet	(i) wood wool slab;	
	(ii) compressed straw slab;	
	(iii) wood chipboard;	
7 Lead/tin alloy coated steel sheet	(iv) fibre insulating board; or	
	(v) 9.5 mm plywood	
8 Zinc/aluminium alloy alloy coated steel sheet	Concrete or clay pot slab (cast in situ or precast), or non-combustible deck of steel, aluminium or fibre reinforced cement (with or without insulation)	AA
9 Pre-painted (coil coated) steel sheet including liquid-applied PVC coatings		

**Notes –**

\* Lead sheet supported by timber joists and plain edge boarding shall be deemed to be of designation BA.

**Part IV – Flat roofs covered with bitumen felt**

A flat roof comprising a covering of bitumen felt shall (irrespective of the felt specification) be deemed to be of designation AA if the felt is laid on a deck constructed of any of the materials prescribed in the Table in Part V and has a surface finish of –

- (a) bitumen bedded stone chippings covering the whole surface to a depth of not less than 12.5 mm;
- (b) bitumen bedded tiles of a non-combustible material;
- (c) sand and cement screed; or
- (d) macadam

**Table 4.6 Notional designations of roof coverings**

**Part V – Pitched roofs covered with bitumen felt**

Details of felt		Details of deck						
Number of layers	Type of upper layer	Type of under-layer(s)	Deck of 6mm plywood 12.5mm wood or flax chipboard, 16mm (finished) T & G boarding or 19mm (finished) plain edged boarding	Deck of compressed straw slab	Deck of screeded wood wool slab	Profiled fibre reinforced cement or steel deck (single or double skin) without overlay or with overlay of fibre insulating board	Profiled aluminium (single or double skin) without overlay or with overlay of fibre insulating board	Concrete or clay pot slab (cast in situ of precast)
						AC	AC	
two or three layers built up in accordance with CP 144: Part 3: 1970	1 Type 1E	Type 1B (minimum mass 13kg/10 m <sup>2</sup> )	CC	AC	AC	AC	AC	AB
	2 Type 2E	Type 1B (minimum mass 13kg/10 m <sup>2</sup> )	BB	AB	AB	AB	AB	AB
	3 Type 2E	Type 2B	AB	AB	AB	AB	AB	AB
	4 Type 3E	Type 3B or 3G	BC	AC	AB	AB	AB	AB

**Notes –**

Any reference in this Table to bitumen felt of a specified type is a reference to bitumen felt as so designated in BS 747: 1977 (1986).

## Space separation roofs

**4.19** The minimum distance from any part of a roof, other than a plastic rooflight, to a relevant boundary (see paragraph 4.7) shall not be less than that given in Table 4.7 for the relevant designation of roof covering. The boundary formed by the compartment wall separating semi-detached dwellinghouses shall be disregarded for the purposes of this paragraph.

**Table 4.7 Limitations on roof coverings**

Designation of covering of roof or part of roof	Minimum distance from any point on relevant boundary			
	Less than 6m	Not less than 6m	Not less than 12 m	Not less than 20 m
AA, AB or AC	✓	✓	✓	✓
BA, BB or BC	X	✓	✓	✓
CA, CB or CC	X	✓ <sup>(1)</sup>	✓ <sup>(2)</sup>	✓
AD, BD or CD	X	✓ <sup>(1)</sup>	✓ <sup>(2)</sup>	✓ <sup>(2)</sup>
DA, DB, DC or DD	X	X	X	✓ <sup>(1)</sup>
Thatch or wood shingles, if performance under BS 476: Part 3: 1958 cannot be established	X	✓ <sup>(1)</sup>	✓ <sup>(2)</sup>	✓ <sup>(2)</sup>

### Notes –

✓ Acceptable.

X Not acceptable.

(1) (a) Not acceptable on any of the following buildings –

- (i) a dwellinghouse in a terrace of three or more dwellinghouses;
- (ii) a building of Purpose Group 6 or 7 of any size; and
- (iii) a building of any other purpose group greater than 1500 m<sup>3</sup>

(b) Acceptable on other buildings only where that part of the roof is –

- (i) not more than 3 m<sup>2</sup> in area;
- (ii) not less than 1.5 m from any similar part; and
- (iii) the roof covering between any such parts is a material of limited combustibility.

(2) Not acceptable on any of the buildings listed under Note (1)(a) above.

**4.20** Where a roof incorporates a plastic rooflight, which is not designated AA, AB, AC, BA, BB or BC, the minimum distance from that rooflight to a relevant boundary shall not be less than that given in Table 4.8 for the appropriate classification of the rooflight and the space over which it is located.

For the purposes of this paragraph and Table 4.8 a rigid thermoplastic rooflight, made from polycarbonate or unplasticised PVC, which achieves a Class 1 classification for surface spread of flame (see paragraph 2.4) shall be regarded as having an AA designation.

**Table 4.8 Plastic rooflights – Limitations on use and boundary distance**

Minimum classification on lower surface <sup>(1)</sup>	Space which rooflight can serve	Minimum distance (m) from any point on relevant boundary to rooflight with an external surface classification of		
		TP(a)	AD, BD, CA, CB, CC, CD or TP(b)	DA, DB, DC or DD
1 TP(a) rigid	Any space except a protected stairway	6 <sup>(2)</sup>	6 <sup>(3)</sup>	20
2 Class 3 or TP(b)	(a) Balcony, verandah, carport, covered way or loading bay which has at least one longer side wholly or permanently open	6	6	20
	(b) Detached swimming pool			
	(c) Conservatory, garage or outbuilding, with a maximum floor area of 40 m <sup>2</sup>			
	(d) Circulation space <sup>(4)</sup> (except a protected stairway)	6 <sup>(3)</sup>	6 <sup>(3)</sup>	20 <sup>(3)</sup>
	(e) Room <sup>(4)</sup>			

**Notes –**

- (1) As required by paragraph 2.12.
- (2) No limit in the case of any space described in items 2(a), (b) and (c).
- (3) The rooflight shall also comply with Diagram 4.5.
- (4) Single skin rooflight only, in the case of non-thermoplastic materials.

**Diagram 4.5 Limitation on areas and spacing of certain thermoplastic rooflights**

see Table 4.8 note (3)

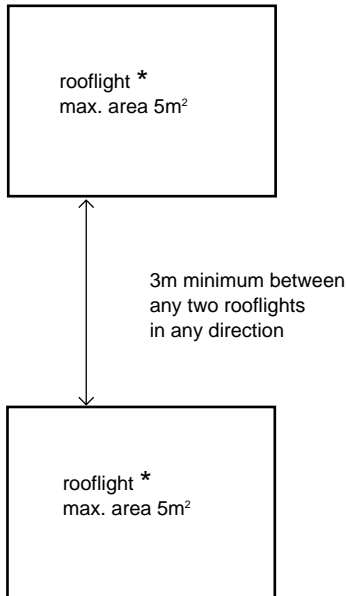

**Note –**

\* Or group of rooflights amounting to not more than 5m².

(1) Surrounding roof covering to be a material of limited combustibility for at least 3m distance.

# Section 5 – Facilities and access for the Fire Brigade

**5.1** This section contains provisions to ensure that there is –

- (a) sufficient means of access to and within a building for firefighting personnel to effect rescue and fight fire;
- (b) sufficient facilities to assist firefighters in their tasks;
- (c) adequate means of venting smoke from a fire in a basement; and
- (d) adequate external access to enable firefighting appliances to be brought near to a building for effective use.

## Firefighting shafts

**5.2** A shopping complex shall be provided with firefighting shafts in accordance with the recommendations of BS 5588: Part 10: 1991 Section 3. Any other building shall be provided with a firefighting shaft or shafts, to serve all storeys, where it has –

- (a) a storey more than 20 m above fire brigade access level;
- (b) a storey (other than one which is an open sided car park) 600 m<sup>2</sup> or more in area at a height of 7.5 m or more above fire brigade access level;
- (c) a storey more than 10 m below fire brigade access level; or
- (d) two or more basement storeys any of which is 900 m<sup>2</sup> or more in area.

However, a firefighting shaft provided under (a) or (b) need not serve a basement storey unless (c) or (d) applies and similarly a firefighting shaft provided under (c) or (d) need not serve an upper storey unless (a) or (b) applies.

Diagram 5.1 illustrates the provisions of this paragraph.

**5.3** Where a building is to be provided with firefighting shafts the minimum number (subject to paragraph 5.4) shall be –

- (a) where a building is fitted throughout with an automatic sprinkler system complying with BS 5306: Part 2: 1990 – as given in Table 5.1 for the appropriate floor area; or

- (b) where a building is not fitted throughout with such a sprinkler system – at least one for every 900 m<sup>2</sup>, (or part thereof) of floor area of the largest storey given in paragraph 5.2 (a) to (d) as appropriate.

**Table 5.1 Minimum number of firefighting shafts in a building fitted with a sprinkler system**

Floor area of the largest storey (m <sup>2</sup> )	Minimum number of firefighting shafts
Less than 900	1
900 to 2000	2
Over 2000	2 plus 1 for every 1500m <sup>2</sup> or part thereof of floor area

**5.4** Firefighting shafts shall be located so that every part of every storey (other than fire brigade access level) is not more than 60 m from the entrance to a firefighting shaft, measured on a route suitable for laying a fire hose. Where the internal layout is unknown every part of every such storey shall be not more than 40 m, in a direct line, from the entrance to a firefighting shaft.

## Diagram 5.1 Provision of firefighting shafts

see para 5.2

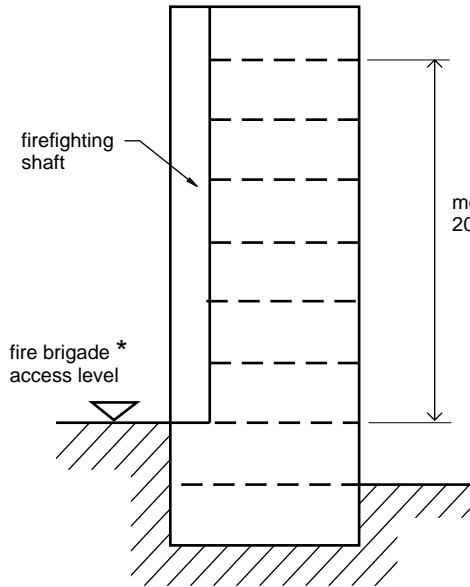

Case (a)

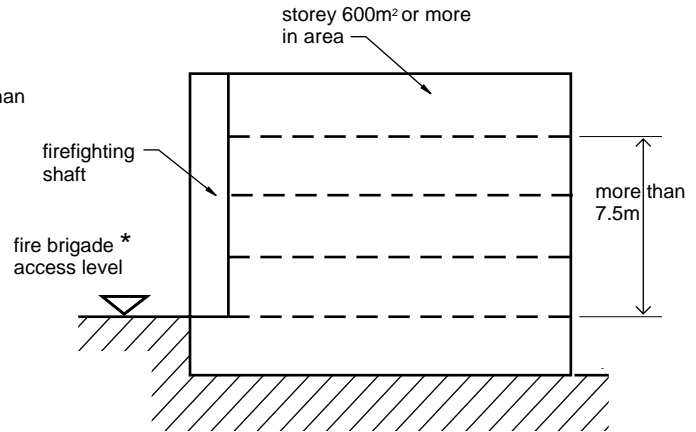

Case (b)

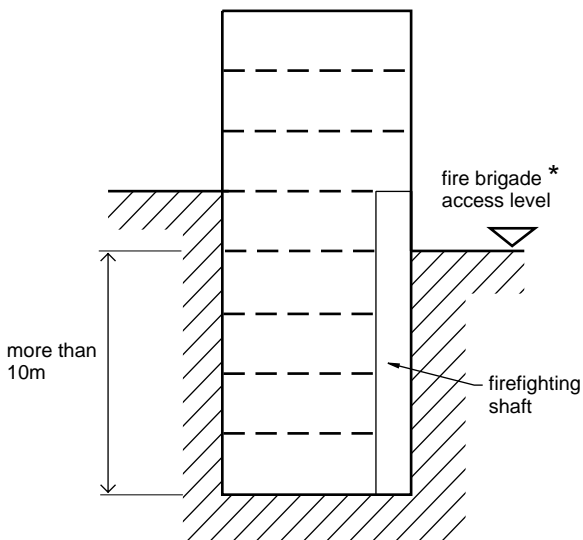

Case (c)

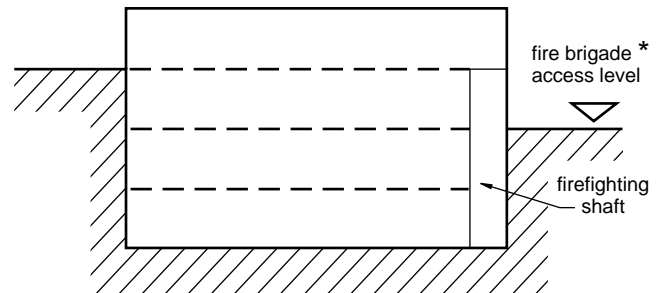

two or more basement storeys any of which 900m<sup>2</sup> or more in area

Case (d)

### Note

\* When measuring the height to an upper storey the highest level at which the Fire Brigade can gain access shall be used and similarly when measuring the depth of a basement storey the lowest level shall be used.

(1) In cases (a) and (c) the firefighting shaft shall include a firefighting lift.

---

**5.5** Firefighting shafts shall be designed and constructed in accordance with the recommendations of BS 5588: Part 5: 1991 Sections 2 and 4.

Where a building falls within paragraph 5.2 (a) or (c) all firefighting shafts shall have a firefighting lift complying with the recommendations of BS 5588: Part 5: 1991 Section 3.

### **Fire mains**

**5.6** A firefighting shaft shall be provided with –

- (a) a wet fire main where it has a storey more than 60 m above fire brigade access level; or
- (b) a wet or a dry fire main in any other case.

**5.7** Fire mains shall be located in the firefighting lobbies of firefighting shafts and shall have an outlet connection and valve at every level other than at fire brigade access level.

**5.8** The design and construction of a fire main shall be in accordance with the relevant recommendations of BS 5306: Part 1: 1976 (1988).

### **Venting of heat and smoke from basements**

**5.9** Venting facilities, connected directly to the external air, shall be provided from every basement storey other than –

- (a) a basement in a building of Purpose Group 1(b) or (c);
- (b) a basement storey which –
  - (i) has a floor area not more than 200 m<sup>2</sup>; or
  - (ii) has a floor not more than 3 m below the lowest adjacent ground level;
- (c) a basement storey used for car parking and ventilated in accordance with paragraph 3.42; and
- (d) a basement storey or that part of a basement storey used as a strong room.

### **Natural venting**

**5.10** A basement storey may be ventilated by smoke outlets which shall –

- (a) be sited at ceiling level within the space they serve;

- (b) have an aggregate free area of not less than 2.5% of the floor area of the space they serve;

- (c) be distributed as evenly as possible around the perimeter of the building;

- (d) be located so that they do not adversely affect any escape route from the building; and

- (e) have a sign stating “smoke outlet from basement” fixed adjacent to each external outlet point.

The smoke outlets from a place of special fire risk shall be separate from the smoke outlets from other areas.

**5.11** Smoke outlets may discharge by means of windows, stall-board risers or pavement lights which can be opened or knocked out provided such covers are readily accessible to the Fire Brigade.

Shafts enclosing smoke outlets shall be of smoke tight non-combustible construction and have the same period of fire resistance as that for elements of structure in the basement storey served.

Shafts from different parts of the same basement storey, or from different basement storeys, shall be separated by smoke tight non-combustible fire-resisting construction.

### **Mechanical venting**

**5.12** A basement may be ventilated by a mechanical air extraction system provided –

- (a) the basement has a sprinkler system complying with BS 5306: Part 2: 1990; and
- (b) the air extraction system has a capacity not less than 10 air changes per hour and is capable of operating at a temperature of 400°C for not less than 60 minutes.

The air extraction system shall come into operation automatically on the activation of either –

- (i) the sprinkler system; or
- (ii) the fire detection and alarm system in the basement where this system complies with BS 5839: Part 1: 1988, of at least L3 standard.

## Vehicle access

**5.13** The provisions for vehicle access are related to whether or not the building has a fire main or mains and, where it does not, to the size and height of the building. Where a building –

- (a) does not have a fire main and is –
- (i) less than 2000 m<sup>2</sup> in area and the height to the top storey is less than 9 m – access for a pump appliance shall be provided to within 45 m of the building; or  
[Note – the Building Regulations cannot impose requirements for work to be done beyond the boundary of the premises.]
  - (ii) other than as described in (i) – access shall be provided in accordance with Table 5.2;
- (b) has dry fire mains – access for a pumping appliance shall be provided to within 18 m, and within sight of, each fire main inlet connection point; and
- (c) has wet fire mains – access for a pumping appliance shall be provided to within 18 m, and within sight of the emergency replenishment inlet of the tank serving each fire main.

In every elevation to which the fire brigade access is provided there shall be a door, not less than 750 mm wide, giving access to the interior of the building. Where fire mains are provided a door shall give access to each fire main.

## Vehicle access routes and vehicular hardstandings areas

**5.14** A vehicle access route and vehicular hardstanding area shall be designed and constructed to the standards given in Table 5.3 and, in the case of those for high reach appliances, the dimensions shown in Diagram 5.2.

Where the height of the top storey of a building is more than 9 m above the level of the adjoining ground the vehicle access route and the vehicular hardstanding area shall be suitable for a high reach appliance. For lower buildings a vehicle access route shall be suitable for a pump appliance.

**5.15** Turning facilities shall be provided in a dead-end vehicle access route which is more than 20 m in length.

Vehicular hardstanding areas shall be as level as possible and shall not exceed a gradient of 1 in 12.

**Table 5.2 Fire brigade vehicle access to buildings not fitted with fire mains**

Area of building (m <sup>2</sup> )	Height to top storey <sup>(1)</sup> (m)	Provide vehicle access to	Type of appliance
Up to 2000	Up to 9 Over 9	See paragraph 5.13(a) 15% of perimeter <sup>(2)</sup>	Pump High reach
2000-8000	Up to 9 Over 9	15% of perimeter <sup>(2)</sup> 50% of perimeter <sup>(2)</sup>	Pump High reach
8000-16000	Up to 9 Over 9	50% of perimeter <sup>(2)</sup> 50% of perimeter <sup>(2)</sup>	Pump High reach
16000-24000	Up to 9 Over 9	75% of perimeter <sup>(2)</sup> 75% of perimeter <sup>(2)</sup>	Pump High reach
Over 24000	Up to 9 Over 9	100% of perimeter <sup>(2)</sup> 100% of perimeter <sup>(2)</sup>	Pump High reach

### Notes –

- (1) For Purpose Group 7(a) buildings the height shall be measured to the mean roof level.
- (2) The perimeter is the aggregate plan perimeter found by vertical projection onto a horizontal ground plane excluding walls separating buildings.

**Table 5.3 Vehicle access routes**

Appliance type	Minimum width of road between kerbs (m)	Minimum width of gateways (m)	Minimum turning circle between kerbs (m)	Minimum turning circle between walls (m)	Minimum clearance height (m)	Minimum carrying capacity (tonnes)
Pump	3.7	3.1	16.8	19.2	3.7	12.5
High reach	3.7	3.1	26.0	29.0	4.0	17.0

**Diagram 5.2 Relationship between a building and a vehicle access route or a vehicular hardstanding area for a high reach appliance**

see para 5.14

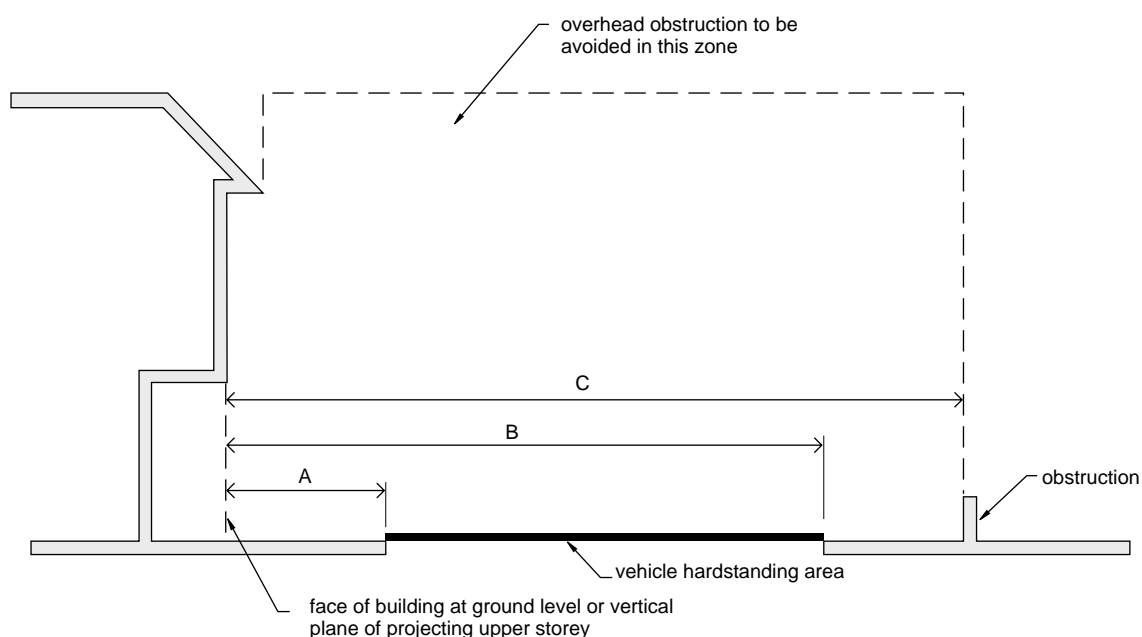

**Type of appliance**

**Dimensions**

- A maximum distance\* to near edge of vehicle hardstanding area
- B minimum distance to farthest edge of vehicle hardstanding area
- C minimum width of unobstructed space

	Hydraulic platform (m)	Turntable ladder (m)
A	2.0	4.9
B	7.5	10.0
C	9.7	10.0

**Note**

\* The hardstanding may extend closer to the building but any such extension shall not be considered as a vehicle hardstanding area.

## Section 6 – Common provisions

**6.1** The provisions of this Section shall apply when using Sections 1 to 5 of this Technical Booklet.

### **Purpose groups**

**6.2** As many of the provisions in this Technical Booklet are related to the use of a building or compartment it is necessary to classify each building and compartment, according to its use, into a purpose group.

A building may have a single use or it may have many uses. Sub-paragraphs (b) and (c) describe the circumstances where it is appropriate to treat a different use as a purpose group in its own right. (Note that the provisions of paragraph 3.11 require compartmentation between different purpose groups.)

Every building and compartment shall be classified according to its use, or intended use, into the most appropriate of those purpose groups given in Table 6.1 and –

**(a)** where the use of a building or compartment will vary from time to time, it shall be classified as the purpose group to which the more or most onerous provisions in Section 3 apply;

**(b)** where a building or compartment has one or more uses which are not ancillary to the main use of that building or compartment, each portion given over to a separate use shall be classified separately; and

**(c)** where the building or compartment has one or more uses which are ancillary to the main use of that building or compartment, each portion given over to an ancillary use shall be classified separately when –

(i) it is a flat or maisonette;

(ii) in a Purpose Group 4 building or compartment – it is storage occupying more than one third of the total floor area of the building or compartment; or

(iii) in a building of any other purpose group – it is a use [other than in (i) and (ii)] occupying more than one fifth of the total floor area of the building or compartment.

**Table 6.1 Classification of purpose groups**

Title	Group	Purpose for which the building or compartment of a building is intended to be used
Residential** (Dwellings)	1(a)	Flat or maisonette
	1(b)	Dwellinghouse which contains a habitable storey with a floor level which is more than 4.5 m above ground level
	1(c)	Dwellinghouse which does not contain a habitable storey with a floor level which is more than 4.5 m above ground level
Residential (Institutional)	2(a)	Hospital, nursing home, home for old people or for children, school or other similar establishment used as living accommodation or for the treatment, care or maintenance of people suffering from illness or mental or physical disability or handicap, place of detention, where such people sleep on the premises
(Other)	2(b)	Hotel, boarding house, residential college, hall of residence, hostel, house in multiple occupation, and any other residential purpose not described above
Office	3	Offices or premises used for the purpose of administration, clerical work (including writing, book keeping, sorting papers, filing, typing, duplicating, machine calculating, drawing and the editorial preparation of matter for publication, police and fire service work), handling money (including banking and building society work), and communications (including postal, telegraph and radio communications) or radio, television, film, audio or video recording, or performance (not open to the public) and their control
Shop and Commercial	4	Shops or premises used for a retail trade or business (including the sale to members of the public of food or drink for immediate consumption and retail by auction, self-selection and over-the-counter wholesale trading, the business of lending books or periodicals for gain and the business of a barber or hairdresser) and premises to which the public is invited to deliver or to collect goods in connection with their hire, repair or other treatment, or (except in the case of repair of motor vehicles) where they themselves may carry out such repairs or other treatments
Assembly and Recreation	5	Place of assembly, entertainment or recreation, including bingo halls, broadcasting, recording and film studios open to the public, casinos, dance halls, entertainment-, conference-, exhibition- and leisure- centres, funfairs and amusement arcades, museums and art galleries, non-residential clubs, theatres, cinemas and concert halls, educational establishments, dancing schools, gymnasia, swimming pool buildings, riding schools, skating rinks, sports pavilions, sports stadia, law courts, churches and other buildings for worship, crematoria, libraries open to the public, non-residential day centres, clinics, health centres and surgeries, passenger stations and termini for air, rail, road or sea travel, public toilets, zoos and menageries
Industrial	6	Factories and other premises used for manufacturing, altering, repairing, cleaning, washing, breaking-up, adapting or processing any article, generating power, or slaughtering livestock
Storage and other non-residential <sup>+</sup>	7(a)	Place for the storage or deposit of goods or materials [other than described under 7(b)] and any building not within any of the Purpose Groups 1 to 6
	7(b)	Car parks designed to admit and accommodate only cars, motorcycles and passenger or light goods vehicles weighing no more than 2500 kg gross

\* Purpose Group 1 includes –

- (a) any surgeries, consulting rooms, offices or similar accommodation not more than 50 m<sup>2</sup> in total floor area, forming part of a dwelling and used by an occupant of the dwelling in a professional or business capacity; and
- (b) an attached garage not more than 40 m<sup>2</sup> in floor area.

+ A detached garage or open carport not more than 40 m<sup>2</sup> in floor area is included in Purpose Group 1(c); as is a detached building which consists of a garage and open carport where neither the garage nor open carport exceeds 40m<sup>2</sup> in area.

## Rules for measurement

**6.3 (a)** The area of a roof, rooflight or floor shall be measured as shown in Diagram 6.1.

**(b)** The cubic capacity of a building, separated part or compartment shall be measured (as shown in Diagram 6.2) from –

- (i) the upper surface of the lowest floor;
- (ii) the under surface of roof or ceiling surface as appropriate; and
- (iii) the inner surfaces of the enclosing walls or, where there is no enclosing wall, the outermost edge of the floor.

The volume of internal floors, walls and partitions shall be included for calculation purposes.

**(c)** The number of storeys in a building or a separated part of a building shall be counted as shown in Diagram 6.3, and shall exclude basement storeys.

In a building of Purpose Group 5 a gallery (other than a loading gallery, fly gallery, stage grid, lighting bridge, or any gallery used for similar purposes, or provided for the purposes of maintenance or repair) shall be counted as a storey. In a building of any other purpose group a gallery shall not be counted as a storey.

**(d)** The height to a building shall be measured as shown in Diagram 6.4.

**(e)** The height to a storey (other than when measuring for firefighting shaft purposes) shall be measured from the lowest ground level adjacent to the building to the upper surface of the floor in that storey, as shown in Diagram 6.5.

**(f)** The depth of a basement (other than when measuring for firefighting shaft purposes) shall be measured from the highest ground level adjacent to the building to the upper surface of the floor of the lowest basement storey as shown in Diagram 6.5.

### Diagram 6.1 Areas

see para 6.3(a)

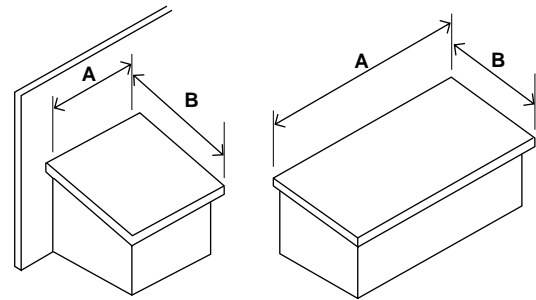

(i) Lean-to roof

(ii) Flat or monopitch roof

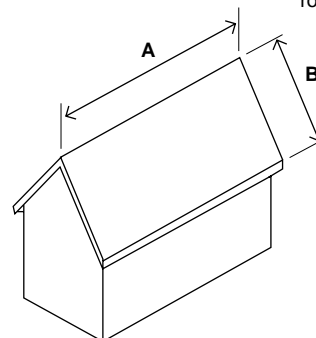

(iii) Double pitch roof

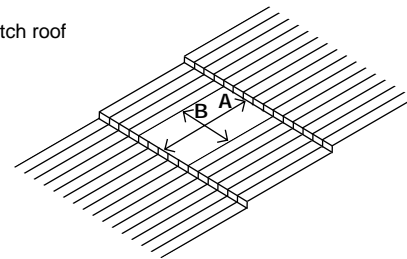

(iv) Rooflight

**(a) Surface area – roofs and rooflights – in each case measure the visible area**

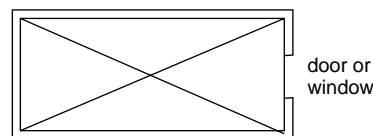

(i) Building or room

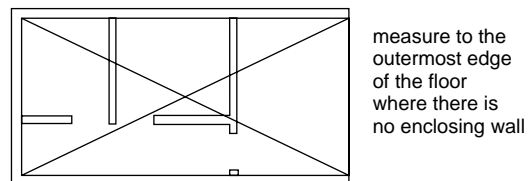

(ii) Storey, separated part or compartment

**(b) Floor area – in each case measure to the internal surface of enclosing walls and include internal walls and partitions**

## Diagram 6.2 Cubic capacity

see para 6.3(b)

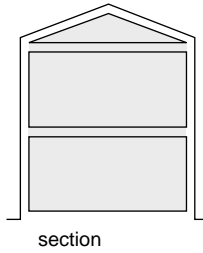

(a) Building

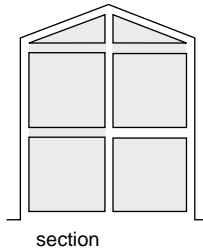

(a) Separated part or compartment of a building

## Diagram 6.3 Number of storeys

see para 6.3(c)

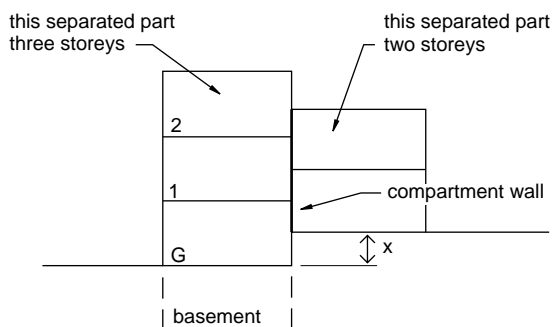
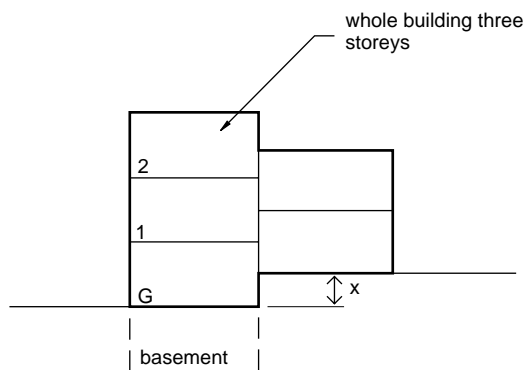

**Note**

- (1) Count at the position which gives the greatest number of storeys.
- (2) Where X exceeds 1.2m the building or separated part is considered to have two basement storeys and therefore be a two storey building.

## Diagram 6.4 Height of a building

see para 6.3(d)

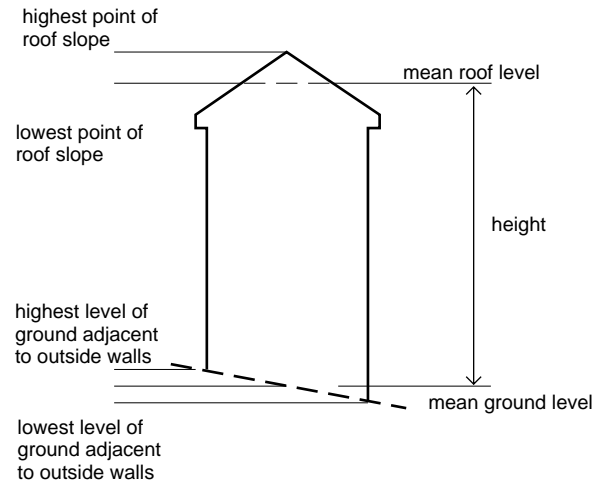

(a) Double pitch roof

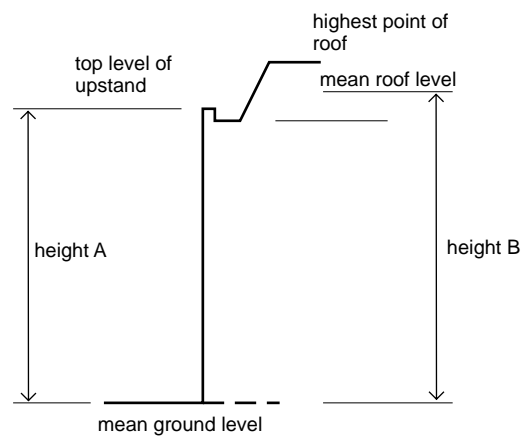

use height A or B whichever is greater

(b) Mansard type roof

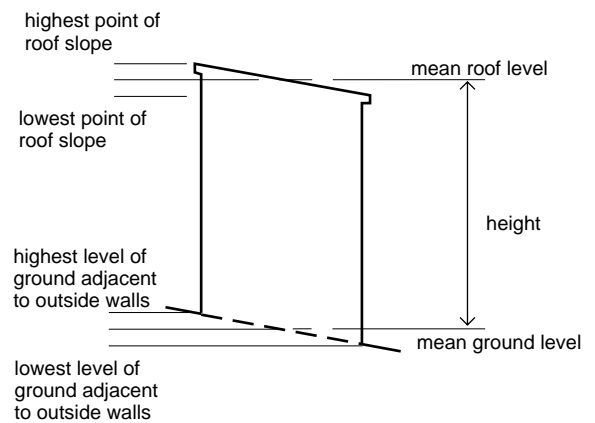

(c) Flat or monopitch roof

## Diagram 6.5 Height to a storey and depth of a basement

see para 6.3(e) and 6.3(f)

height to top storey excludes  
roof top plant areas

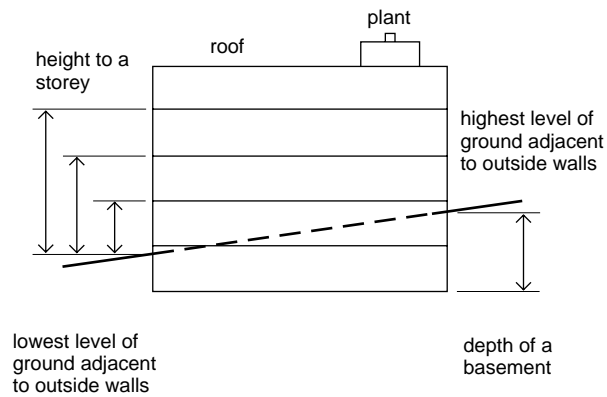

(c) a material of density not less than  $300 \text{ kg/m}^3$  which, when tested in accordance with BS 476: Part 11: 1982 (1988), does not flame or increase the temperature on the furnace thermocouple by more than  $20^\circ\text{C}$ ; or

(d) in the case of insulation referred to in Table 3.3 and paragraph 4.4 - a material of density less than  $300 \text{ kg/m}^3$  which, when tested in accordance with BS 476: Part 11: 1982 (1988) does not flame for more than 10 seconds and the rise in temperature is not more than  $35^\circ\text{C}$  on the centre (specimen) thermocouple and not more than  $25^\circ\text{C}$  on the furnace thermocouple.

## Non-combustible materials

6.4 A non-combustible material is –

(a) a material classified as non-combustible when tested in accordance with BS 476: Part 4: 1970 (1984);

(b) a material which when tested in accordance with BS 476: Part 11: 1982 (1988) does not flame and does not cause a rise in temperature on either the centre (specimen) thermocouple or the furnace thermocouple;

(c) a material which is either totally inorganic or does not contain more than 1% by weight or volume, of organic material; or

(d) concrete bricks or blocks complying with BS 6073: Part 1: 1981.

## Materials of limited combustibility

6.5 A material of limited combustibility is –

(a) a material which can be classified as non-combustible;

(b) a material with a non-combustible core not less than 8 mm thick having combustible facings (on one or both sides) not more than 0.5 mm thick;

---

## Definitions

**6.6** In this Technical Booklet the following definitions apply –

**Access room** – a room that forms the only escape route from an inner room.

**Accommodation stairway** – a stairway, additional to that or those required for escape purposes, provided for the convenience of occupants.

**Alternative escape routes** – escape routes sufficiently separated by either direction and space, or by fire-resisting construction, to ensure that one is still available should the other be affected by fire.

**Alternative exit** – one of two or more exits, each of which is separate from the other.

**Appliance ventilation duct** – a duct provided to convey combustion air to a gas appliance.

**Atrium** – a vertical space within a building, other than a shaft used solely for stairs, escalators, lifts or services, openly connecting three or more storeys and enclosed at the top by a floor or roof.

**Automatic fire detection and alarm system** – a system incorporating smoke detectors, sounders, control equipment, protected wiring and a back-up power supply which is capable of automatically detecting smoke and thereupon giving an audible alarm.

**Automatic release mechanism** – a device which will allow a door held open by it to close automatically in the event of each or any one of the following –

- (a) detection of smoke by automatic apparatus suitable in nature, quality and location;
- (b) operation of a hand operated switch fitted in a suitable position;
- (c) failure of electricity supply to the device, apparatus or switch; and
- (d) operation of the fire alarm system where fitted.

**Automatic self-closing device** – does not include rising butt hinges unless the door is –

- (a) to (or within) a dwelling;
- (b) between a dwellinghouse and its garage; or
- (c) in a cavity barrier.

**Basement storey** – a storey with a floor which at some point is more than 1.2 m below the highest level of ground adjacent to the outside walls.

**Cavity barrier** – a construction provided to close a concealed space against penetration of smoke or flame, or provided to restrict the movement of smoke or flame within such a space.

**Ceiling** – a part of a building which encloses and is exposed overhead in a room, protected shaft or circulation space. (The soffit of a rooflight, but not the frame is included as part of the ceiling surface. An upstand below a rooflight shall be considered as wall.)

**Circulation space** – a space (including a protected stairway) mainly used as a means of access between a room and an exit from the building or compartment.

**Class O** – a product performance classification for wall and ceiling linings. The relevant test criteria are set out in paragraph 2.4.

**Compartment** – a building or part of a building, comprising one or more rooms, spaces or storeys, constructed to prevent the spread of fire to or from another part of the same building, or an adjoining building. A roof space above the top storey of a compartment is included in that compartment.

**Compartment floor** – a fire-resisting floor used in the separation of one compartment from another.

**Compartment wall** – a fire-resisting wall used in the separation of one compartment from another.

**Concealed space or cavity** – a space enclosed by elements of a building (including a suspended ceiling) or contained within an element, but not a room, cupboard, circulation space, protected shaft or space within a flue, chute, duct, pipe or conduit.

**Dead-end** – area from which escape is possible in one direction only.

---

**Direct distance** – the shortest distance from any point within the floor area to the nearest storey exit, measured within the external enclosures of the building, ignoring walls, partitions and fittings, other than the enclosing walls/partitions to protected stairways.

**Element of structure** –

- (a) a member forming part of the structural frame of a building or any other beam or column;
- (b) a loadbearing wall or loadbearing part of a wall;
- (c) a floor;
- (d) a gallery;
- (e) an external wall; and
- (f) a compartment wall (including a wall common to two or more buildings).

(However, see paragraph 3.6 for exclusions from the provisions for elements of structure.)

**Emergency lighting** – lighting provided for use when the electricity supply to the normal lighting fails.

**Escape lighting** – that part of the emergency lighting which is provided to ensure that the escape route is illuminated at all material times.

**Escape route** – route forming that part of the means of escape from any point in a building to a final exit.

**Evacuation lift** – a lift that may be used for the evacuation of disabled people in the event of a fire.

**External wall** (or side of a building) – includes a part of a roof pitched at an angle of more than 70° to the horizontal, if that part of the roof adjoins a space within the building to which persons have access (but not access only for repair or maintenance).

**Final exit** – the termination of an escape route from a building giving direct access to a street, passageway, walkway or open space, and sited to ensure the rapid dispersal of people from the vicinity of a building so that they are no longer in danger from fire or smoke or both.

**Fire door** – a door or shutter, provided for the passage of people, air or objects, which together with its frame and furniture as installed in a building, is intended (when closed) to resist the passage of fire or gaseous products of combustion or both, and is capable of meeting specified performance criteria to those ends. (it may have one or more leaves, and the term includes a cover or other form of protection to an opening in a fire-resisting wall or floor, or in a structure surrounding a protected shaft.)

**Fire-resisting** (fire resistance) – the ability of a component or construction of a building to satisfy for a stated period of time, some or all of the appropriate criteria specified in the relevant Part of BS 476.

**Fire stop** – a seal provided to close an imperfection of fit or design tolerance between elements or components, to restrict or prevent the passage of fire and smoke.

**Firefighting lift** – a lift designed to have additional protection, with controls that enable it to be used under the direct control of the Fire Brigade when fighting a fire.

**Firefighting lobby** – a protected lobby for providing access from a firefighting stairway to the accommodation area and to any associated firefighting lift.

**Firefighting shaft** – a protected enclosure containing a firefighting stairway, firefighting lobbies and, if provided, a firefighting lift together with its machinery.

**Firefighting stairway** – a protected stairway communicating with the accommodation area only through a firefighting lobby.

**Gallery** – a floor, including a raised storage area, which is less than one-half of the floor area of the space into which it projects and is open both above and below to that space.

**Inner room** – a room from which escape is possible only by passing through another room (access room).

**Materials of limited combustibility** – materials which comply with paragraph 6.5.

---

**Measurement** –

(a) the rules for measuring area, cubic capacity, number of storeys, height of a building and height to a storey are given in paragraph 6.3; and

(b) the methods for measuring occupant capacity, travel distance, and the width of a doorway, escape route and stairway are given in Section 1.

**Non-combustible material** – a material which complies with paragraph 6.4.

**Notional boundary** – a boundary presumed to exist between buildings on the same site (see paragraph 4.7).

**Open spatial planning** – the internal arrangement of a building in which more than one storey or level is contained in one undivided volume, e.g. split-level floors. For the purposes of this Technical Booklet there is a distinction between open spatial planning and an atrium space.

**Perimeter** (of building) – the maximum aggregate plan perimeter excluding any wall separating buildings, found by vertical projection onto a horizontal plane.

**Pipe** – (for the purposes of Section 3) includes pipe fittings and accessories; and excludes a flue pipe and a pipe used for ventilating purposes (other than a ventilating pipe for an above ground drainage system).

**Places of special fire risk** – oil-filled transformer and switchgear rooms, boiler rooms, storage space for fuel or other highly flammable substances and rooms housing a fixed internal combustion engine.

**Platform floor** (access or raised floor) – a floor supported by a structural floor, but with an intervening concealed space which is intended to house services.

**Pressurization** – a method of protecting escape routes against the ingress of smoke by maintaining the air within them at pressures higher than those in adjacent parts of the building.

**Protected circuit** – an electrical circuit protected against fire.

**Protected corridor or lobby** – a corridor or lobby which is adequately protected from fire in adjoining accommodation by fire-resisting construction.

**Protected entrance hall or landing** – a circulation area consisting of a hall or space within a dwelling, enclosed with fire-resisting construction (other than any part which is an external wall or building).

**Protected shaft** – a shaft which enables people, air or objects to pass from one compartment to another, and which is enclosed with fire-resisting construction.

**Protected stairway** – a stairway discharging through a final exit to a place of safety (including any exit passageway between the foot of the stair and the final exit) that is adequately enclosed with fire-resisting construction.

**Purpose group** – a classification of buildings or compartments according to the purpose to which they are intended to be put (see paragraph 6.2).

**Relevant boundary** – the boundary which the side of the building faces, (and/or coincides with) and which is parallel, or at an angle of not more than 80°, to the side of the building. A notional boundary can be a relevant boundary.

**Rooflight** – a domelight, lantern light, skylight, ridge light, glazed barrel vault or other element intended to admit daylight through a roof.

**Room** – (for the purposes of Section 2) an enclosed space within a building that is not used solely as a circulation space. (The term includes not only conventional rooms, but also cupboards that are not fittings, and large spaces such as warehouses, and auditoria. The term does not include voids such as ducts, ceiling voids and roof spaces.)

**Self-contained smoke alarm** – an electrical mains powered device (with or without a back-up power source) containing within a single housing all the components necessary for detecting smoke and thereupon giving an audible alarm.

---

**Separated part** (of a building) – a form of compartmentation in which a part of a building is separated from another part of the same building by a compartment wall. The wall runs the full height of the part, and is in one vertical plane.

**Single storey building** – a building consisting only of a ground storey and any basement storeys. (A separated part which consists of a ground storey only, with a roof to which access is only provided for repair or maintenance, may be treated as a single storey building.)

**Storey exit** – a final exit, or a doorway giving direct access into a protected stairway, firefighting lobby, or external escape route. (In some circumstances a door in a compartment wall may be considered as a storey exit, e.g. in a hospital designed for progressive horizontal evacuation.)

**Storey** – includes –

(a) in a building of Purpose Group 5 – a gallery [other than the exceptions given in paragraph 6.3(c)]; and

(b) in a building of any purpose group – a roof which is accessible unless it is accessible only for maintenance and repair.

**Suspended ceiling** (fire-protecting) – a ceiling suspended below a floor, which contributes to the fire resistance of the floor.

**Thermoplastic material** – a synthetic polymeric material which can be classified in accordance with paragraph 2.4 or 2.5.

**Travel distance** – the actual distance to be travelled by a person from any point within the floor area to the nearest storey exit, having regard to the layout of walls, partitions and fittings.

**Unprotected area** – in relation to a side or external wall of a building means –

(a) a window, door or other opening;

(b) any part of the external wall which has less than the relevant fire resistance set out in Table 3.1; and

(c) any part of the external wall which has combustible material more than 1 mm thick attached or applied to its external face, whether for cladding or any other purpose.

**Wall** – (for the purposes of Section 2) includes –

(a) the surface of glazing (except glazing in doors); and

(b) any part of a ceiling which slopes at an angle of more than 70° to the horizontal, and excludes –

(i) doors and door frames;

(ii) window frames and frames in which glazing is fitted;

(iii) architraves, cover moulds, picture rails, skirtings and similar narrow members; and

(iv) fireplace surrounds, mantleshelves and fitted furniture.

# Appendix – Publications referred to

BS 476: Fire tests on building materials and structures

Part 3: 1958 External fire exposure roof test

Part 4: 1970 (1984) Non-combustibility test for materials

AMD 2483 March 1978

AMD 4390 September 1983

Part 6: 1981 Method of test for fire propagation for products

AMD 4329

Part 6: 1989 Method of test for fire propagation for products

Part 7: 1971 Surface spread of flame tests for materials

Part 7: 1987 (1993) Method for classification of the surface spread of flame of products

AMD 6249 January 1990

AMD 7030 January 1992

AMD 7612 April 1993

Part 8: 1972 Test methods and criteria for the fire resistance of elements of building construction

AMD 1873 January 1976

AMD 3816 November 1981

AMD 4822 May 1985

Part 11: 1982 (1988) Method for assessing the heat emission from building materials

Part 20: 1987 Method for determination of the fire resistance of elements of construction (general principles)

AMD 6487 April 1990

Part 21: 1987 Methods for determination of the fire resistance of loadbearing elements of construction

Part 22: 1987 Methods for determination of the fire resistance of non-loadbearing elements of construction

Part 23: 1987 Methods for determination of the contribution of components to the fire resistance of a structure

Part 24: 1987 Method for determination of the fire resistance of ventilation ducts

Section 31.1: 1983 Method of measurement under ambient temperature conditions

BS 747: 1977 (1986) Specification for roofing felts

AMD 3775 November 1981

AMD 4609 February 1985

AMD 5101 February 1986

BS 2782: Method of testing plastics

Part 1: 1976 Method 120A

Part 5: 1970 Miscellaneous methods

AMD 1524 July 1974

BS 4514: 1983 Specification for unplasticized PVC soil and ventilating pipes, fittings and accessories

AMD 4517 June 1984

AMD 5584 November 1987

BS 5255: 1989 Specification for thermoplastics waste pipe and fittings

BS 5266: Emergency lighting

Part 1: 1988 Code of practice for the emergency lighting of premises other than cinemas and certain other specified premises used for entertainment

BS 5306: Fire extinguishing installations and equipment on premises

Part 1: 1976 (1988) Hydrant systems, hose reels and foam inlets

AMD 4649 August 1984

AMD 5756 February 1988

Part 2: 1990 Specification for sprinkler systems

BS 5395: Stairs, ladders and walkways

Part 2: 1984 Code of practice for the design of helical and spiral stairs

AMD 6076 July 1989

BS 5438: 1989 Methods of test for flammability of textile fabrics when subjected to a small igniting flame applied to the face or bottom edge of vertically oriented specimens

AMD 6509 June 1990

---

BS 5446: Components of automatic fire alarm systems for residential premises

Part 1: 1990 Specification for self-contained smoke alarms and point-type smoke detectors  
AMD 6863 September 1991  
AMD 7648 May 1993

BS 5499: Fire safety signs, notices and graphic symbols

Part 1: 1990 Specification for fire safety signs  
AMD 7444 January 1993

BS 5588: Fire precautions in the design, construction and use of buildings

Part 4: 1978 Code of practice for smoke control in protected escape routes using pressurization  
AMD 5377 September 1986

Part 5: 1991 Code of practice for firefighting stairs and lifts  
AMD 7196 June 1992

Part 6: 1991 Code of practice for places of assembly

Part 8: 1988 Code of practice for means of escape for disabled people

Part 9: 1989 Code of practice for ventilation and air conditioning ductwork

Part 10: 1991 Code of practice for shopping complexes

BS 5839: Fire detection and alarm systems for buildings

Part 1: 1988 Code of practice for system design, installation and servicing  
AMD 6317 January 1991  
AMD 6874 May 1992

BS 5867: Specification for fabrics for curtains and drapes

Part 2: 1980 (1993) Flammability requirements  
AMD 4319 July 1983

BS 6073: Precast concrete masonry units

Part 1: 1981 Specification for precast concrete masonry units  
AMD 3944 March 1982  
AMD 4462 February 1984

BS 6387: 1994 Specification for performance requirements for cables required to maintain circuit integrity under fire conditions

CP 144: Roof coverings

Part 3: 1970 Built-up bitumen felt. Metric units  
AMD 2527 April 1978  
AMD 5229 June 1986

CP 1007: 1955 Maintained lighting for cinemas

BR 128: 1988 Guidelines for the construction of fire-resisting structural elements

BR 135: 1988 Fire performance of external thermal insulation for walls of multi-storey buildings

BR 187: 1991 External fire spread: building separation and boundary distances

Fire Services (Northern Ireland) Order 1984 as amended 1993

The Steel Construction Institute 1990: Fire and steel construction: The Behaviour of Steel Portal Frames in Boundary Conditions (2nd Edition)